

# F300 megablock range

## MTL fieldbus device couplers





# EC Declaration of Conformity

## F30X Megablock Device Couplers

Document No. MTL15DOCF30X

Issue No. 2

We declare under our sole responsibility that the product(s) listed below, to which this declaration relates, conform with the requirements of the Directives below by compliance with the standards listed.

**EMC Directive - Council Directive 2004/108/EC to 19 April 2016 and 2014/30/EU from 20 April 2016** relating to Electromagnetic Compatibility.

- a. EN 61326-1:2013 Class A equipment. Table 2 – Industrial locations

**Low Voltage Directive - Council Directive 2006/95/EC to 19 April 2016 and 2014/35/EU from 20 April 2016** relating to Product Safety.

- b. EN 61010-1:2010

Compliance with the Low Voltage Directive (LVD) is not required for products covered by the ATEX Directive, however it is included in this declaration as the LVD may apply to these products if they are used in situations not covered by the ATEX Directive.

**ATEX Directive - Council Directive 94/9/EC to 19 April 2016 and 2014/34/EU from 20 April 2016** relating to equipment and protective systems intended for use in potentially explosive atmospheres.

- c. EN 60079-0:2012+A11:2013<sup>†</sup>  
d. EN 60079-15:2010<sup>†</sup>

<sup>†</sup> Where products were initially assessed for compliance with the Essential Health and Safety Requirements of the Directive using earlier harmonised standards, a subsequent review has determined that compliance is unaffected by the current harmonised standard(s) listed above.

  
Stewart Parfitt  
Engineering Director  
29 January 2016

**Measurement Technology Limited**  
Luton, Bedfordshire, UK, LU2 8DL  
Telephone +44 1582 723633  
Fax +44 1582 422283  
Email [mtlenquiry@eaton.com](mailto:mtlenquiry@eaton.com)  
Website [www.mtl-inst.com](http://www.mtl-inst.com)

**Products covered by this declaration:**

Product	Description	EMC <sup>1</sup> Standards	LVD <sup>1</sup> Standards	Year LVD Applied	ATEX <sup>1</sup> Standards	ATEX <sup>2</sup> Marking	R&TTE <sup>1</sup> Standards	Cat1/Cat2 ATEX Cert. No.	Cat3 ATEX Cert. No.
F97	Overmoulded Terminator	a	See Note 4	2015	c, d	3	N/A	None	None <sup>5</sup>
F304-PC	4-port Megablock with screw terminals with F97 terminator	a	See Note 4	2015	c, d	3	N/A	None	REL C11ATEX1010X
F308-PC	8-port Megablock with screw terminals with F97 terminator	a	See Note 4	2015	c, d	3	N/A	None	REL C11ATEX1010X
F312-PC	12-port Megablock with screw terminals with F97 terminator	a	See Note 4	2015	c, d	3	N/A	None	REL C11ATEX1010X

**Notes:**

- 1 Entries in this column may be either letter notation (a,b,c etc..) indicating which standards from page 1 apply, or N/A if the directive does not apply
- 2 Entries in this column refer to notes below indicating ATEX markings present on products, or N/A if the directive does not apply
- 3 ATEX marking  II 3 GD Ex nA[Ic] IIC T4 Gc -40°C ≤ Ta ≤ +70°C
- 4 Products comply with the LVD because they do not provide voltage isolation and the maximum input voltage is below 75Vdc.
- 5 The F97 is an accessory for the F30X products. It is certified as part of the F3XX certification, however it is not marked to be a stand-alone certified product.

THIS PAGE IS LEFT INTENTIONALLY BLANK

# CONTENTS

<b>1</b>	<b>OVERVIEW</b> .....	<b>1</b>
<b>2</b>	<b>DESCRIPTION</b> .....	<b>1</b>
<b>3</b>	<b>COMPONENTS AND ACCESSORIES</b> .....	<b>2</b>
<b>4</b>	<b>MECHANICAL</b> .....	<b>2</b>
4.1	Mounting orientation .....	2
4.2	Enclosure requirements .....	2
4.3	DIN-rail mounting .....	3
4.4	Removal from DIN-rail .....	3
<b>5</b>	<b>ELECTRICAL CONNECTIONS</b> .....	<b>3</b>
5.1	DC Power Requirements .....	4
5.2	Terminator .....	4
5.3	Trunk connections .....	4
5.4	Spur port connections .....	5
5.5	Cable screen connections .....	5
5.6	Surge protection .....	5
<b>6</b>	<b>TESTING</b> .....	<b>6</b>
6.1	Power LED .....	6
6.2	Spur LEDs .....	6
<b>7</b>	<b>ROUTINE MAINTENANCE</b> .....	<b>6</b>
<b>8</b>	<b>ATEX SAFETY INSTRUCTIONS</b> .....	<b>7</b>
8.1	General .....	7
8.2	Installation .....	7
8.3	Inspection and maintenance .....	7
8.4	Repair .....	7
8.5	Marking .....	8
<b>9</b>	<b>FM CONTROL DRAWINGS</b> .....	<b>9</b>
<b>10</b>	<b>IECEX SAFETY INSTRUCTIONS</b> .....	<b>11</b>
10.1	Conditions of safe use .....	11
10.2	IECEX Control drawings .....	12/13/14

## GENERAL SAFETY INFORMATION

The following methods are used in this manual to alert the user to important information:-



**WARNING !**  
Warnings are provided to ensure operator safety and **MUST** be followed.

### CAUTION

Cautions are provided to prevent damage to the instrument.

### NOTE

These are used to give general information to ensure correct operation.

## SAFETY INSTRUCTIONS FOR INSTALLATION AND OPERATING PERSONNEL

The operating instructions provided here contain **essential safety instructions** for installation personnel and those engaged in the operation, maintenance and servicing of the equipment.



**WARNING !**  
Failure to comply with these instructions can endanger the lives or health of personnel and risk damage to the plant and the environment.



**WARNING !**  
The responsibility for planning, installation, commissioning, operation and maintenance, particularly with respect to applications in explosion-hazard areas, lies with the plant operator.

### Before commencing installation or commissioning:

- Read and understand the contents of this manual and the product datasheet
- Ensure installation and operating personnel have received adequate training for this task
- Ensure that any operating instructions are fully understood by the personnel responsible.
- Observe national and local installation and mounting regulations (e.g. IEC 60079-14).



**WARNING !**  
If these assemblies have been used previously in general electrical installations, they **MAY NOT** be used in explosion-hazard area applications.

### During operation:

- Make the relevant instructions available at all times to the operating personnel.
- Observe safety instructions.
- Observe national safety and accident prevention regulations.
- Operate the equipment within its published specification.
- Servicing, maintenance work or repairs not described in this manual must not be performed without prior agreement with the manufacturer.
- Any damage to this equipment may render its explosion protection null and void.
- No changes to any of the components that might impair their explosion protection are permitted.

### If any information provided here is not clear:

- Contact Eaton's MTL product line or one of its representatives.

### NOTE

Improper installation and operation of the enclosure can result in the invalidation of the guarantee.

## F300 megablock range MTL Fieldbus device couplers



**Figure 1.1** - Megablock models F312, F308 and F304

### 1 OVERVIEW

F300 Megablocks are DIN-rail mounted, device couplers for FOUNDATION™ fieldbus or Profibus PA networks. They allow connection of field devices to the segment trunk cable and provide short-circuit protection to the segment.

Megablocks minimize hand wiring and allow individual devices to be added to and removed from the segment without disrupting network communication.

Megablocks are available in four, eight, and twelve port versions. Multiple Megablocks are easily wired together to allow larger segments to be constructed.

Each F300 Megablock includes an F97 Terminator for installation in the trunk terminals, which is clearly marked with a large 'T' for easy identification by field personnel.

Individual surge-protector modules (FS32) can also be fitted to any of the Megablock fieldbus terminals to provide protection against induced surges and transients that can potentially destroy or degrade certain components inside the F300 Megablocks.

### 2 DESCRIPTION

#### Simple and reliable interconnection

Each Megablock has dedicated connections for the fieldbus “home run” or trunk cable. Trunk connections are identified by their black connectors. Numbered (grey) connectors are provided for each spur.

Wiring connections to the Megablock are made using pluggable connectors (screw terminal type are standard, but other connection styles are available). These allow wire terminations to be made to the individual connectors, which are then plugged into the Megablock. Devices can be connected and disconnected easily during commissioning. On completion, the connector retaining screws are tightened to secure each connector to the Megablock.



### Short-circuit protection

To minimize susceptibility to single points of failure, F300 Megablocks are provided with built-in SpurGuard™ short-circuit protectors, which prevent the entire Fieldbus segment from being pulled down in the event of a short circuit on any one of the individual field devices or spur cable runs.

#### NOTE

During a short circuit, the shorted spur draws more current than a normal Fieldbus device - this must be taken into account in segment design.

### Diagnostic aids

Each Megablock comes with a green LED to indicate whether DC Power is present, and a red LED next to each numbered spur indicates when the spur is in short circuit.

## 3 COMPONENTS AND ACCESSORIES

Product part numbers and their descriptions are listed below.

Part Number	Description
F304[-PC]*	4-way Megablock
F308[-PC]*	8-way Megablock
F312[-PC]*	12-way Megablock
F97	Terminator for F300 series Megablocks
F300-A01-5	Trunk-spur partition – pack of 5
FS32	Spur surge protector module
F300-BAR-5	FS32 grounding bars for trunk - pack of 5
F304-BAR-10	FS32 grounding bars for F304 - pack of 10 †
F308-BAR-10	FS32 grounding bars for F308 - pack of 10 †
F312-BAR-10	FS32 grounding bars for F312 - pack of 10 †

\* The standard connector for the Megablock is a pluggable screw terminal (elevator type). Pluggable spring-clamp connectors rely on constant spring pressure to maintain contact with the wire. To order Megablocks with pluggable spring-clamp connectors, add a -PC suffix to the part number (i.e. F304-PC).

† Up to two bars may be required for each Megablock.

## 4 MECHANICAL

### 4.1 Mounting orientation

Megablocks mount vertically or horizontally on 35mm DIN rail within a field junction box. The use of DIN rail end stops are recommended to prevent sliding (especially for vertical installations).

Eight, and twelve port Megablocks have areas on their body for labelling so that segments can be easily identified according to plant standards.

### 4.2 Enclosure requirements

#### 4.2.1 General requirements

Megablocks may be mounted in hazardous (classified) areas – see section 8. The following conditions must also be satisfied to ensure safe and reliable operation.

- Prevent any form of pollution that could compromise the operation of the unit. For example, choose an unpolluted location or a suitable enclosure to protect the assembly.
- Provide an adequate level of mechanical protection. This can be achieved by selecting a protected location, a suitable enclosure, or a combination of both.
- Ensure that all cable entries and connections are secure by making provision for



the careful routing and securing of all cables.

- d) Provide adequate security against unauthorized interference.
- e) Conform to the permitted ambient temperature range of  $-40^{\circ}\text{C}$  to  $+70^{\circ}\text{C}$ .

#### 4.2.2 Outdoor mounting

In addition to the General Requirements above, if the Megablock is mounted in an outdoor location, use a suitable enclosure with a minimum of IP54 ingress protection. A higher level of ingress protection rating will be necessary if the working atmosphere is, or can be, corrosive, or if the enclosure is subject to wet or dusty environments.

#### 4.3 DIN-rail mounting

The Megablocks are designed for mounting on 35mm x 7.5mm T-section "top hat" DIN rail to EN50022 and use built-in DIN rail clips to attach to the rail.

##### 4.3.1 Mounting procedure

Megablocks are attached to the DIN rail using a "push-and-tilt" method- as illustrated on the body label and in Figure 4.1 below.

Tilt the Megablock towards the trunk-connector side of the Megablock and then engage the DIN-rail clips under the ledge of the DIN rail. Push the Megablock against the edge of the rail then rotate the Megablock until it sits flat onto the DIN rail, then release the pressure to allow the clips on the other side to engage.

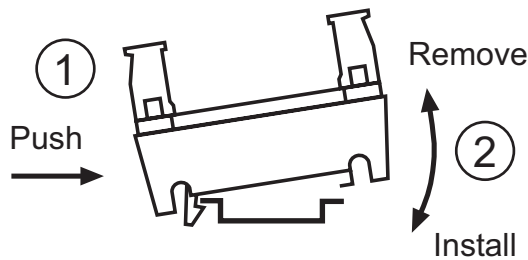

**Figure 4.1: DIN Rail Installation and Removal**

#### 4.4 Removal from DIN-rail

Referring to Figure 4.1, push the Megablock against the edge of the DIN rail, tilt the other side of the Megablock up and away from the DIN rail, then release the side pressure to disengage the DIN rail clips from the DIN rail ledge.

### 5 ELECTRICAL CONNECTIONS

The Trunk and Spur connectors are pluggable (with securing screws) and available in the standard screw-terminal version or a spring-clamp version. Megablocks with spring clamp connectors have a -PC suffix on the Megablock part number (-PC). See Figures 5.1 and 5.2. The terminals can accept the following conductor sizes:

Type	Conductor size
Screw terminals	0.14 to 2.5mm <sup>2</sup>
Spring clamp terminals (-PC)	0.20 to 2.5mm <sup>2</sup>

#### NOTE

A torque screwdriver set between 0.5 - 0.6Nm is recommended for tightening all terminal screws.

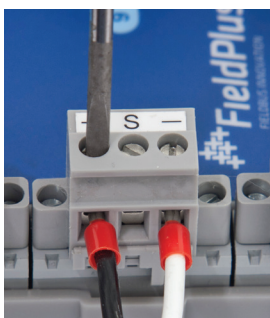

**Figure 5.1: Screw Terminal**

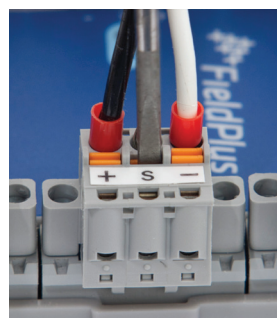

**Figure 5.2: Spring Clamp**

**NOTE**

When wiring to spring-clamp terminals, use a screwdriver with a 3-4 mm blade to depress the spring-clamp button before inserting the termination cable. See Figure 5.2.

**5.1 DC Power Requirements**

Megablocks draw DC power from the fieldbus trunk segment they are connected to. The minimum DC input voltage, and current required, vary with the Megablock type. Refer to the F300 datasheet for exact current requirements. The maximum input voltage is 32V DC, but a lower voltage may be required in order to achieve safety in some hazardous area applications- refer to the Control Drawings in Sections 9 & 10 of this manual.

**5.2 Terminator**

A terminator (Model No. F97) is provided with each F300 Megablock. The terminator should be installed on the trunk of the last Megablock in order to correctly terminate the bus. The terminator is placed in the second set of terminals on the trunk connector.

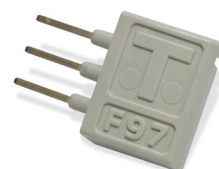

**Figure 5.3  
F97 terminator**

For spring clamp terminals, push the terminator firmly into place. **Take care** to orientate the terminator so that the “T-F97” molded logo is facing *inwards* towards the body of the Megablock, otherwise difficulty will be experienced in accessing the spring-clamp buttons to remove it. For screw terminals, loosen the screws, insert the terminator so that the molded logo is visible and then tighten the screws. The F97 terminator has no specific polarity but inserting it with the ‘T’ visible clearly identifies the component, and its purpose.

When not in use, the F97 should be stored in the convenient storage slot provided in the F300 body close to the trunk connection (Figure 1.1 shows it mounted this way on the F304 model).

**5.3 Trunk connections**

Each trunk connector provides two sets of interlinked (+), (-) and cable screen (S) connections.

The second connection enables the user to onward connect the trunk to a further Megablock and avoids breaking the connection if an “upstream” Megablock needs to be removed.

The second connection can also be used, as mentioned above, to install the F97 terminator if it is the last Megablock on the segment. See Section 5.5 for information on cable screen grounding.



**WARNING !**

It is not permitted to connect or disconnect the trunk wiring in a hazardous area without a gas clearance certificate or unless the circuit to which it is connected has been de-energised.

### 5.3.1 Ex nA [ic] applications

When the equipment is installed in an Ex nA [ic] application, a trunk-spur partition\* must be installed to segregate the trunk and spur wiring- see Figures 5.4 and 5.5.

\* available in packs of five as Part No. F300-A01-5

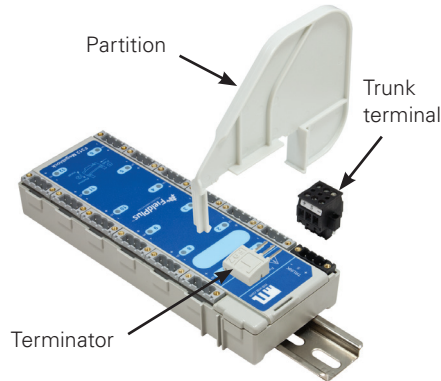

**Figure 5.4:** Trunk-Spur partition installation



**Figure 5.5:** Trunk-Spur partition in position

Position the partition as shown in Figure 5.4 and locate the fingers into the channels on the sides of the device body. Press the partition onto the body until the fingers click into place at the bottom of the case- see Figure 5.5. The channels have different sizes so the partition cannot be installed backwards.

### 5.4 Spur port connections

Each spur port connector provides (+), (-) and cable screen (S) connections. See section 5.5 for information on cable screen grounding.

#### Cable screen connections

The 'S' screen terminals for the trunk and the spurs are interconnected/commoned within the F3xx device and should be grounded at only *one point* for the whole segment (i.e. a single-point ground). The recommended position for that connection is in the control room close to the power supply at the DCS, or else in accordance with local system practice.

### 5.5 Surge protection

Each fieldbus terminal, trunk or spur, on a Megablock can be fitted with an FS32 surge protector to prevent damage to the internal components. The FS32 uses the same pluggable connector as the field connector; so the field connector is removed, the FS32 inserted and the original field connector is fitted to the FS32. See Figure 5.6 & 5.7.

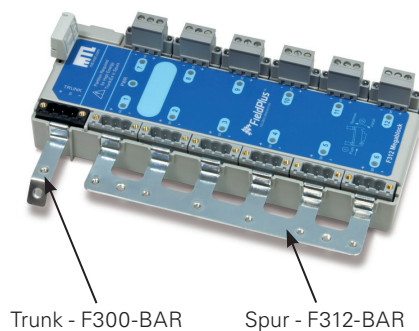

**Figure 5.6:** Typical grounding bars

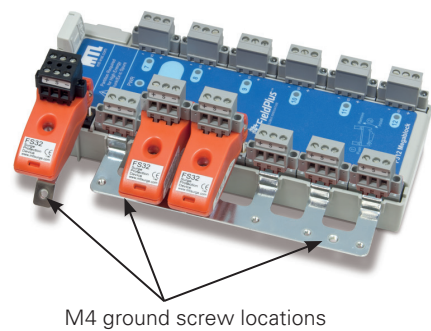

**Figure 5.7:** With some FS32 modules

Mounting brackets, known as "grounding bars", can be fitted into ready moulded

positions on both sides of the Megablock. (Grounding bar types are chosen to suit the model- see page 2.) The FS32 has a central mounting screw to provide a mechanical and electrical connection to the grounding bar. The bar must then be wired to a low-impedance, protective local ground point in order to dissipate any induced surge currents.

**NOTE**

If a trunk-spur partition is to be fitted (Section 5.3.1), install it **before** mounting the FS32 modules adjacent to it.

To mount FS32 surge protection modules on a Megablock:

1. Remove and retain the pluggable terminals from one side of the Megablock.
2. Locate the grounding bar lugs in the moulded positions on the side of the Megablock and press it firmly into place- see Figure 5.6.
3. Repeat 1 and 2 for the other side of the Megablock, if required.
4. Use an M4 screw and ring terminal to connect *each* grounding bar to a suitable low-impedance ground point- see Figure 5.7.
5. Mount an FS32 into one of the empty sockets and tighten its two plug screws, then tighten the grounding screw into the mounting bar.
6. Insert one of the pluggable terminals into the FS32 and tighten its securing screws.
7. Repeat 5 and 6 for all the other FS32 modules.

A separate grounding bar (F300-BAR) is used for the trunk connector, which must be similarly connected to ground- see Figures 5.6 & 5.7 Follow a similar procedure to the one above for the trunk circuit.

**NOTE**

The FS32 surge protector is not certified for installation in a Zone 2 hazardous area and should be used only in applications where the Megablock is installed in a safe (non-hazardous) area. Consult Eaton's MTL product line for information on surge protection in Zone 2 hazardous areas.

## 6 TESTING

### 6.1 Power LED

Each Megablock has a green power LED (labelled PWR). This LED lights when the segment DC voltage exceeds 10V to indicate power is present.

### 6.2 Spur LEDs

A red LED is located next to each Megablock spur port. The LED lights when the SpurGuard™ current-limiting function is activated by a short-circuit on the spur.

## 7 ROUTINE MAINTENANCE

Check the general condition of the installation periodically to make sure that no deterioration has occurred. At least every two years (and more frequently for particularly harsh environments) check that:

- cable, wire connections, terminations, and screens are in good condition
- the green Power LED is lit
- no red spur LEDs are lit
- no signs of damage or corrosion are present



**WARNING !**

The plastic parts can store static charge. Clean only with a damp cloth to prevent static buildup.

## **8 ATEX SAFETY INSTRUCTIONS**

The following information is in accordance with the Essential Health and Safety Requirements (Annex II) of the EU Directive 94/9/EC [the ATEX Directive- safety of apparatus] and is provided for those locations where the ATEX Directive is applicable.

### **8.1 General**

- a) This equipment must only be installed, operated and maintained by competent personnel. Such personnel shall have undergone training, which included instruction on the various types of protection and installation practices, the relevant rules and regulations, and on the general principles of area classification. Appropriate refresher training shall be given on a regular basis. [See clause 4.2 of EN 60079-17].
- b) This equipment has been designed to provide protection against all the relevant additional hazards referred to in Annex II of the directive, such as those in clause 1.2.7.
- c) This equipment has been designed to meet the requirements of EN 60079-15.

### **8.2 Installation**

- a) The installation must comply with the appropriate European, national and local regulations, which may include reference to the code of practice EN 60079-14. In addition, particular industries or end users may have specific requirements relating to the safety of their installations and these requirements should also be met. For the majority of installations the Directive 1999/92/EC [the ATEX Directive- safety of installations] is also applicable.
- b) This apparatus may be installed in a safe area and also in a Zone 2 location providing that the relevant installation conditions are met. When mounted in a Zone 2 location the apparatus must be provided with an enclosure, which offers an additional degree of protection appropriate to the area classification.
- c) Unless already protected by design, this equipment must be protected by a suitable enclosure against:
  - i) mechanical and thermal stresses in excess of those noted in the certification documentation and the product specification
  - ii) aggressive substances, excessive dust, moisture and other contaminants.

Read also the Special Conditions for Safe Use (below) for any additional or more specific information.

#### **Special Conditions of Safe Use for Zone 2 applications**

The apparatus is to be installed in an enclosure which maintains a minimum ingress protection rating of IP54 and meets the enclosure requirements of EN 60079-0, EN 60079-11, and EN 60079-15 as appropriate for the installation. Provisions shall be made externally to the apparatus to prevent the rated input being exceeded by transient disturbances of more than 140% of the rated voltage. *See footnote.*

### **8.3 Inspection and maintenance**

- a) Inspection and maintenance should be carried out in accordance with European, national and local regulations which may refer to the standard EN 60079-17. In addition specific industries or end users may have specific requirements which should also be met.
- b) Access to the internal circuitry must not be made during operation.

### **8.4 Repair**

This product cannot be repaired by the user and must be replaced with an equivalent certified product.

*(continued on following page)*

*NOTE: All MTL fieldbus power supplies are designed to protect the fieldbus trunk from transient disturbances on the DC power feed and will meet the requirements of maintaining transient disturbances below 140% of the rated voltage.*

## 8.5 Marking

Each device is marked in compliance with the Directive.

This information applies to products manufactured during or after the year 2011.

### Typical certification marking

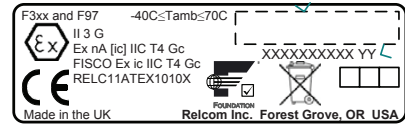
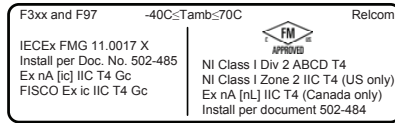

#### NOTE

For details of FM and IECEx approvals see Sections 9 & 10.

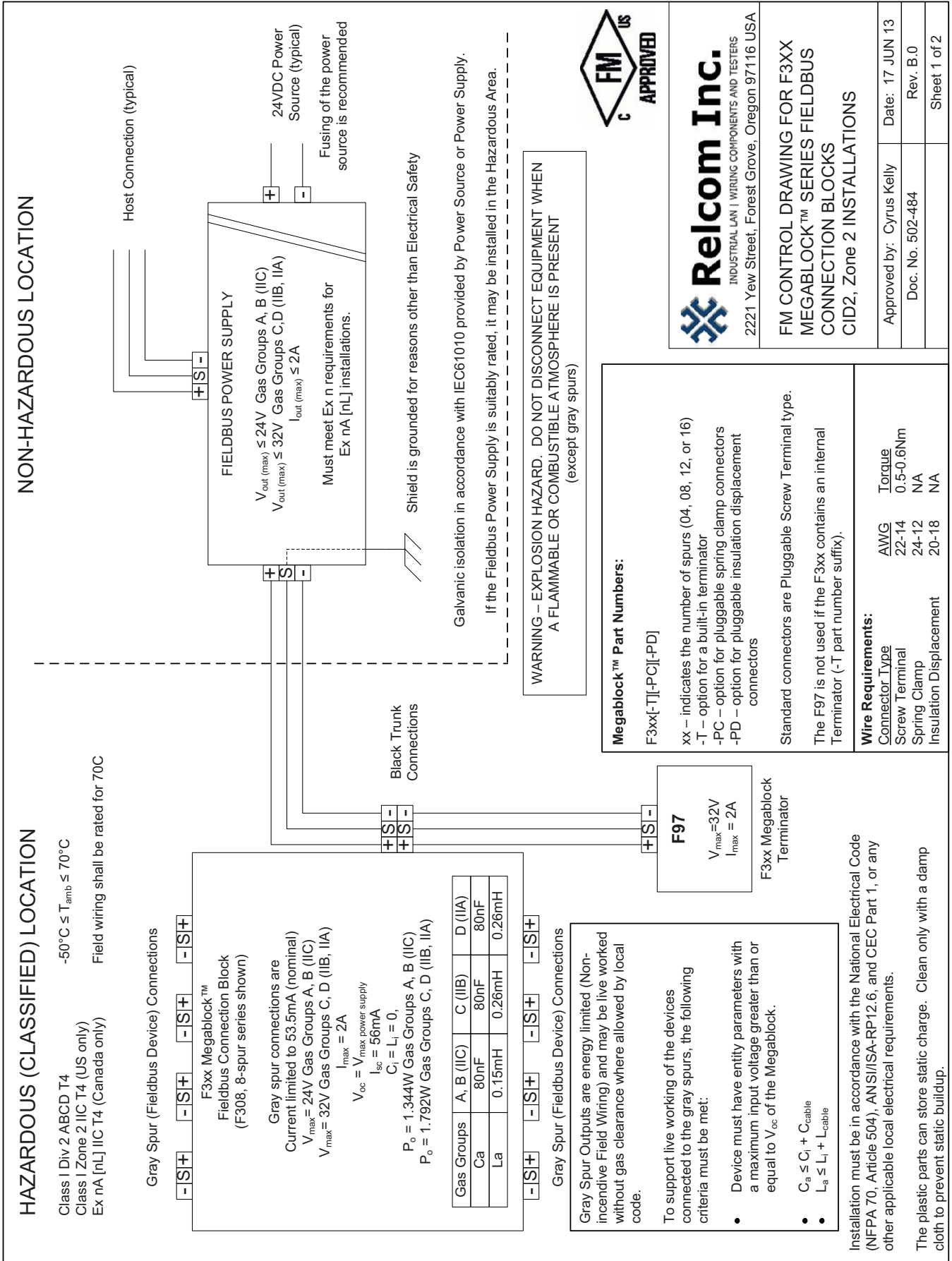



### Installing the Partition, Terminator, and Connector

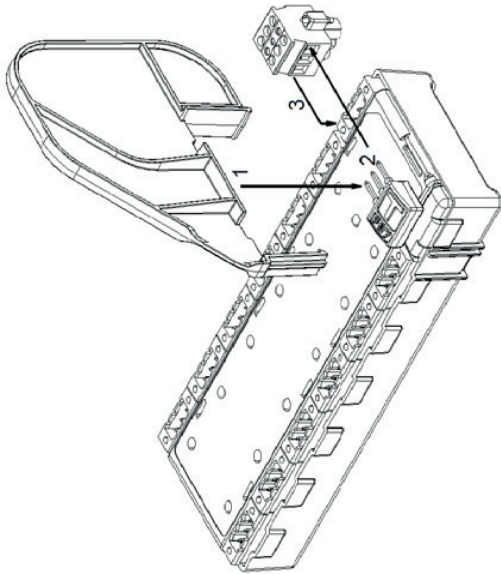

### Partition, Terminator, and Connector Installed

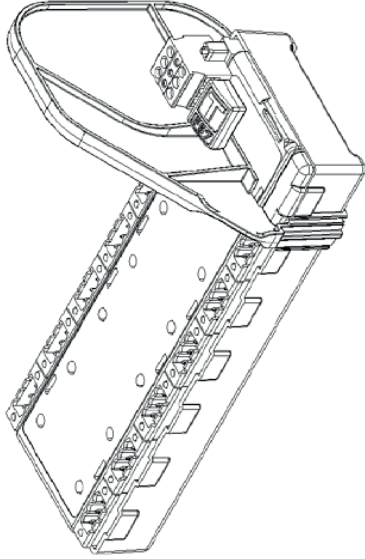

#### Partition Installation

The Partition must be installed for Ex nA [ic] applications. Orient the partition as shown above and press down as indicated by the arrow. The 'fingers' will slide in the two channels on each side of the F3xx until they latch in place at the bottom of the case. The channels are sized differently so the Partition cannot be installed backwards.

#### Terminator Installation

If needed the F97 Terminator is installed in the Black Dual Pluggable connector as shown above. Insert it into the connector and tighten the screws.

#### Connector Installation

The connectors are installed as shown in the diagram above. Fully insert them into the mating connector on the F3xx. Secure the two retaining screws to prevent the connector from unexpectedly dislodging.

#### DIN Rail Mounting

F3xx Megablocks are designed to be mounted on 35 mm DIN rail using the clip mechanism on the back of each unit. Mounting can be vertical or horizontal. Use of DIN rail end stops is recommended.

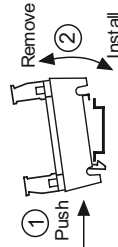

#### Repair and Maintenance

No regular maintenance is required for these products. There are also no user serviceable parts in this product. Contact the distributor or factory for any product issues.

#### Special Conditions of Safe Use

- The apparatus shall be installed in an enclosure which maintains an ingress protection rating of IP54 and meets the enclosure requirements of E60079-0 and E60079-15.
- The apparatus shall be installed in an enclosure meeting the requirements of ANSI/ISA 61010-1 (82.02.01) and CSA Standard C22.2 No 61010-1.
- The apparatus shall be installed in compliance with the enclosure, mounting, spacing and segregation requirements of the ultimate application.
- Provisions shall be made externally to the F3XX to prevent the rated input being exceeded by transient disturbances of more than 140% of the rated voltage.

#### Certification Markings

 NI Class I Div 2 ABCD T4  
NI Class I Zone 2 IIC T4 (US only)  
Ex nA [nL] IIC T4 (Canada only)  
Install per document 502-484  
Relcom Inc. Forest Grove, OR USA

 **Relcom Inc.**  
INDUSTRIAL LAN | WIRING COMPONENTS AND TESTERS  
2221 Yew Street, Forest Grove, Oregon 97116 USA

F3XX MEGABLOCK™ SERIES

INSTALLATION INSTRUCTIONS

Approved by: Cyrus Kelly Date: 17 JUN 13  
Doc. No. 502-484 Rev. B.0

Sheet 2 of 2



## 10 IECEX SAFETY INSTRUCTIONS

### 10.1 Conditions of safe use

#### **Ex nA [ic] IIC T4 Gc**

1. The apparatus is to be installed in an enclosure which maintains a minimum ingress protection rating of IP54 and meets the enclosure requirements of IEC 60079-0, IEC 60079-11 and IEC 60079-15.
2. Provisions shall be made externally to the apparatus to prevent the rated input being exceeded by transient disturbances of more than 140% of the rated voltage.

*See footnote.*

#### **Ex ic IIC T4 Gc FISCO**

1. The apparatus is to be installed in an enclosure which maintains a minimum ingress protection rating of IP54 and meets the enclosure requirements of IEC 60079-0 and IEC 60079-11.

*Note: All MTL fieldbus power supplies are designed to protect the fieldbus trunk from transient disturbances on the DC power feed and will meet the requirements of maintaining transient disturbances below 140% of the rated voltage.*

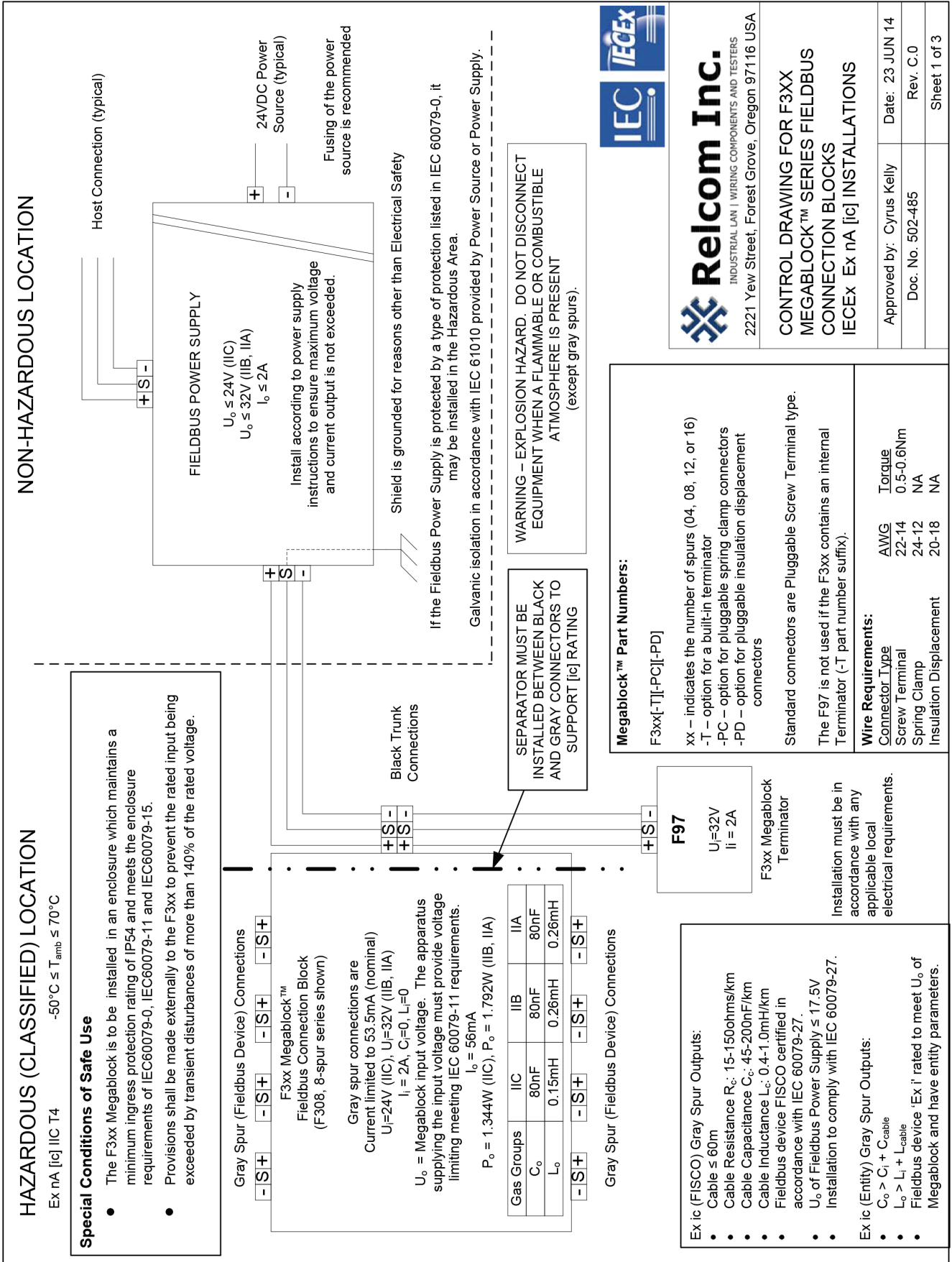

## HAZARDOUS (CLASSIFIED) LOCATION

Ex: ic IIC T4 Gc FISCO  $-50^{\circ}\text{C} \leq T_{\text{amb}} \leq 70^{\circ}\text{C}$

### Special Conditions of Safe Use

- The F3xx Megablock is to be installed in an enclosure which maintains a minimum ingress protection rating of IP54 and meets the enclosure requirements of IEC60079-0 and IEC60079-11

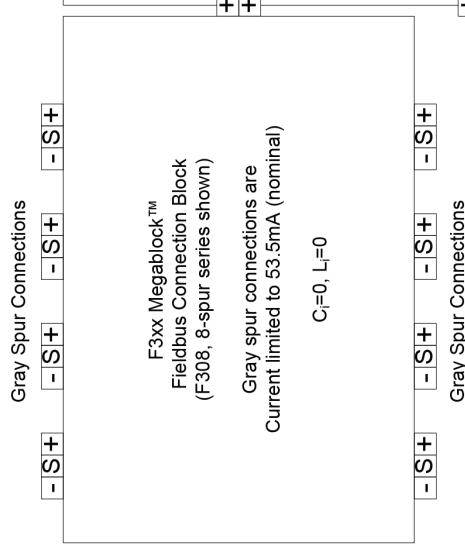

Warning: The plastic parts can store static charge. Clean only with a damp cloth to prevent static buildup.

FISCO ic (FNICO) Installation Requirements	
Device Capacitance:	0 – 5nF
Device Inductance:	0 – 10µH
Cable resistance, R <sub>c</sub> :	15 – 150 ohms/km
Cable inductance, L <sub>c</sub> :	0.4 – 1.0 mH/km
Cable capacitance, C <sub>c</sub> :	45-200nF/km
Max. Segment length:	1 km for IIC; 5 km for IIB (Note 1)
Maximum Spur length:	60m
Installation to comply with IEC 60079-27	

Note 1: Limited to 1.9 km by IEC61156-2.

## NON-HAZARDOUS LOCATION

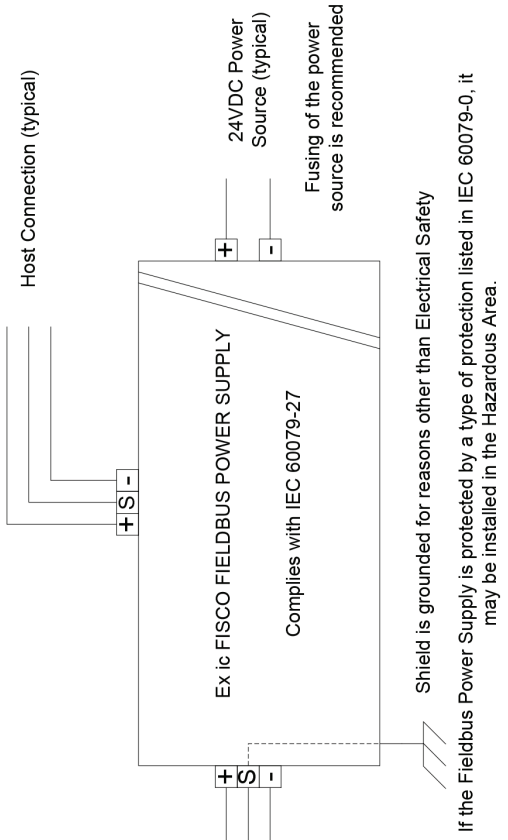

Installation must be in accordance with any applicable local electrical requirements.

### Megablock™ Part Numbers:

F3xx[-T]-[PC]-[PD]

- xx – indicates the number of spurs (04, 08, 12, or 16)
- T – option for a built-in terminator
- PC – option for pluggable spring clamp connectors
- PD – option for pluggable insulation displacement connectors

Standard connectors are Pluggable Screw Terminal type.

The F97 is not used if the F3xx contains an internal Terminator (-T part number suffix).

### Wire Requirements:

Connector Type	AWG	Torque
Screw Terminal	22-14	0.5-0.6Nm
Spring Clamp	24-12	NA
Insulation Displacement	20-18	NA



**Relcom Inc.**

INDUSTRIAL LAN | WIRING COMPONENTS AND TESTERS  
2221 Yew Street, Forest Grove, Oregon 97116 USA

CONTROL DRAWING FOR F3XX  
MEGABLOCK™ SERIES FIELDBUS  
CONNECTION BLOCKS  
IECEx Ex ic INSTALLATIONS

Approved by: Cyrus Kelly	Date: 23 JUN 14
Doc. No. 502-485	Rev. C.0
Sheet 2 of 3	

**Installing the Partition, Terminator, and Connector**

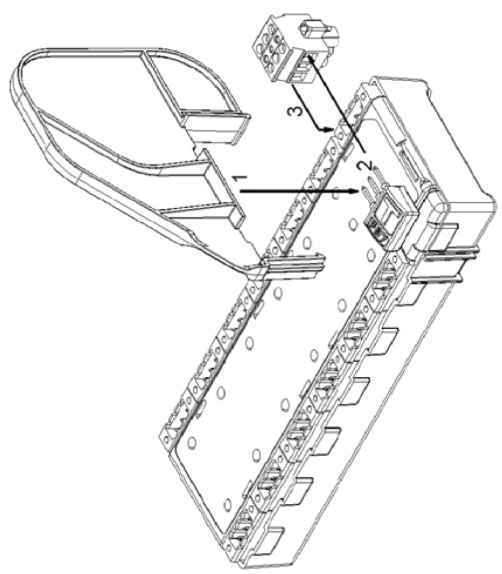

**Partition, Terminator, and Connector Installed**

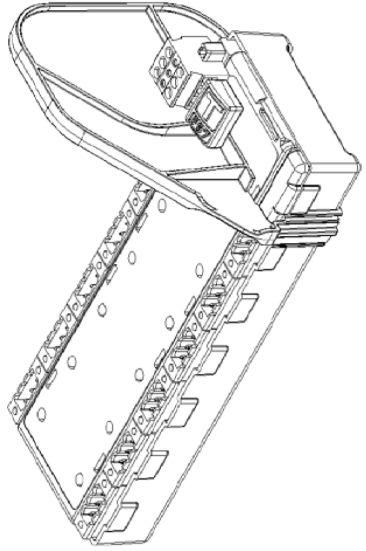

**Partition Installation**

The Partition must be installed for Ex nA [ic] applications. Orient the partition as shown above and press down as indicated by the arrow. The 'fingers' will slide in the two channels on each side of the F3xx until they latch in place at the bottom of the case. The channels are sized differently so the Partition cannot be installed backwards.

**Terminator Installation**

If needed the F97 Terminator is installed in the Black Dual Pluggable connector as shown above. Insert it into the connector and tighten the screws.

**Connector Installation**

The connectors are installed as shown in the diagram above. Fully insert them into the mating connector on the F3xx. Secure the two retaining screws to prevent the connector from unexpectedly dislodging.

**DIN Rail Mounting**

F3xx Megablocks are designed to be mounted on 35 mm DIN rail using the clip mechanism on the back of each unit. Mounting can be vertical or horizontal. Use of DIN rail end stops is recommended.

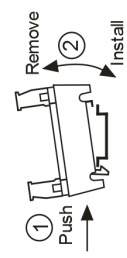

**Certification Markings**

F3xx and F97 IECEx FMG 11.0017 X  
 Install per Doc. No. 502-485  
 Ex nA [ic] IIC T4 Gc  
 Ex ic IIC T4 Gc FISCO  
 -50C-<Tamb<70C

**Repair and Maintenance**

No maintenance is required for these products. There are also no user serviceable parts in these products. Contact the distributor or factory for any product issues.



**Relcom Inc.**  
 INDUSTRIAL LAN | WIRING COMPONENTS AND TESTERS

2221 Yew Street, Forest Grove, Oregon 97116 USA

F3XX MEGABLOCK™ SERIES

INSTALLATION INSTRUCTIONS

Approved by: Cyrus Kelly	Date: 23 JUN 14
Doc. No. 502-485	Rev. C.0
	Sheet 3 of 3

THIS PAGE IS LEFT INTENTIONALLY BLANK

THIS PAGE IS LEFT INTENTIONALLY BLANK



THIS PAGE IS LEFT INTENTIONALLY BLANK

**AUSTRALIA**

MTL Instruments Pty Ltd,  
10 Kent Road, Mascot, New South Wales, 2020, Australia  
Tel: +61 1300 308 374 Fax: +61 1300 308 463  
E-mail: mtl-salesanz@eaton.com

**BeNeLux**

MTL Instruments BV  
Terheijdensweg 465, 4825 BK Breda  
The Netherlands

Tel: +31 (0) 76 7505360 Fax: +31 (0) 76 7505370  
E-mail: mtl.benelux@eaton.com

**CHINA**

Cooper Electric (Shanghai) Co. Ltd  
955 Shengli Road, Heqing Industrial Park  
Pudong New Area, Shanghai 201201

Tel: +86 21 2899 3817 Fax: +86 21 2899 3992  
E-mail: mtl-cn@eaton.com

**FRANCE**

MTL Instruments sarl,  
7 rue des Rosieristes, 69410 Champagne au Mont d'Or  
France

Tel: +33 (0)4 37 46 16 53 Fax: +33 (0)4 37 46 17 20  
E-mail: mtlfrance@eaton.com

**GERMANY**

MTL Instruments GmbH,  
Heinrich-Hertz-Str. 12, 50170 Kerpen, Germany

Tel: +49 (0)22 73 98 12-0 Fax: +49 (0)22 73 98 12-2 00  
E-mail: mtlgmbh@eaton.com

**INDIA**

MTL India,  
No.36, Nehru Street, Off Old Mahabalipuram Road  
Sholinganallur, Chennai- 600 119, India

Tel: +91 (0) 44 24501660 /24501857 Fax: +91 (0) 44 24501463  
E-mail: mtlindiasales@eaton.com

**ITALY**

MTL Italia srl,  
Via San Bovio, 3, 20090 Segrate, Milano, Italy

Tel: +39 02 959501 Fax: +39 02 95950759  
E-mail: chmninfo@eaton.com

**JAPAN**

Cooper Crouse-Hinds Japan KK,  
MT Building 3F, 2-7-5 Shiba Daimon, Minato-ku,  
Tokyo, Japan 105-0012

Tel: +81 (0)3 6430 3128 Fax: +81 (0)3 6430 3129  
E-mail: mtl-jp@eaton.com

**NORWAY**

Norex AS  
Fekjan 7c, Postboks 147  
N-1378 Nesbru, Norway

Tel: +47 66 77 43 80 Fax: +47 66 84 55 33  
E-mail: info@norex.no

**RUSSIA**

Cooper Industries Russia LLC  
Elektrozavodskaya Str 33  
Building 4  
Moscow 107076, Russia

Tel: +7 (495) 981 3770 Fax: +7 (495) 981 3771  
E-mail: mtlrussia@eaton.com

**SINGAPORE**

Cooper Crouse-Hinds Pte Ltd  
No 2 Serangoon North Avenue 5, #06-01 Fu Yu Building  
Singapore 554911

Tel: +65 6 645 9888 Fax: +65 6 487 7997  
E-mail: sales.mtlsing@eaton.com

**SOUTH KOREA**

Cooper Crouse-Hinds Korea  
7F, Parkland Building 237-11 Nonhyun-dong Gangnam-gu,  
Seoul 135-546, South Korea.

Tel: +82 6380 4805 Fax: +82 6380 4839  
E-mail: mtl-korea@eaton.com

**UNITED ARAB EMIRATES**

Cooper Industries/Eaton Corporation  
Office 205/206, 2nd Floor SJ Towers, off. Old Airport Road,  
Abu Dhabi, United Arab Emirates

Tel: +971 2 44 66 840 Fax: +971 2 44 66 841  
E-mail: mtlgulf@eaton.com

**UNITED KINGDOM**

Measurement Technology Limited,  
Great Marlings, Butterfield, Luton  
Beds LU2 8DL

Tel: +44 (0)1582 723633 Fax: +44 (0)1582 422283  
E-mail: mtlenquiry@eaton.com

**AMERICAS**

Cooper Crouse-Hinds MTL Inc.  
3413 N. Sam Houston Parkway W.  
Suite 200, Houston TX 77086, USA

Tel: +1 281-571-8065 Fax: +1 281-571-8069  
E-mail: mtl-us-info@eaton.com