



# MTL4850 and MTL4854

## HART® Connection Systems



## DECLARATION OF CONFORMITY

We declare under our sole responsibility that the MTL4850 and MTL4854 and associated products listed below, to which this declaration relates, conform to the requirements of the Directives below by compliance with the standards listed:

1. Council Directive 2004/108/EC (EMC Directive) relating to Electro-Magnetic Compatibility. EN 61326-1:2006 Class A equipment. Table 2 - Industrial Locations
2. Council Directive 94/9/EC (ATEX Directive) relating to equipment and protective systems intended for use in potentially explosive atmospheres. EN 60079-0:2012, IEC 60079-15:2010

Where products were initially assessed for compliance with the Essential Health and Safety Requirements of the Directive using earlier harmonised standards, a subsequent review has determined that “technical knowledge” is unaffected by the current harmonised standards listed above.

<b>Product</b>	<b>Description</b>	<b>EMC<sup>1</sup></b>	<b>LVD<sup>2</sup></b>	<b>ATEX<sup>3</sup></b>	<b>Cat1/Cat2 ATEX Cert No.</b>	<b>Cat3 ATEX Cert No.</b>
<b>MTL4850</b>	HART multiplexer	Yes	N/R	Yes	None	MTL08ATEX4850X
<b>MTL4854</b>	HART multiplexer	Yes	N/R	Yes	None	MTL08ATEX4850X
<b>HMx64</b>	HART multiplexer carrier	Yes	N/R	Yes	None	MTL08ATEX4850X
<b>HTP-SC16x</b>	HART multiplexer carrier	Yes	N/R	Yes	None	MTL08ATEX4850X
<b>HCU16x</b>	HART connection unit	Yes	N/R	Yes	None	MTL08ATEX4850X

Notes relating to CE Marking:

1. Entries in this column may be:

- Yes      Product conforms to the EMC Directive
- N/R      Product is not required to conform to the EMC Directive

2. Entries in this column may be:

- Yes      Product conforms to the LVD Directive
- N/R      Product is not required to conform to the LVD Directive

3. Entries in this column may be:

- Yes      Product conforms to the ATEX Directive
- N/R      Product is not required to conform to the ATEX Directive

## GENERAL SAFETY INFORMATION

The following methods are used in this manual to alert the user to important information:-



### WARNING!

Warnings are provided to ensure operator safety and MUST be followed.

### CAUTION

Cautions are provided to prevent damage to the instrument

### NOTE

These are used to give general information to ensure correct operation

### Safety instructions for installation and operating personnel

The operating instructions provided here contain essential safety instructions for installation personnel and those engaged in the operation, maintenance and servicing of the equipment.



### WARNING!

Failure to comply with these instructions can endanger the lives or health of personnel and risk damage to the plant and the environment.



### WARNING!

The responsibility for planning, installation, commissioning, operation and maintenance, particularly with respect to applications in explosion-hazard areas, lies with the plant operator

#### Before commencing installation or commissioning:

- Read and understand the contents of this manual and the product datasheet
- Ensure installation and operating personnel have received adequate training for this task
- Ensure that any operating instructions are fully understood by the personnel responsible.
- Observe national and local installation and mounting regulations (e.g. IEC 60079-14).



### WARNING!

If these assemblies have been used previously in general electrical installations, they MAY NOT be used in explosion-hazard area applications.

#### During operation:

- Make the relevant instructions available at all times to the operating personnel.
- Observe safety instructions.
- Observe national safety and accident prevention regulations.
- Operate the equipment within its published specification.
- Servicing, maintenance work or repairs not described in this manual must not be performed without prior agreement with the manufacturer.
- Any damage to this equipment may render its explosion protection null and void.
- No changes to any of the components that might impair their explosion protection are permitted.

If any information provided here is not clear, contact MTL or one of its representatives.

### NOTE

Incorrect installation and operation of this equipment can result in invalidation of the guarantee.

THIS PAGE IS LEFT INTENTIONALLY BLANK

# CONTENTS

<b>1</b>	<b>INTRODUCTION</b> .....	<b>1</b>
<b>2</b>	<b>DESCRIPTION</b> .....	<b>1</b>
2.1	General purpose or IS? .....	3
2.2	Generic or custom? .....	3
2.3	Connection methods .....	3
<b>3</b>	<b>SAFETY INFORMATION</b> .....	<b>5</b>
3.1	Precautions - General .....	5
<b>4</b>	<b>INSTALLATION</b> .....	<b>5</b>
4.1	HTP-SC32 HART connection unit .....	5
4.2	HMP-HM64 HART interface .....	7
4.3	HCU16 HART connection unit .....	10
4.4	HCU16AO HART connection unit .....	12
4.5	MTL customised backplanes .....	14
4.6	CPH-SC16(R) and CPH-SC32(R) backplanes .....	14
4.7	Backplane mounting .....	16
4.8	Backplanes – identification and tagging .....	17
4.9	Backplane earth rails .....	17
4.10	Backplanes – connections .....	18
4.11	Cabling recommendations .....	20
4.12	RS485 connection .....	20
<b>5</b>	<b>MODULES</b> .....	<b>22</b>
5.1	MTL4850 – installation .....	22
5.2	Isolator modules (if used) .....	22
5.3	MTL4850 module .....	22
<b>6</b>	<b>FAULT FINDING AND ROUTINE MAINTENANCE</b> .....	<b>23</b>
6.1	Maintenance precautions for MTL4500 modules .....	23
6.2	Fault finding on custom backplanes .....	23
6.3	Routine maintenance .....	24
<b>7</b>	<b>SOFTWARE CONNECTIVITY</b> .....	<b>24</b>
7.1	Introduction .....	24
7.2	Communication modes .....	24
7.3	Software setup .....	25
<b>8</b>	<b>APPLICATIONS INVOLVING ZONE 2 HAZARDOUS AREAS</b> .....	<b>26</b>
8.1	General .....	26
8.2	Installation .....	26
8.3	Inspection and maintenance .....	26
8.4	Repair .....	27
8.5	Marking .....	27
<b>9</b>	<b>APPENDIX A - TYPICAL COMPATIBLE SYSTEMS</b> .....	<b>27</b>
<b>10</b>	<b>APPENDIX B - ALARM EVENT LOG</b> .....	<b>28</b>

THIS PAGE IS LEFT INTENTIONALLY BLANK

# MTL4850 and MTL4854 HART multiplexer



Figure 1.1 - MTL4850 modules mounted on HMP-HM64 carrier

## 1 INTRODUCTION

This instruction manual describes the procedures for installing, connecting, checking and maintaining the MTL4850 HART® maintenance system, which is a simple interface between smart devices in the field and HART instrument management software running on a PC.

The following sections are outlined here.

Section 2 describes the system and the solutions available

Section 3 covers some safety aspects.

Section 4 deals with the installation of carriers and mounting backplanes

Section 5 describes installing and configuring the modules

Section 6 provides information on fault finding, and maintenance

Section 7 introduces software for the MTL4850 System.

See the MTL web site ([www.mtl-inst.com](http://www.mtl-inst.com)) for the full specifications of the MTL4850 system components and accessories, and the MTL4500 Series isolators mentioned in this manual.

## 2 DESCRIPTION

The MTL4850 HART Maintenance System enables a user to calibrate, configure and maintain an entire network of 'smart' field devices from a single workstation.

The key element that makes this possible is the MTL4850 or MTL4854 modules, which provide the multiplexing for the individual field devices, making each one addressable and identifiable from the workstation.

The other important element is the terminal circuit board that simplifies the interconnection of the field devices to the multiplexer module. A range of terminal boards and backplanes has been designed to suit most general applications but custom versions can also be designed to suit individual OEMs and their applications.

*HART® is a registered trademark of the HART Communication Foundation*

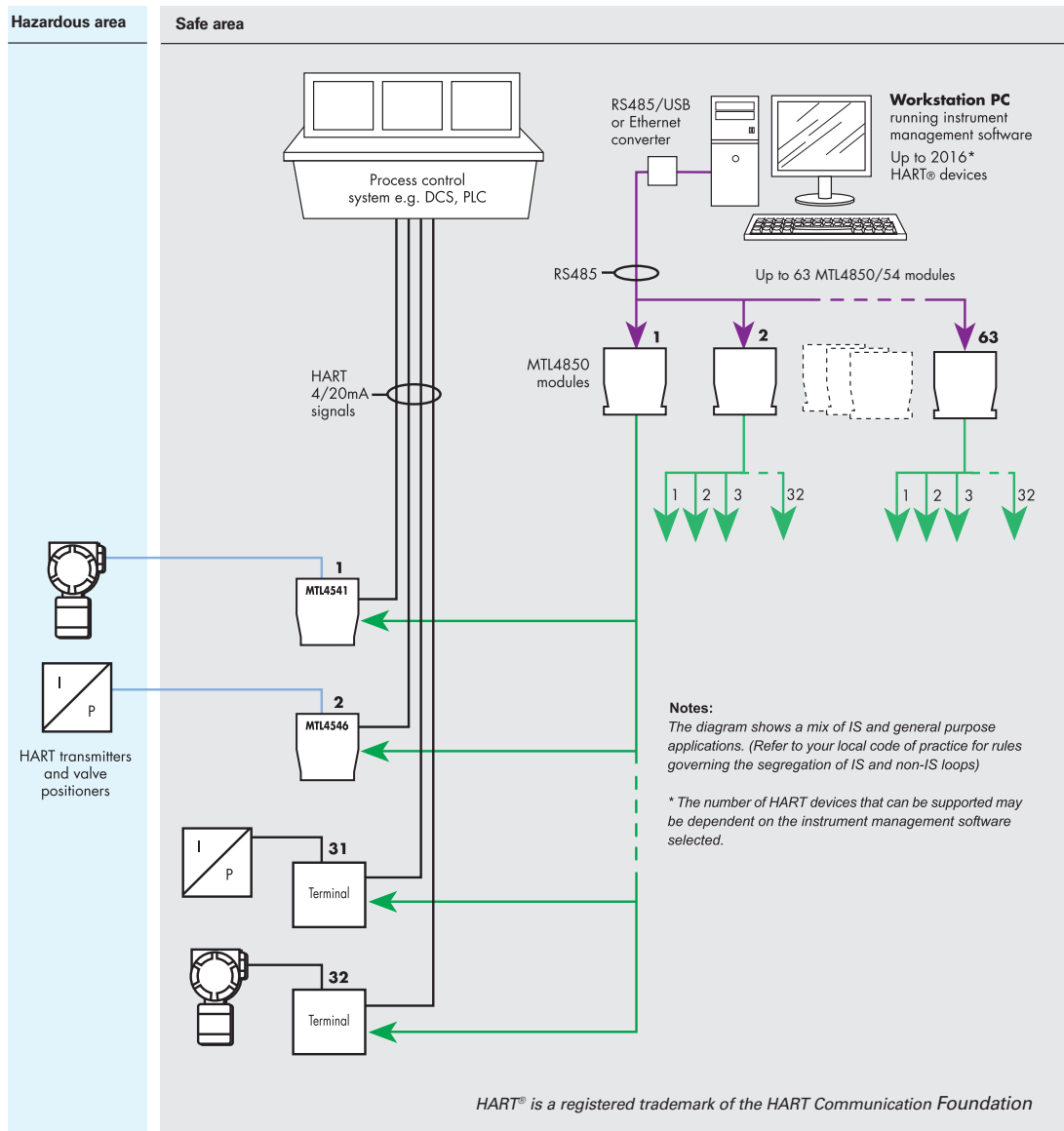

Figure 2.1- System Overview (typical installation)

The multiplexer module, MTL4850 or MTL4854, uses a plug-in style with fixing screws to provide a simple and secure installation method onto the backplane.

Up to 32 field devices can be accommodated by each HART multiplexer module, which is then connected via an RS485 to USB (or Ethernet) converter, to the PC running the HART maintenance software. Depending upon the management software, up to 63 of the multiplexer modules can be connected to it, making a potential count of 2016 smart field devices on one serial link. See Figure 2.1 for a diagrammatic impression of this structure.

For intrinsically safe applications, consideration must be given to the safety parameters for each field loop. For further information, please refer to MTL or your local representative.

The MTL4850 has a single HART modem to service the channels connected to the module whilst the MTL4854 has four HART modems. The latter enables simultaneous communication with multiple field devices through a single multiplexer, providing obvious benefits for applications where speed of data access is important.

**NOTE**

For any application of the multiplexers where connection is made to signals which are part of a safety instrumented system then the MTL4850 must be used. Refer also to the safety manual for the MTL4850 available from the MTL website.



## 2.1 General purpose or IS?

The MTL HART Management System can be used to control and maintain field devices that are located in a safe area or a hazardous areas.

**For safe areas,** HART Connection Units provide the necessary terminals to connect up to 32 field devices. These may be basic connection units, linked to a HART interface board, or they may be integrated units with an MTL4850 or MTL4854 multiplexer onboard. Section 2.3 explains this in more detail.

**Hazardous-area field devices** can be handled using IS isolating interfaces conveniently mounted on a backplane with facilities for onward connection to the host. Here also there is a choice of a backplane with an onboard HART multiplexer (CPH models), or legacy backplanes that can be linked to a HART interface board that carries the multiplexer(s).

Having the isolators mounted on a backplane dramatically reduces the amount of hand wiring required and therefore reduces the number of potential wiring errors. The hazardous-area wiring terminates on the isolating modules, *not the backplane*, consequently the backplanes do not need IS certification.

## 2.2 Generic or custom?

A range of generic connection units is available for both input and output field-device wiring. These are not designed for any particular DCS type and may be used universally.

The alternative is to choose a connection unit or backplane that integrates with the type of DCS being used on the plant. The key advantage of this method is the use of a DCS's specific connector type, which simplifies the wiring of the connection units into the system. Various solutions are available to suit individual DCS types and a listing of the currently available connection units and backplanes is given in Appendix A.

## 2.3 Connection methods

There are currently three methods for linking the HART signals to the MTL4850 or MTL4854:

- using an integrated connection unit – HTP-SC32- see Figure 2.2
- via a connection unit to a HART interface (HMP-HM64)- see Figure 2.3
- using an IS isolator backplane with a HART interface- see Figure 2.4

NOTE
the MTL4850/54 may also be used to update existing HART installations, but these methods are not discussed here. Consult MTL for information if this is of interest.

The self-contained (non-IS) connection unit- see Figure 2.2- is a 32 channel connection unit with screw terminals for the field devices and the main system, and an integrated multiplexers. Up to 63 of these connection units can be daisy-chained on an RS485 link to a PC running HART maintenance software. Apart from an RS485 to USB (or Ethernet) protocol converter, no other external hardware is required.

See Section 4.1 for details.

**Figure 2.2**  
self-contained  
HTP-SC32

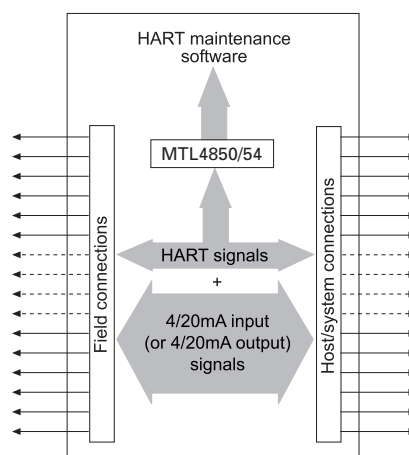

The second alternative- see Figure 2.3- is to use one of MTL's HART connection units:

- HCU16 16-channel analogue input/output
- HCU16AO 16-channel analogue output with HART filters

and link to an HMP-HM64 HART interface, which can accommodate any combination of four of these connection units.

**Figure 2.3**  
HART  
connection unit

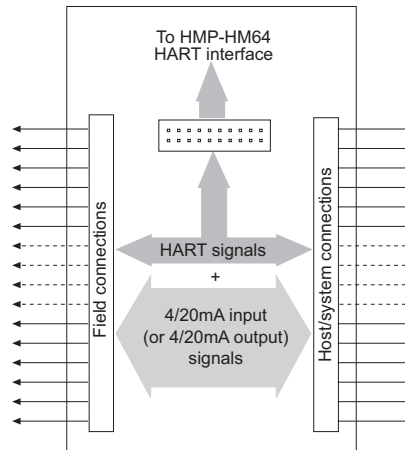

The HMP-HM64 is a compact interface between the connection units and the maintenance system. Up to 32 of these can be daisy-chained on an RS485 link to a PC running HART maintenance software, making a total coverage of 2016 channels. See Sections 4.2 to 4.5 for details.

The final method considered here consists of two backplane options.

- 16-channel backplane CPH-SC16 and CPH-SC16R
- 32-channel backplane CPH-SC32 and CPH-SC32R

Both backplanes accommodate 16 MTL4500 Series IS isolator modules and an MTL4850 or MTL4854 multiplexer module.

**Figure 2.4**  
HART CPH-SCxx  
backplane

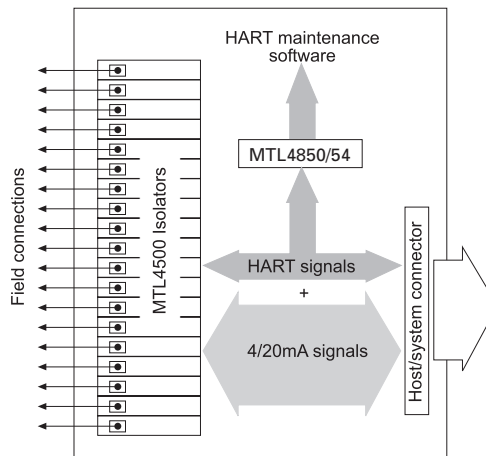

The CPH-SC16 backplane is designed for MTL4541 single channel isolators and has 16 field terminals, while the CPH-SC32 has 32 field terminals for MTL4544/4544A dual channel isolator modules.

RS485 ports on the backplanes enable them to be connected to the HART maintenance software PC.

In addition, both backplanes have a facility to accept dual (redundant) power supplies for maximum system availability.

### 3 SAFETY INFORMATION

Before beginning the installation of any of this equipment it is **IMPORTANT** that the information in this section is read and understood.

#### 3.1 Precautions - General



**WARNING!**

Units **MUST NOT** be installed in a hazardous area unless certified and marked for this purpose or unless protected by a locally accepted explosion-proof technique.

- Make sure all installation work is carried out in accordance with local standards, codes of practice, and site regulations.
- Check that the hazardous-area equipment complies with the descriptive system document.
- If in doubt, refer to the certificate/catalogue for clarification of any aspects of intrinsic safety or contact MTL, or your local representative, for assistance.
- Check that the interface unit(s) functions(s) are correct for the application.

### 4 INSTALLATION

This section details the methods used to implement the connection options outlined in Section 2.3.

#### 4.1 HTP-SC32 HART connection unit

As a simple solution for handling the HART maintenance signals passing to and from the field devices the HTP-SC32 will often be the primary method of choice. It is intended for analogue input signals but may also be used for analogue outputs if the host system is compatible with HART communications.

Able to handle up to 32 channels through its screw-clamp field and system terminals, it is a convenient way to integrate HART maintenance facilities. The HTP-SC32 provides a self-contained solution because the MTL4850/54 HART multiplexer is already on-board and requires only DC power and a simple RS485 link to the host management PC to get started.

Two terminals are provided for each channel enabling connections to be made to 2-wire transmitters, 4/20mA current loops or voltage inputs. Each channel is isolated so it may be connected to any suitable point in the analogue loop, and input and output types may be mixed.

HART signals have to be terminated into an impedance of >240 Ω, so provision is made on the circuit board to fit parallel resistors - normally 250 Ω - or a series resistor if the input impedance at the point of connection is <240 Ω. Various models are available to suit these termination options. Table 4.1 identifies the models and their specific differences and Figure 4.2 shows how these models are used.

**Figure 4.1**  
HTP-SC32  
backplane

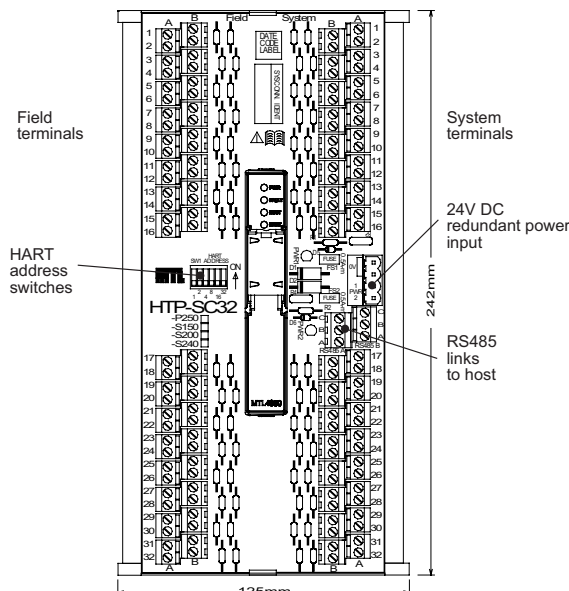

Model	Description
HTP-SC32	no parallel resistor, zero ohm link fitted in series (used for current inputs with 250 $\Omega$ input impedance or HART compatible outputs)
HTP-SC32-P250	250 $\Omega$ parallel resistor, zero ohm link fitted in series (used for 1–5V system inputs)
HTP-SC32-S150	no parallel resistor, 150 $\Omega$ resistor fitted in series (used for current inputs with 100 $\Omega$ input conditioning)
HTP-SC32-S200	no parallel resistor, 200 $\Omega$ resistor fitted in series (used for current inputs with 50 or 63.5 $\Omega$ input conditioning)
HTP-SC32-S240	no parallel resistor, 240 $\Omega$ resistor fitted in series (used for outputs with isolator connected to field terminals. Use HMU16AO for direct connection to field device)

**Table 4.1**  
HTP-SC32  
model  
options

#### 4.1.1 Application examples

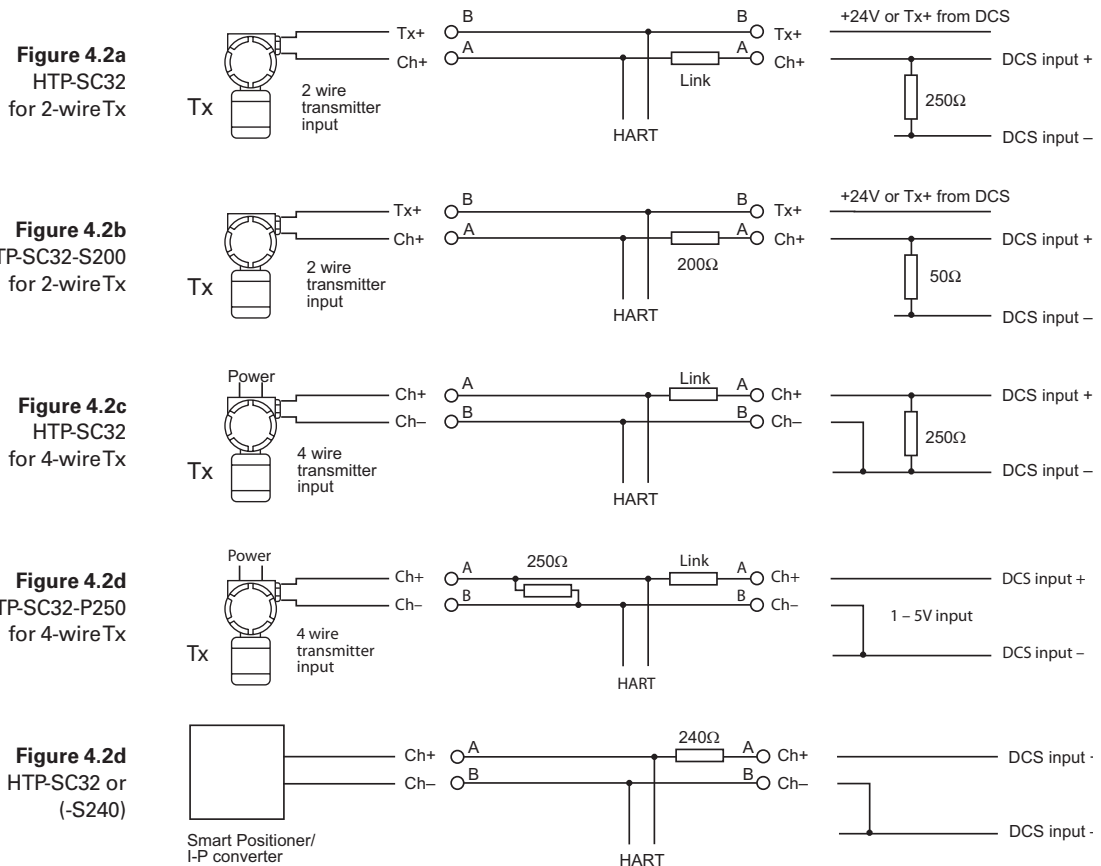

#### 4.1.2 Mounting

The HTP-SC32 is designed for mounting in a control room equipment cabinet and is supplied fitted on a carrier suitable for T or G section DIN-rail mounting in any orientation.

Carrier weight: 500g

Module weight: 120g

Footprint dimensions: See Figure 4.1

Height (modules fitted): 152mm from top of DIN rail

#### 4.1.3 RS485 communication connections

Two RS485 ports are provided on the board - see Figure 4.2. These are used to connect the HTP-SC32 to the PC running the maintenance software and to onward link to other HTP-SC32 or similar HART interfaces.

Full details of this communications link are provided in Sections 4.12.

**Figure 4.3**  
DC power connections

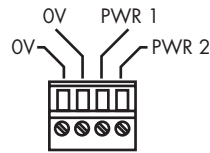

**4.1.4 DC power connections**

The HTP-SC32 has a removable, 4-way, screw-clamp terminal connector that provides redundant 24V dc supply connections. LED indicators are provided to indicate the presence of power to each of the redundant power inputs. A series diode in each supply input means that the higher of the two voltage supplies is used and there is an automatic switch-over of supplies if one fails. A 0.5A inline fuses protect against over current.

Power requirements: Voltage: 20–35V dc  
Current: 75mA @ 24V dc

Connect the dc power to the board as shown in Figure 4.3.

**4.1.5 HART addressing**

A 6-way DIP switch (SW1) is provided on the circuit board to enable a unique HART address to be set for the HART multiplexer. The switch is binary coded and the relevant ‘bits’ should be switched to the ON position. See Section 5.3.2 for additional information.

**4.2 HMP-HM64 HART interface**

Designed to be connected to remote connection units or backplanes via ribbon cables the HMP-HM64 HART interface provides the user with an interface easily configurable and expandable to meet system requirements. It accommodates two MTL4850/54 HART multiplexer modules and is therefore capable of supporting 64 channels itself: it can also be daisy-chained with others to support further channels on one serial RS485 link.

**Figure 4.4**  
HMP-HM64 connections

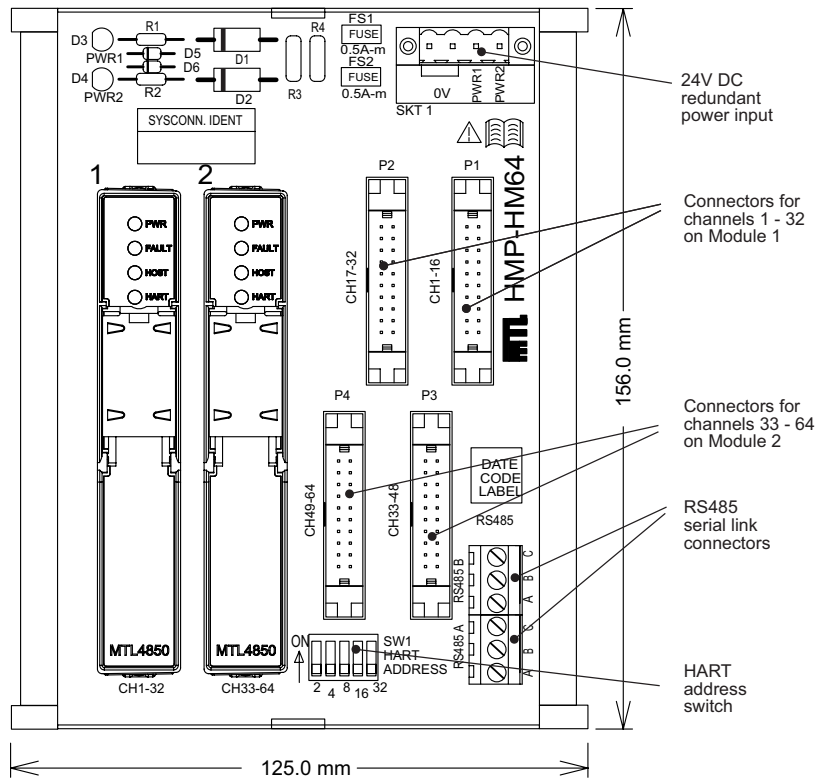

#### 4.2.1 Mounting

The HMP-HM64 is designed for mounting in a control room equipment cabinet and is supplied fitted on a carrier suitable for T or G section DIN-rail mounting in any orientation.

Carrier weight: 230g

Module weight: 120g per module

Footprint dimensions: See Figure 4.4

Height (including module/s): 152mm from top of DIN rail

#### 4.2.2 Ribbon cable connectors

Four 20-way ribbon cable connectors (P1– P4) are provided on the HMP-HM64 to receive the HART signals coming from connection units- HCU16 or HCU16AO- or backplanes equipped with similar DIN41651 connectors. See Figure 4.4 and 4.5 for details.

P1 and P2 connect to multiplexer module 1 and P3 and P4 connect to module 2. Each one provides 16 signal connections and 4 ground returns to the module. The HM64RIB20 cable is used for this purpose and is available in standard lengths from 0.5 up to 6 metres. This cable is intended for use within a cabinet to link the connection units to the HART multiplexer, and is not ruggedised for applications outside of the cabinet environment.

#### 4.2.3 RS485 communication connections

Two RS485 ports are provided on the board- see Figure 4.4. These are used to connect the HMP-HM64 to the PC running the maintenance software and to onward link to other HMP-HM64 or similar HART interfaces.

Full details of this communications link are provided in Sections 4.12.

#### 4.2.4 DC power connections

The HMP-HM64 has a removable, 4-way, screw-clamp terminal connector that provides redundant 24V dc supply connections. LED indicators are provided to indicate the presence of power on each of the redundant power inputs. A series diode in each supply input means that the higher of the two voltage supplies is used and there is an automatic switch-over of supplies if one fails. A 0.5A inline fuses protect against over current.

Power requirements: Voltage: 20–35V dc

Current: 130mA @ 24V dc (with both modules fitted)

Connect the dc power to the board as shown in Figure 4.3.

#### 4.2.5 HART addressing

A 5-way DIP switch array (SW1) is provided on the HMP-HM64 circuit board to enable unique HART addresses to be set for the two MTL4850 modules. The switch is binary coded, but the HMP-HM64 has only *even* number address setting options 0, 2, 4, 8, 16 and 32. This is because the board will accommodate *two* modules but it is only necessary to set the address of *one* of them, the other adopts the *odd* address immediately above it. Consequently, the address switch defines the address of module 1 and module 2 uses the address above.

For example, if the address switch is set to 24 (i.e. switch 8 and 16 are set ON) then module 1 will take the address 24 and module 2 (if it is fitted) will be at address 25.

Figure 4.5 HMP-HM64 connections

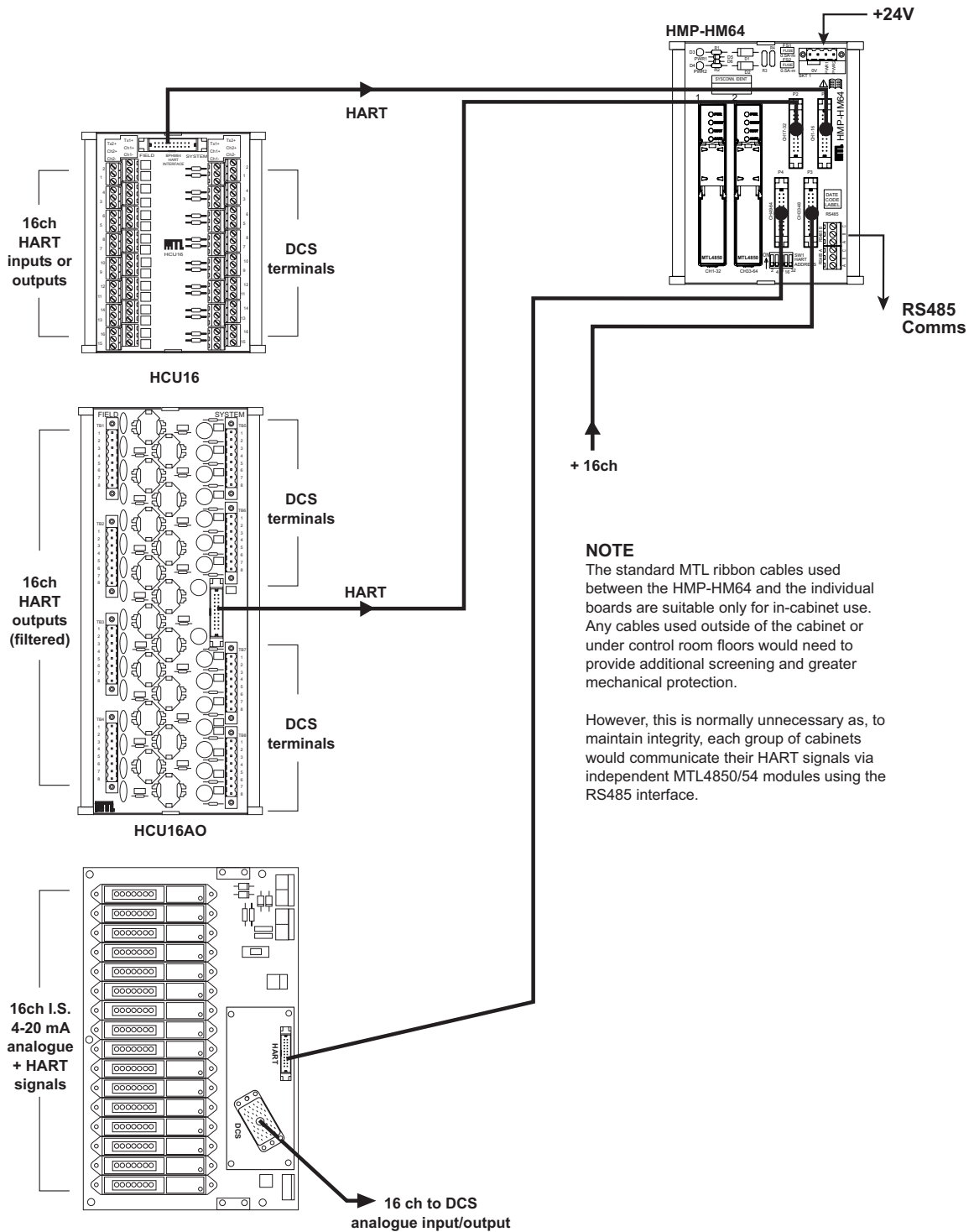

### 4.3 HCU16 HART connection unit

The HCU16 HART connection unit- see Figures 4.6 & 4.7- provides a connection interface between the field wiring and the onward link to the host/system control for non-hazardous areas. It also provides a take-off point for the HART signals to the maintenance system.

Each channel has three terminals: +ve, -ve and a transmitter supply terminal (Tx +) – see Figure 4.6. The HART signal has to be terminated with an impedance of approximately 240 . Positions are provided on the circuit board to fit parallel resistors (normally 250 ), or an appropriate series resistor to raise the impedance if it is < 240 . This unit can be used with analogue outputs if the system's current signal is compatible with HART communications.

Connections to the field signals and the system are via screw-clamp terminals.

#### 4.3.1 Mounting

The HCU16 is designed for mounting in a control room equipment cabinet and is supplied fitted on a carrier suitable for T or G section DIN-rail mounting in any orientation.

Carrier weight: 330g

Footprint dimensions: See Figure 4.6

Height: 53mm from top of DIN rail

#### 4.3.2 Ribbon cable connector

A 20-way ribbon cable connector is provided on the HCU16 to link to the HMP-HM64.

**Figure 4.6**  
HCU16  
connection unit

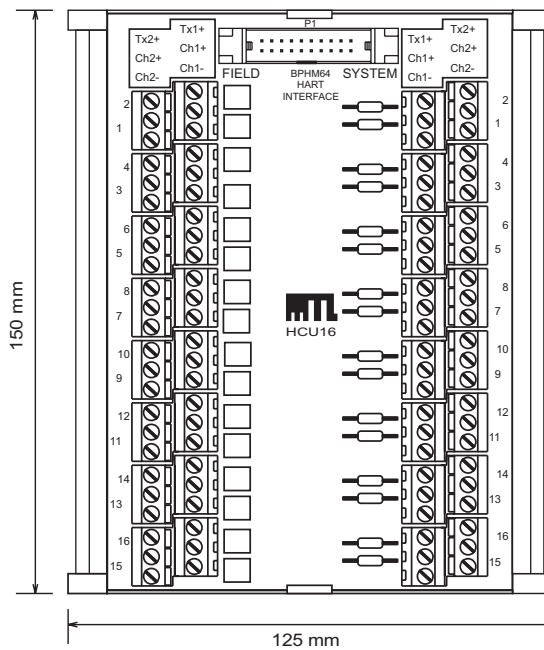



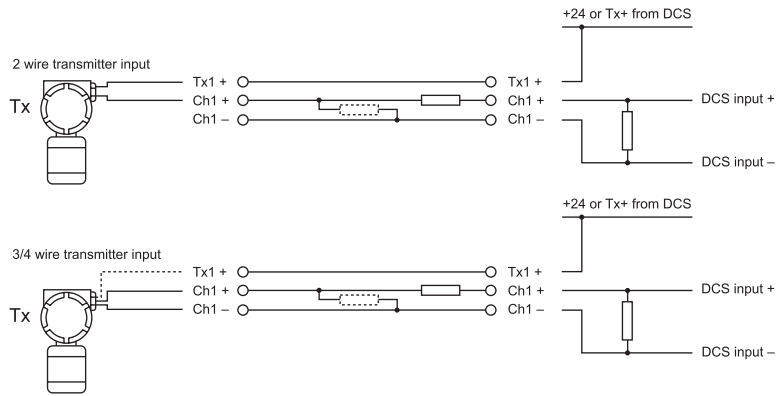

**Figure 4.7**  
HCU16  
schematic diagram

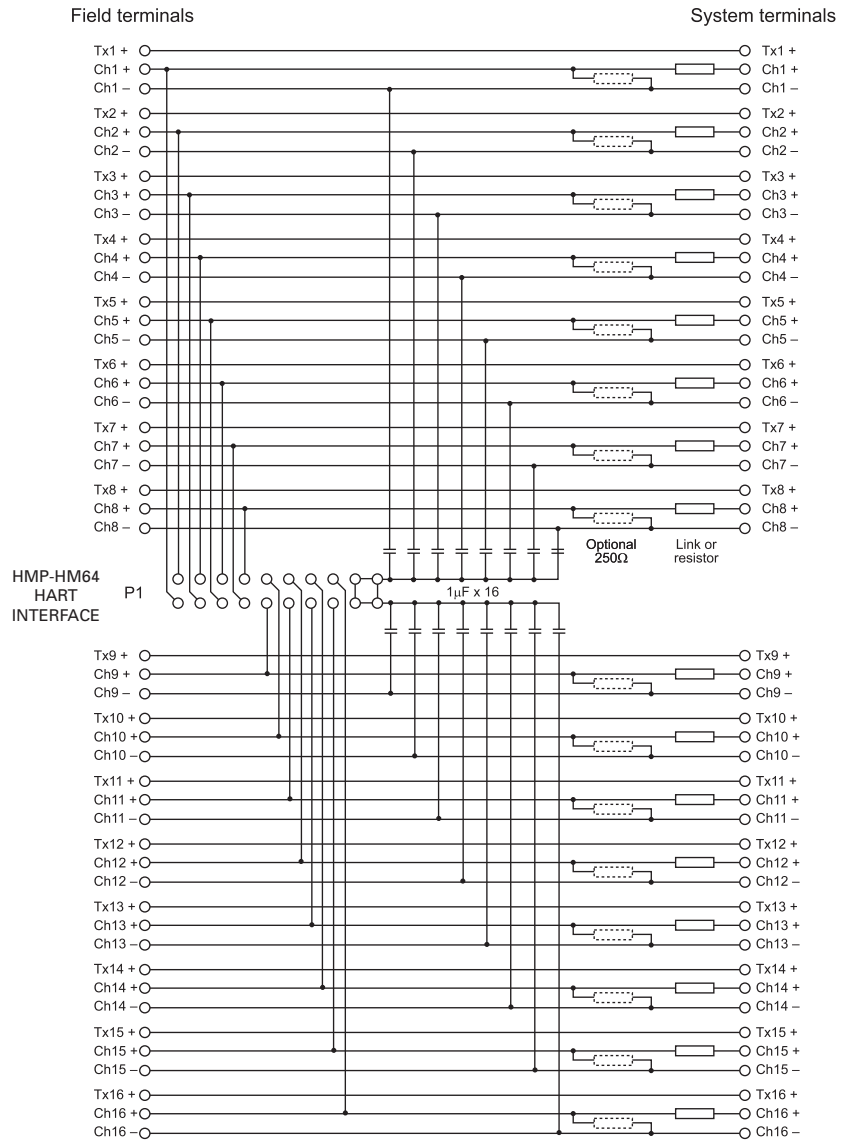

#### 4.4 HCU16AO HART connection unit

Many older instruments have 4-20mA analogue outputs that are not compatible with HART data because their impedance is normally too low for the HART to operate correctly. In addition, the noise generated by the analogue output can sometimes interfere with the HART data, or sometimes the HART signal can even affect the stability of the current signal.

The HCU16AO HART connection unit - see Figure 4.8 & 4.9- enables HART signals to be used in current output loops, in non-hazardous areas. It has 16 isolated channels, each with a low-pass filter in series with the current signal from the system. This has virtually no effect on the 4-20mA signals but presents a suitable high impedance (> 240 ) to the HART signals for their detection and measurement.

Field and system connections are made via pluggable 8-way, screw-clamp terminals, in 4 groups of 4 channels.

##### 4.4.1 Mounting

The HCU16AO is designed for mounting in a control room equipment cabinet and is supplied fitted on a carrier suitable for T or G section DIN-rail mounting in any orientation.

Carrier weight: 770g (nominal)

Footprint dimensions: See Figure 4.8

Height: 58mm from top of DIN rail to top of screw connectors

##### 4.4.2 Ribbon cable connector

A 20-way ribbon cable connector is provided on the HCU16AO to link to the HMP-HM64.

**Figure 4.8**  
HCU16AO  
connection unit

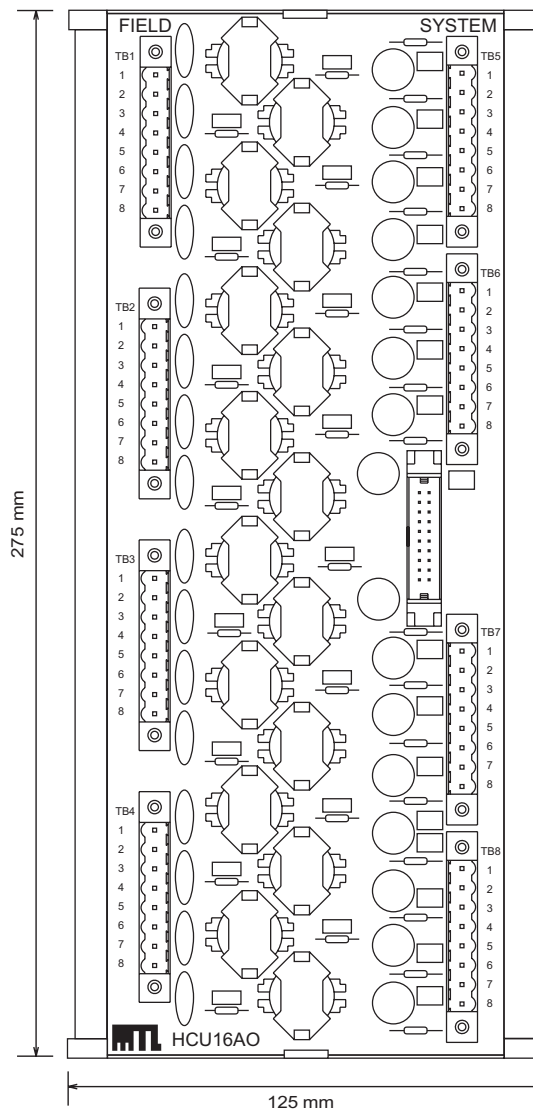

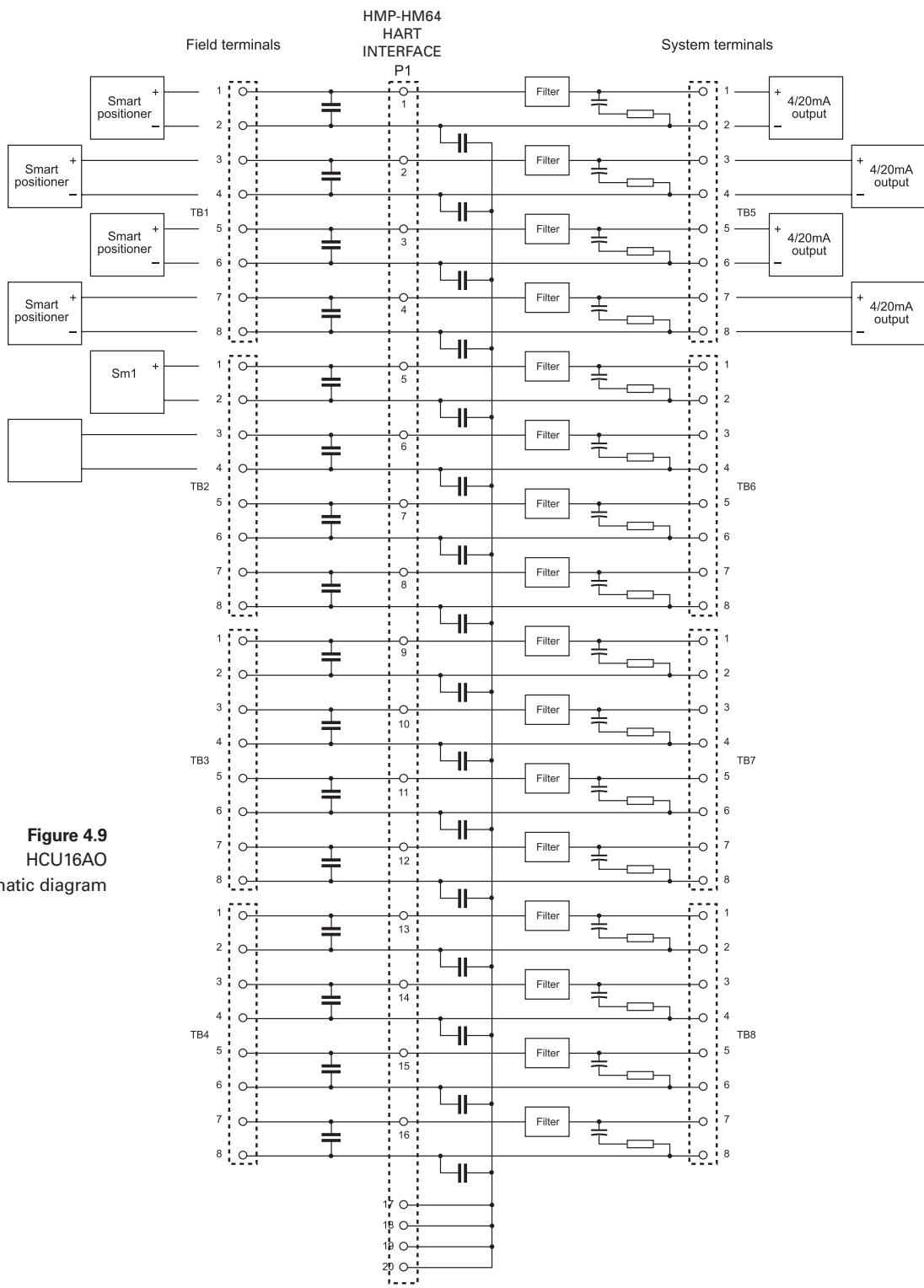

**Figure 4.9**  
HCU16AO  
schematic diagram

## 4.5 MTL customised backplanes

MTL has a range of customised backplanes that accept MTL4500 Series isolators. These have been produced for various types of DCS and PLC equipment and have system connectors that suit the equipment type. Many are fitted with a DIN41651 20-way ribbon cable connector to enable the backplane to be connected to a HART maintenance system. Check with MTL for availability.

Other types of backplane are available that have provision for the inclusion of an MTL4850/54 module on the backplane itself. These are dealt with in the next section.

## 4.6 CPH-SC16(R) and CPH-SC32(R) backplanes

The CPH-SC16, CPH-SC16R, CPH-SC32 and CPH-SC32R backplanes are designed for use with the MTL4500 series analogue input and output modules. Each backplane can accommodate 16 x MTL4500 modules as well as an MTL4850/54 HART multiplexer module.

### 4.6.1 CPH-SC16 and CPH-SC16R backplanes

Each of these backplanes will support 16 HART channels, but a second CPH-SC16 (or 16R) backplane can be connected to utilise the 32 channel capacity of the MTL4850/54. They are designed primarily for use with the MTL4541, or MTL4541A, analogue input modules and the MTL4546 analogue output modules.

The CPH-SC16R version has 250 resistors across each of the control system terminal to provide a 1–5V signal for the host. Only the MTL4541 and MTL4541A modules may be used with this version.

Connectors P1 and P2 at each end of the backplane are provided for linking a pair of CPH-SC16 (or 16R) backplanes to utilise the full 32 channel capacity of the MTL4850/54. See Section 4.11 for additional details.

If a pair of backplanes is linked in this way, only one will have the multiplexer modules fitted. The MTL4850/54 is fitted to the backplane that carries modules 1–16: the RS485 serial link should also be connected to this backplane.

### 4.6.2 CPH-SC32 and CPH-SC32R backplanes

Each of these backplanes will support 32 HART channels. They are designed primarily for use with the MTL4544, or MTL4544A analogue input modules and the MTL4549, or MTL4549C, analogue output modules.

The CPH-SC32R version has 250 resistors across each of the control system terminal to provide a 1–5V signal for the host. Only the MTL4544 modules may be used with this version.

### 4.6.3 RS485 communication connections

All of these backplanes have two RS485 ports fitted - see Figure 4.10 and 4.11 - to connect the backplane to the PC running the maintenance software and to onward link to other backplanes or similar HART interfaces. If a pair of backplanes is linked, the RS485 serial link should be connected only to the one carrying the MTL4850/54.

Full details of this communications link are provided in Sections 4.12.

### 4.6.4 DC power connections

The backplanes have dual redundant 24V dc supply feeds via independent 4-way, screw-clamp, terminal connectors. LED indicators are provided to indicate the presence of power to each of the redundant power inputs. Inline input diodes prevent interaction between the two power supplies and 0.5A fuses protect against over current.

#### Power requirements

Voltage:	20–35V dc
Current (with all channels at 20mA):	0.65A max. @ 24V dc - CPH-SC16(R) 1.2A max. @ 24V dc - CPH-SC32(R)

See Section 4.10.3 for connection details.

### 4.6.5 HART addressing

A 6-way DIP switch (SW1) is provided on the backplane to enable a unique HART address to be set for the MTL4850 or MTL4854. The switch is binary coded and the relevant 'bits' should be switched to the ON position. See Section 5.3.2 for additional information.

Figure 4.10 CPH-SC16(R) backplane

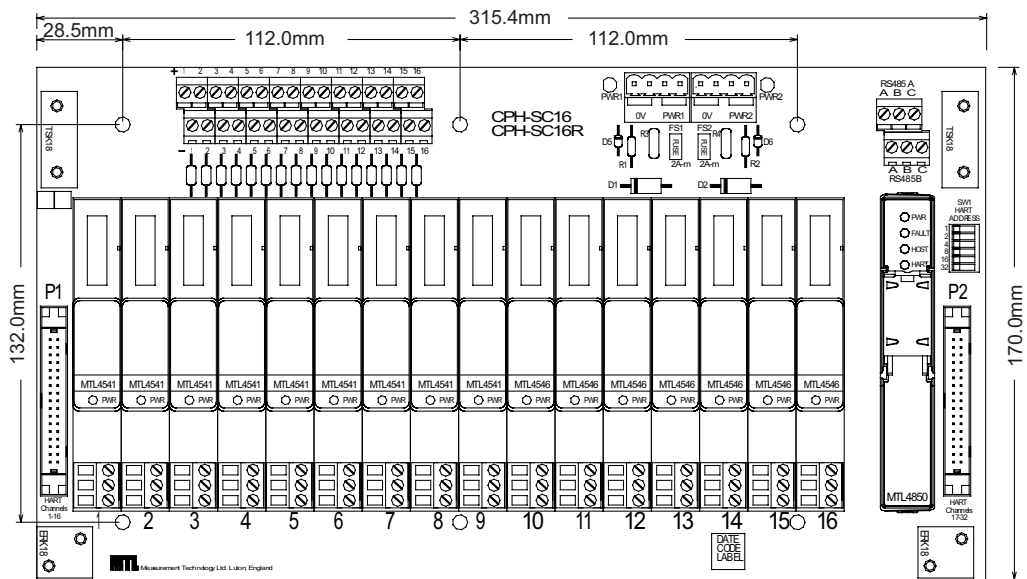

Carrier weight: 415g (nominal)

Figure 4.11 CPH-SC32(R) backplane

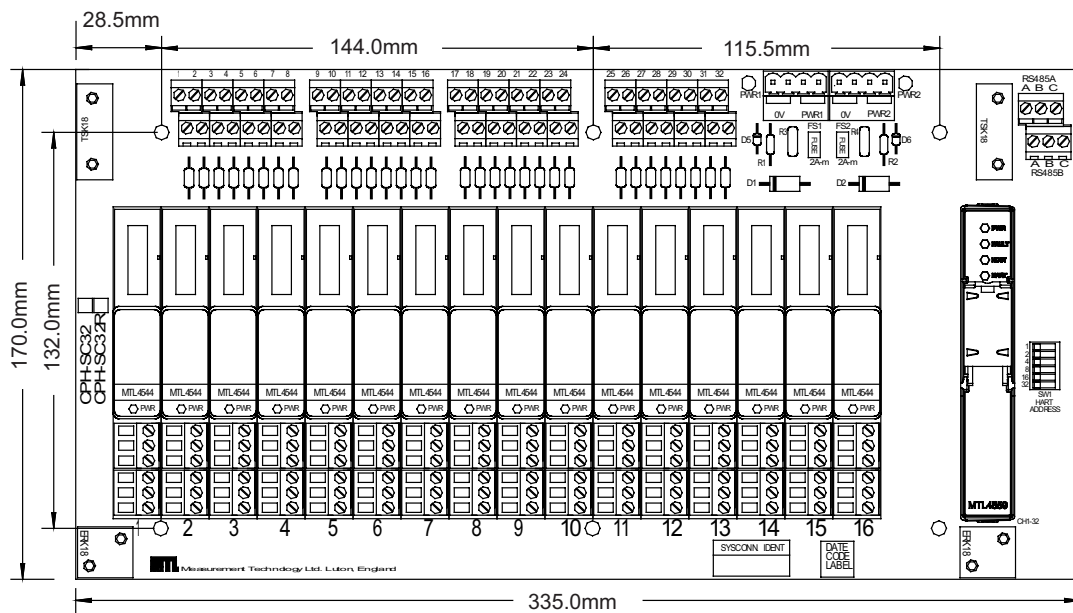

Carrier weight: 420g (nominal)

## 4.7 Backplane mounting

### 4.7.1 Surface mounting

4.7.2 Surface mounting kit (type SMS01) is available for this purpose. SMS01 contains 40 sets of the components shown in Figure 4.12.

**Figure 4.12**  
Surface mounting  
kit  
components and  
assembly details

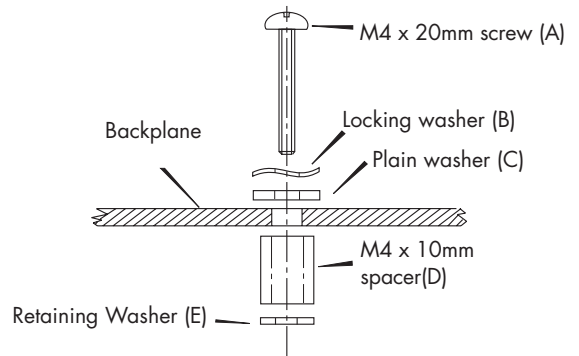
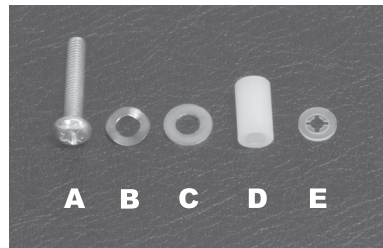

#### Prepare panel

- Refer to Figure 4.10 or 4.11 for mounting hole positions.
- Prepare holes in the mounting surface at the centres shown. Thread these (M4) if retaining nuts will not be used.

#### Fit backplane

Refer to figure 4.12.

- Select an M4 x 20mm screw (A).
- Place a locking washer (B) and a plain washer (C) over it.
- Insert the screw through a fixing hole on the baseplate.
- Fit a 10mm spacer (D) and retain it with washer (E).
- Repeat steps a) to d) for the other five (5) mounting holes.
- Attach the baseplate using the prepared panel holes. Retain the screws with a suitable nut if the holes are not tapped.

### 4.7.3 DIN-rail mounting – with DIN-rail mounting kit DMK01

DIN-rail mounting kits (type DMK01 or DMK04) are available for this purpose. DMK01 contains 40 sets of the components shown in Figure 4.13, while DMK04 contains 4 sets of these components.

**Figure 4.13**  
DIN-rail mounting  
kit  
components and  
assembly details

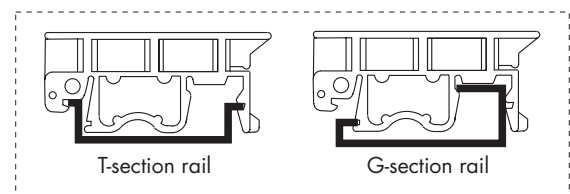
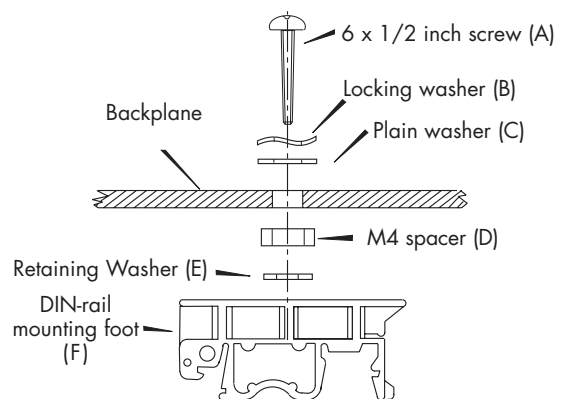
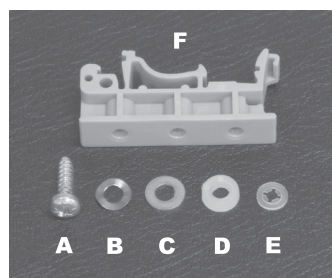

### Fit backplane

Refer to figure 4.13.

- a) Select a mounting screw (A).
- b) Place a locking washer (B) and a plain washer (C) over it.
- c) Insert the screw through a fixing hole on the baseplate.
- d) Fit a spacer (D) and retain it with washer (E).
- e) Repeat steps a) to e) for the other five (5) mounting holes.
- f) Fit the mounting feet (F) onto the DIN-rail in roughly the correct positions.
- g) Offer up the baseplate to the mounting feet on the DIN rail, locate the screws into the middle holes in the feet and secure each in turn. Return to tighten each screw before finishing.

## 4.8 Backplanes – identification and tagging

A rectangular area for identification is provided on each backplane. In addition, tagging strips are available (TSK18) for mounting over the backplane safe-area connections. Two areas- marked 'B' in Figures 4.10 and 4.11- are provided with threaded inserts for attaching the tagging strip mounting posts.

**Figure 4.14**  
Tagging strip  
details  
(TSK18)

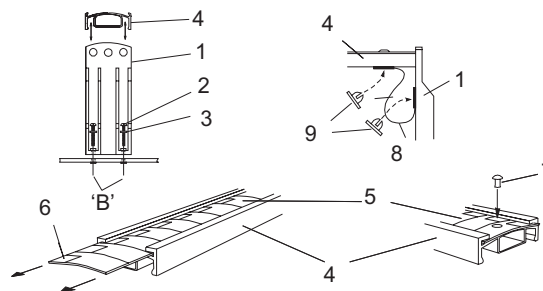

- a) Mount the tagging strip to the backplanes as follows:-
- b) Attach each tagging strip mounting post (1) with two M3 x 12 mounting screws (2) and washers (3).
- c) Attach colour coding labels (6) onto tag label (5).
- d) Mark tag label (5) with tag references.
- e) Slide tag label (5) into tag strip holder (4) and retain with plastic retaining rivet (7).
- f) Attach plastic retaining tie (8) with two plastic rivets (7).
- g) Clip tag strip holder (4) onto mounting posts (1) by pushing downwards.

## 4.9 Backplane earth rails

Optional earth rail kits are available (ERK18)- see Figure 4.15. Cable screens from hazardous-area circuits or spare pairs from a multicore cable can be connected to the terminals on the earth rails.

**Figure 4.15**  
Earth rail  
details  
(ERK18)

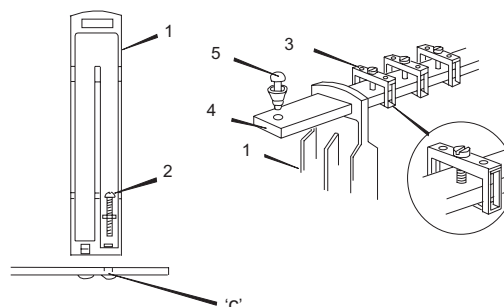

These are mounted on the backplane at the same height as the tops of the module, close to the hazardous-area connectors. Earth rails are attached using the following procedure:-

- a) Locate the earth rail mounting positions - marked 'C' in Figure 4.15- at each end of the backplane.
- b) Attach each mounting post (1) with two M3 x 12 mounting screws and washers (2).
- c) Fit the earth terminals (3) onto the rail (4).
- d) Insert the ends of the earth rail into the slots at the tops of the mounting posts.
- e) Finally, insert the plastic retaining rivets (5) into each end of the rail.

## 4.10 Backplanes – connections

### 4.10.1 Hazardous area - field wiring connections



#### WARNING!

Personnel that carry out connection of wiring to or from hazardous areas must be correctly trained. Unless this work is done correctly, it can endanger the lives of site workers and seriously damage equipment.

Hazardous area wiring is terminated on the isolator modules using the blue terminals provided on them. For full information on the wiring of MTL4500 isolators consult MTL publication INM4500.

### 4.10.2 Safe area - control system connections

Each channel is provided with a 2-way split-level terminal block for safe area signals. See Figure 4.16.

**Figure 4.16**  
Control wiring connections:  
CPH-SC16(R)  
shown as example

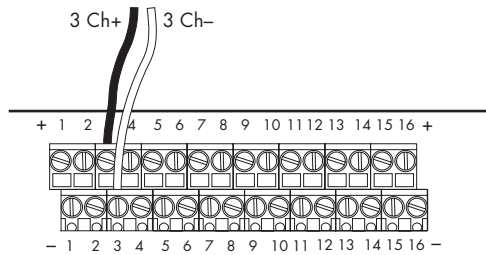

The numbering on the terminals corresponds to the channel number. In the case of the CPH-SC16(R), the terminal numbers correspond with the the module number; however, the CPH-SC32(R) is designed for dual channel isolators and so there are two sets of terminals per module.

The same channel terminals are used for input or output field devices because the backplane provides the required interconnections.

Maximum wire gauge is 2.5mm<sup>2</sup> (12 AWG) and the wire enters from the side of the block.

### 4.10.3 Power supply connections

All of the CPH-SCxx backplanes have provision for dual, redundant 24V dc power supplies. The supplies have individual, screw-terminal, plug-in connectors and two LEDs are provided on the backplane to indicate which supplies are operational. A series diode in each supply input means that the higher of the two voltage supplies is used and there is an automatic switch-over of supplies if one fails.

Connect each of the two power supply connectors to the independent supply sources according to the terminal assignments shown in Figure 4.17.

**Figure 4.17**  
Redundant power supply wiring for backplanes

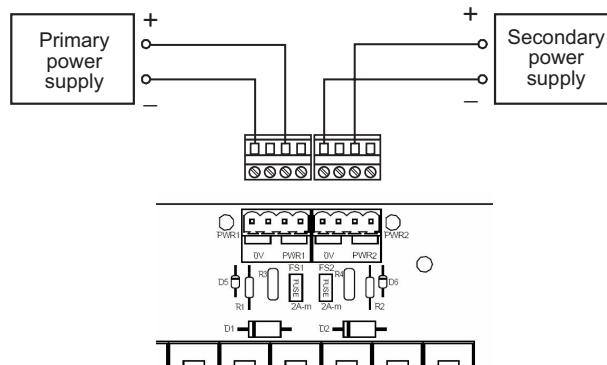

The maximum wire size is 2.5mm<sup>2</sup> (12AWG).

Plug the connectors into the sockets on the backplanes.

The backplane has two fuses, one for each power supply. These fuses are rated at 2.0A and may be obtained as accessory FUS2.0ATE5 which contains 10 spare fuses.



#### 4.10.4 Safe area – ring-mained power supplies

A “ring main” system can be used to distribute power to these backplanes in a safe area . This permits individual backplanes to be taken out of service without affecting supplies to other backplanes. Two or more backplanes can be removed, provided they are neighbours, without disrupting the supply to other backplanes. Make the connections as shown in Figure 4.18.

**NOTE**

Backplanes can be ring-mained providing the maximum circuit current does not exceed 12A. Wire sizes up to 2.5mm<sup>2</sup> (12AWG) can be used and should be chosen according to load and voltage drop.

**Figure 4.18**  
Supply circuit  
for interconnecting  
backplanes

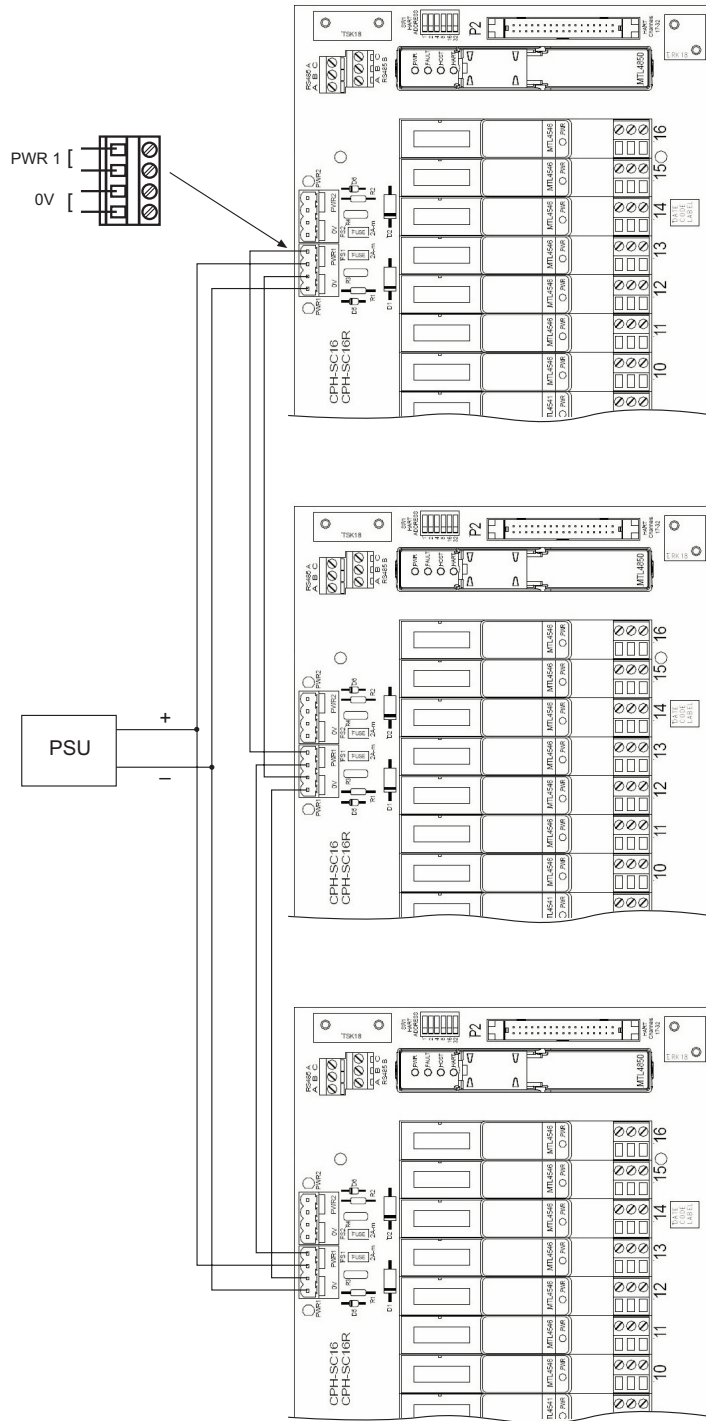

## 4.11 Cabling recommendations

### 4.11.1 HART signals cable

HART signal cables are used to connect the CPH-SC backplane with a HART connection unit or an IS backplane. This connection is made with a 20-way ribbon cable.

Standard lengths of this 20-way cable are available from MTL using the part number HM64RIB20-x.x, where the x.x denotes lengths between 0.5 and 6.0 metres.

Connector type	20-way DIN 41651 bump polarised
Cable	0.05 inch pitch standard ribbon
Maximum length	15m / 50ft

### 4.11.2 Backplane interface bus

The interface bus provides a connection between two CPH-SC16 or CPH-SC16(R) backplanes to provide an additional 16 modules to the MTL4850/54. This connection is made via a 34-way ribbon cable between connector P2 on the backplane carrying the multiplexer and connector P1 on the backplane carrying only the additional modules as shown in Figure 4.19.

**Figure 4.19**  
Redundant power supply wiring for backplanes

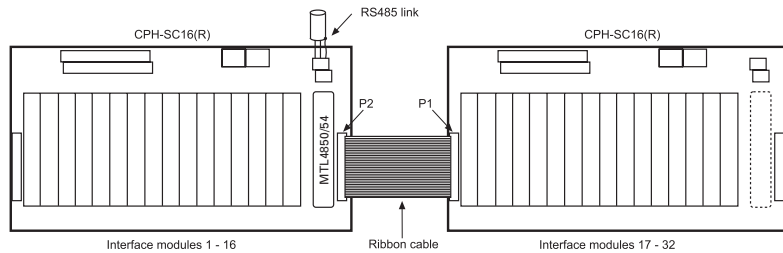

Standard lengths of this 34-way cable are available from MTL using the part number HM64RIB34-x.x, where the x.x denotes length, as shown below.

Connector type	34-way DIN 41651 bump polarised
Cable	0.05 inch pitch standard ribbon
Length	0.2, 0.5, 1.0 or 2.0 metres

## 4.12 RS485 connection

### The RS485 physical layer

Most PCs running instrument maintenance software masters use RS232 or USB for serial communication; however, this interface type does not allow the communications network to extend beyond 10 to 20 metres in length.

MTL have chosen to use an RS485 serial interface, which includes tri-state operation, and allows network lengths of up to 1000 metres and operates with data rates between 1200 and 38k4 baud when used with the MTL4850 or MTL4854. RS485 also allows the simple parallel connection of a number of units.

#### NOTE

When an RS232 master is used, a data converter must be inserted.

### The RS485 serial interface standard

For the purposes of this document RS485 can be regarded as a 2-wire, half-duplex, differential, multi-drop (32 nodes), communications standard. The RS485 standard defines the characteristics of the drivers and receivers that can be connected to the bus. It does not define the cabling or connectors used, nor does it specify a particular data rate or signal format.

#### Terminations

RS485 interfaces should ideally be provided with a 'matched' termination to prevent reflections and ringing of the signal on the bus cabling. The termination is usually a simple resistive terminator, with an impedance that matches the characteristic of the cable- this will normally be in the range of 100- 200Ω.

#### Biasing

When no communication is taking place, the bus is in an undefined, floating state and, consequently, noise on the bus may be decoded as real characters. Well-written software

should discard most of these characters, but the system may be further protected by biasing the bus to a known state and thereby preventing the reception of 'false' characters.

MTL4850 multiplexer modules from MTL have no built-in facility for terminating or biasing the network; as this is often provided by the RS232/RS485 converter.

#### 4.12.1 RS485 2-wire interconnection

The MTL4850 system uses a 2-wire connection as shown below:

**Figure 4.20**  
2-wire  
bus system

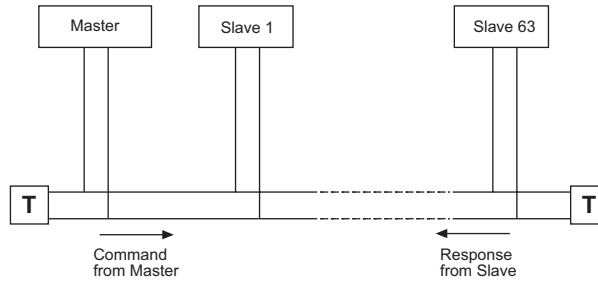

This 2-wire bus uses the same pair of wires to transmit queries from the master and responses from the slave.

The MTL4850/54 multiplexer module connects to the maintenance workstation via a 2-wire link, accessible from the RS485 Port connections on the backplane. Up to 63 MTL4850/54 modules (slaves) can be connected to a single Master maintenance workstation, as shown in Figure 4.20.

Connect the bus to the backplane as follows using a screened cable, for example Belden 8132 or 9841.

**Figure 4.21**  
RS485 port  
connectors

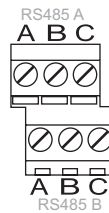

- Connect the two cores of the RS485 cable to screw terminals A & B of Port A on the backplane- see Figure 4.21.
- Connect the cable screen to terminal C.
- If multiple backplanes are to be connected, use Port B to loop to Port A of the next backplane. To avoid spending time in troubleshooting, it is suggested that the same colour convention is used for all connections to backplane terminals A and B, e.g. red to A, black to B.

#### NOTE

No damage will occur if the signalling lines are connected with the wrong polarity. The system will not operate in this case but all that has to be done is to reverse the two connections to make it operate correctly.

#### 4.12.2 Data converters

Most PCs used to run instrument maintenance software masters do not have a built-in RS485 interface so the following conversion options should be considered.

- Ethernet is in widespread use in modern installation and an Ethernet to RS485 gateway enables the workstation to be located at greater distances and use the installed wiring to pass data effectively across a site when necessary, without the need for additional wiring and repeaters to support the RS485 protocol. MTL can provide a suitable gateway on request – model number ET-485.
- USB to RS485 converters are convenient for local connection to a laptop computer when carrying out maintenance; however, this interface type does not allow the communications network to extend beyond 10 to 20 metres in length.
- RS232 to RS485 data converters are also available for use with earlier installations where RS232 is provided on the PC's serial COM port.

In all cases, follow the manufacturer's instructions for the installation and operation of the appropriate converter.

## 5 MODULES

### 5.1 MTL4850/54 – installation

Place the module over its marked connector in the position on the backplane, press it *evenly and fully* onto the backplane before tightening the two (captive) mounting screws. All safe-area circuit and power connections are made through this connector, so it must be seated properly on the backplane.

*If the module does not operate correctly, the module mounting should be the first point to check.*

### 5.2 Isolator modules (if used)

If the backplane accommodates isolators, refer to instruction manual INM4500/4600 for information on wiring hazardous-area connectors for MTL4500 Series isolators.

Position each isolator module in its appropriate location on the backplane. Ensure that the module is not tilted, which could damage the connector pins, then press it carefully to the backplane. All safe-area circuit and power connections are made through this connector.



#### WARNING!

Personnel that carry out connection of wiring to or from hazardous areas must be correctly trained. Unless this work is done correctly, it can endanger the lives of site workers and seriously damage equipment.

Hazardous area wiring is terminated on the isolator modules using the blue terminals provided on them. For full information on the wiring of MTL4500 isolators consult MTL publication INM4500/4600.

### 5.3 MTL4850/54 module parameters

#### 5.3.1 Setting and configuration

The speed for the RS485 interface is autodetected within the range 38400, 19200, 9600 or 1200 baud.

#### 5.3.2 HART address

Up to 63 MTL4850 / 54 multiplexer modules can be connected to a single maintenance workstation. Each multiplexer must have a unique address, which is set using the DIP switches located beside the module on the circuit board. The address switches are binary coded and the address is set by constructing the required number from the switch options provided, i.e. 1, 2, 4, 8, 16 and 32. For example, address number 29 would be set by putting switches 16, 8, 4 and 1 in the ON position ( $16 + 8 + 4 + 1 = 29$ ).

#### NOTE

the HMP-HM64 can only be set to *even* numbers as the other module adopts the *odd* addresses. See Section 4.2.5.

#### 5.3.3 Operation at power-up

The MTL4850/54 system is controlled by a host computer running instrument management software. Although the software is needed to operate the system, some checks can be made on the correct functioning of the hardware in isolation. These checks are made by observing the operation of the LEDs on top of the module.

##### 5.3.3.1 Correct operation

At power on, the power (PWR) LED should light and the multiplexer should start to build, or rebuild, an internal scan list of the HART loops connected to it. This will be indicated by a regular flashing sequence (equal on and off duration) of the Fault LED. At the end of this process the Fault LED should go OFF to indicate that it is now in its “running” state.

##### 5.3.3.2 Problems

If problems occurred during this power up sequence the Fault LED will either emit short and long flashes to indicate that it could not find any HART loops, or it will adopt a steady ON state to indicate that a fault was detected and the process of building the list was halted. The MTL4850/54 is delivered with the default of “scanning disabled.” In either case the instrument maintenance software can be used to change the multiplexer’s scanning mode.

##### 5.3.3.3 Scan list

Each loop connected to an MTL4850/54 is added to the scan list if a HART device is detected on power up or if the instrument maintenance software resets the module. Loops can be added individually or removed from the scan list using the “loop rebuild” facility in the instrument maintenance software.

##### 5.3.3.4 Scanning enabled

The MTL4850/54 scans continuously round all loops on the scan list.

## 6 FAULT FINDING AND ROUTINE MAINTENANCE

### 6.1 Maintenance precautions for MTL4500 modules

Most codes of practice permit live maintenance on intrinsically safe devices and systems, provided that precautions are taken to preserve the integrity of the device or system. During live maintenance of MTL4500 modules, the hazardous-area connectors that plug into the tops of the modules are likely to be removed, so the cables going into the hazardous-area connectors must be reasonably flexible in order to allow connectors to be inserted and removed easily from the module tops.

When a hazardous area connector is unplugged, care must be taken to ensure that it is not laid in a position where it could come into contact with the backplane or backplane components. The backplane is connected to safe-area circuits and is therefore not intrinsically safe. An unprotected connector could by-pass the essential segregation between the safe-area and hazardous-area circuits. This can be avoided by:

- a) plugging the connector into an MTL4599 dummy isolator or other uninstalled MTL4500 module directly upon removal (but NOT into any other module mounted on the backplane).
- b) providing some method of securing the connector temporarily so that it cannot touch the backplane or the safe-area circuits.

### 6.2 Fault finding on custom backplanes

When fault finding, carry out the following steps as far as is necessary:

1. Check the condition of the installation to make sure that no damage or deterioration has occurred.
2. Check that backplane power LEDs are ON. If not, check the power supply fuse(s) and, if necessary, change any of them.
3. Check that the (PWR) power LED on the MTL4850/54 module is ON. If not, and the circuit board power LED is ON, replace the module.
4. Exchange potentially faulty isolator modules as follows.
  - a) Unplug the hazardous-area connector(s).
  - b) Unclip and remove the module from the backplane.\*
  - c) Plug-in and secure the replacement unit on the backplane.
  - d) Replace the hazardous-area connector(s).
5. If an MTL4850/54 is changed, the HMS software does not recognise a replacement device until either:
  - a) the node name (stored within the MTL4850/54) is made the same as that of the removed device, using the HMS software.
  - b) the network is rebuilt; when the software will adopt automatically the node name of the replacement device.

\* Potentially faulty modules should be tested in workshop conditions. Consult the instruction manual for details of how to test a module.

LED	Colour	State	Description
PWR	green	Off	Multiplexer is not receiving power
		On	Multiplexer is receiving power
FAULT	red	Off	Multiplexer is in the running state
		Steady flash	Multiplexer build/rebuild is in progress
		Short/long flash	No HART loops found
		On (steady)	A fault was detected and multiplexer operation has halted
HOST	yellow	Off	No communication on the channel
		Short flash (0.25 sec)	Correctly framed message received by the multiplexer
		Long flash (1 sec)	Response transmitted—this is re-triggerable so repeated transmissions will leave the indicator permanently on
HART	yellow	Off	No communication on the channel
		Short flash (0.25 sec)	Message transmitted
		Long flash (1 sec)	Response transmitted—this is re-triggerable so repeated transmissions will leave the indicator permanently on

### 6.3 Routine maintenance

It is advisable to check the general condition of the installation occasionally to make sure that no damage or deterioration has occurred. The following should be checked at least once every two years (more frequently for particularly harsh environments):

1. Modules are of the types specified in the relevant documentation and are mounted in the correct positions on the associated backplanes.
2. Modules and hazardous area connectors are correctly and legibly tagged; that the connectors are plugged into the matching modules and that the tag details given comply with the relevant documentation.
3. Modules and hazardous area connectors are securely plugged into their matching sockets.
4. All connections to the backplane, and to the hazardous area connectors, are properly made.
5. Connecting cables to backplanes and to the hazardous area connectors are of the specified type and rating. They should be correctly routed and segregated and not frayed or otherwise damaged.
6. Cable screens are properly earthed.

**Caution:** It is strongly recommended that users only undertake the tests and routine maintenance described in sections 6.2 and 6.3.

If an MTL4500 module is judged faulty, repairs or modifications **MUST NOT** be made as these may affect the intrinsic safety of the module. For repair or replacement, any faulty units or backplanes should be returned to MTL or the representative from which they were purchased.

## 7 SOFTWARE CONNECTIVITY

### 7.1 Introduction

The MTL HART system provides access from a PC to the HART field devices for configuration, diagnostics and the monitoring of device performance. HART devices may be selected for regular status monitoring, and an alert issued if the status changes. An internal alarm log is also maintained which may be accessed through the Instrument Management Software (IMS) package- see Appendix B for further details.

In addition, MTL's HART connection system supports dedicated software packages for valve positioners to optimise valve maintenance schedules.

### 7.2 Communication modes

Many of the IMS packages available are based upon the use of Device Driver (DD) files or upon FDT Technology as a frame for the various communication elements.

MTL provides the software driver files to support each of these approaches.

The example below shows the integration of an MTL4850 HART Multiplexer within the Emerson AMS package applying the MTL4850 DD file.

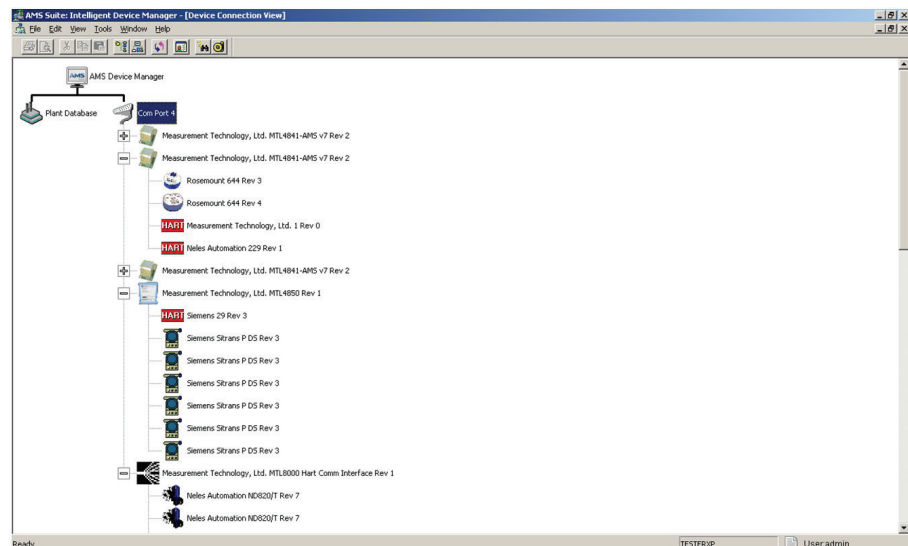

This second example shows the deployment of the MTL Comms DTM (Device Type Manager) within the Fieldcare package from Endress+Hauser and Metso that uses FDT Technology.

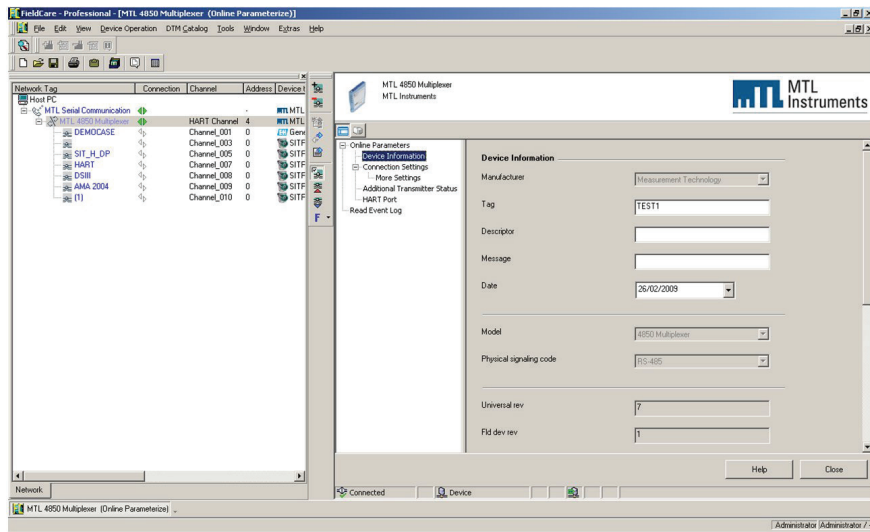

The MTL Comms DTM enables an MTL4850/54 system to pass HART data to any IMS that utilises the FDT/DTM concept.

The DD and DTM files are free of charge and can be downloaded from the MTL website at: [www.mtl-inst.com/product/hart\\_software](http://www.mtl-inst.com/product/hart_software)

### 7.3 Software setup

Having connected the MTL4850/54 system, as described in this manual, set up the software as described in the software user's manual.

*Acknowledgements:*

*Windows is a trademark of Microsoft Corporation*

*HART is a registered trademark of HART Communication Foundation*

## **8 APPLICATIONS INVOLVING ZONE 2 HAZARDOUS AREAS**

**Important: see the Declaration of Conformity on page ii at the front of this manual for important additional information regarding the use of these products in countries governed by the ATEX Directive. The following information is in accordance with the Essential Health and Safety Requirements (Annex II) of the EU Directive 94/9/EC [the ATEX Directive – safety of apparatus] and is provided for those locations where the ATEX Directive is applicable.**

### **8.1 General**

a) This equipment must only be installed, operated and maintained by competent personnel. Such personnel shall have undergone training, which included instruction on the various types of protection and installation practices, the relevant rules and regulations, and on the general principles of area classification. Appropriate refresher training shall be undertaken on a regular basis. [See clause 4.2 of EN 60079-17].

b) This equipment has been designed to provide protection against all the relevant additional hazards referred to in Annex II of the directive, such as those in clause 1.2.7.

c) The MTL4850/MTL4854 and associated products mentioned in the DoC are certified as meeting the requirements of IEC/EN 60079-15 for Zone 2 applications and the European Community permits Category 3G equipment, such as these items from the MTL4850 Series, to be installed in Zone 2 flammable atmospheres provided it meets the requirements of the ATEX Directive.

### **8.2 Installation**

a) The installation must comply with the appropriate European, national and local regulations, which may include reference to the code of practice IEC/EN 60079-14. In addition, particular industries or end users may have specific requirements relating to the safety of their installations and these requirements should also be met. For the majority of installations the Directive 1999/92/EC [the ATEX Directive- safety of installations] is also applicable.

b) This apparatus may be installed in a safe area and also in a Zone 2 location providing that the relevant installation conditions are met, as given in the Special Conditions here below:

#### **Special conditions of Safe Use for Zone 2 applications**

- 1) The equipment must be installed in an area of not more than pollution degree 2 in accordance with IEC/EN 60664-1, and in an enclosure that provides a minimum degree of protection of at least IP54 and complies with the relevant requirements of IEC/EN 60079-0 and IEC/EN 60079-15.
- 2) External connections to the equipment and internal connections between the modules forming the equipment must not be inserted or removed unless either the area in which the equipment is installed is known to be non-hazardous, or the circuits connected have been de-energised.
- 3) The certified equipment to which the HCU16-xxx is connected must be fitted with transient protection devices meeting the requirements of clause 13 of IEC/EN 60079-15.

### **8.3 Inspection and maintenance**

a) Inspection and maintenance should be carried out in accordance with European, national and local regulations which may refer to the standard IEC/EN 60079-17. In addition specific industries or end users may have specific requirements which should also be met.

b) Access to the internal circuitry must not be made during operation.



## 8.4 Repair

This product cannot be repaired by the user and must be replaced with an equivalent certified product.

## 8.5 Marking

Each device is marked in compliance with the directive and relevant standards.

Equipment Name:	MTL4850 & MTL4854 HART Multiplexer System
IECEX Certificate No:	IECEX BAS 14.0125X
Certification Code	Ex nA IIC T4 Gc (-40°C ≤ T <sub>a</sub> ≤ +70°C)

Equipment Name:	HCU16-xxx HART Connection Unit
IECEX Certificate No:	IECEX BAS 14.0126X
Certification Code	Ex nA IIC T4 Gc (-40°C ≤ T <sub>a</sub> ≤ +70°C)

As shown in the Declaration of Conformity on page ii, these products are included in the ATEX Cat3 certificate number MTL08ATEX4850X

## 9 APPENDIX A - TYPICAL COMPATIBLE SYSTEMS

MTL offer a range of backplanes for mounting MTL4500 Series IS isolators that are customized to the requirements of the particular control or shutdown system. Many of these custom boards for the analogue I/O signals include a connector for the ribbon cable connection to an HMP-HM64. Typical system examples are:

### Emerson

DeltaV and DeltaV SIS systems

### HIMA

HiMax

### Honeywell

Experion C300, Safety Manager, Process Manager I/O systems

### Invensys

Foxboro FBM systems, Triconex Tricon & Trident systems

### Siemens

ET200M

### Yokogawa

Centum R3, Prosafe RS systems

Contact MTL with details of your specific requirements.

## 10 APPENDIX B - ALARM EVENT LOG

The multiplexer maintains a log of alarm events that may read using the Instrument Management Software. The types of event that might appear can be grouped into the following categories:

- General information
- Multiplexer internal parameters or values
- Diagnostic errors causing reset

The possible event log messages are listed below by category, and the meaning or appropriate action is supplied beside them.

General logs	Meaning or required action
!Alarm generated by HART test command 242	MTL diagnostic test activated
!No storage space for transmitter	Memory full of field device data
!Found a pre Rev 5 HART transmitter	Check manufacturer for update
!Other master detected on loop	Secondary master present
!Alarm Clear input used to reset alarms	
Download of bootloader started	Firmware update in progress
Bootloader download complete, module will restart	Firmware update completed
Debug mode. No CRC installed in flash memory	
Reset due to Watchdog or Brownout	See list of causes below
Module Powered Up	
Module failed watchdog test	Return to MTL if alarm persists.
Warm start - Event Log or status corrupt	
Unknown reason for module reset	

Logs followed by a value:	Meaning or required action
!Duplicate Transmitter Unique Id. ID used on loop	Check manufacturer for update
!+12V Supply out of range	Check power supply to multiplexer is within specification. Return to MTL if alarm persists.
!-12V Supply out of range	Return to MTL if alarm persists.
!VBias out of range	Return to MTL if alarm persists.
!VLeak out of range	Return to MTL if alarm persists.
Power up scan complete - Transmitters found =	Number, 0-32

Logs followed by 2 values:	Meaning or required action
!VH signal out of range	Check power supply to multiplexer is within specification. Return to MTL if alarm persists.

Log messages following an error that caused the module to reset	Meaning or required action
!CRC error in RAM copy of serial number	Return to MTL if alarm persists.
!CRC error in RAM image of configuration parameters	Return to MTL if alarm persists.
!An internal watchdog reset occurred	Return to MTL if alarm persists.
!A clock monitor reset occurred	Return to MTL if alarm persists.
!Module restarted due to failure in Startup Ram test	Return to MTL if alarm persists.
!Background RAM word test failed	Return to MTL if alarm persists.
!Background Ram byte test failed	Return to MTL if alarm persists.
!Background Ram block test failed	Return to MTL if alarm persists.
!Cold start flash test failed	Return to MTL if alarm persists.
!Incremental flash test failed	Return to MTL if alarm persists.
!Incremental flash test switch variable corrupt	Return to MTL if alarm persists.
!Illegal instruction trap did not execute	Return to MTL if alarm persists.
!Stack overflowed	Return to MTL if alarm persists.
!Stack underflowed	Return to MTL if alarm persists.

!Background diagnostics not running	Return to MTL if alarm persists.
!RAM test not running	Return to MTL if alarm persists.
!Bad call to diagnostic monitor	Return to MTL if alarm persists.
!RAM test copy address corrupted	Return to MTL if alarm persists.
!RAM corruption of TQ data in diag	Return to MTL if alarm persists.
!Incremental CPU test failed	Return to MTL if alarm persists.
Diagnostic session counter corrupted	Return to MTL if alarm persists.
!EEPROM Group1 CRC error	Return to MTL if alarm persists.
!EEPROM Group2 CRC error	Return to MTL if alarm persists.
!RAM corruption in TQ data in EHS	Return to MTL if alarm persists.
!An unused interrupt has occurred	Return to MTL if alarm persists.
!PLL out of lock	Return to MTL if alarm persists.
!An illegal instruction has been encountered	Return to MTL if alarm persists.
!Cold start CPU test failed	Return to MTL if alarm persists.
!Bad call to program monitor	Return to MTL if alarm persists.
!Stack pointer corrupted	Return to MTL if alarm persists.
!Sequence error: Main initialisation	Return to MTL if alarm persists.
!Sequence error: Main startup	Return to MTL if alarm persists.
!Sequence error: First Field I/O	Return to MTL if alarm persists.
!Sequence error: Timer Queue	Return to MTL if alarm persists.
!Sequence error: Second Field I/O	Return to MTL if alarm persists.
!Sequence error: Event handler	Return to MTL if alarm persists.
!Sequence error: Diagnostic processing	Return to MTL if alarm persists.
!Module state corrupted	Return to MTL if alarm persists.
!RAM corruption of TQ data in main	Return to MTL if alarm persists.
!The 1ms timer ISR executed late	Return to MTL if alarm persists.
!The 1ms timer ISR executed early	Return to MTL if alarm persists.
!Program monitor failed to report	Return to MTL if alarm persists.
!Diagnostic monitor failed to report	Return to MTL if alarm persists.
!Cancelled timer can't be found	Return to MTL if alarm persists.
!TQ Run out of sequence	Return to MTL if alarm persists.

Single or occasional occurrence of these events may be due to noise or interruptions of the power supply, but multiple or frequent events might indicate problems with the installation, or with the module, in which case it should be returned to MTL for investigation.



#### AUSTRALIA

MTL Instruments Pty Ltd,  
205-209 Woodpark Road, Smithfield,  
New South Wales 2164, Australia  
Tel: + 61 1300 308 374 Fax: + 61 1300 308 463  
E-mail: mtl-salesanz@eaton.com

#### BeNeLux

MTL Instruments BV  
Terheijdenseweg 465, 4825 BK Breda  
The Netherlands  
Tel: + 31 (0) 76 7505360 Fax: +31 (0) 76 7505370  
E-mail: mtl.benelux@eaton.com

#### CHINA

Cooper Electric (Shanghai) Co. Ltd  
955 Shengli Road, Heqing Industrial Park  
Pudong New Area, Shanghai 201201  
Tel: + 86 2128993817 Fax: + 86 2128993992  
E-mail: mtl-cn@eaton.com

#### FRANCE

MTL Instruments sarl,  
7 rue des Rosieristes, 69410 Champagne au Mont d'Or  
France  
Tel: + 33 (0)4 37 46 16 70 Fax: +33 (0)4 37 46 17 20  
E-mail: mtlfrance@eaton.com

#### GERMANY

MTL Instruments GmbH,  
Heinrich-Hertz-Str. 12, 50170 Kerpen, Germany  
Tel: + 49 (0)22 73 98 12-0 Fax: + 49 (0)22 73 98 12-2 00  
E-mail: mtlgmbh@eaton.com

#### INDIA

MTL India,  
No.36, Nehru Street, Off Old Mahabalipuram Road  
Sholinganallur, Chennai- 600 119, India  
Tel: + 91 (0) 44 24501660 /24501857 Fax: + 91 (0) 44 24501463  
E-mail: mtlindiasales@eaton.com

#### ITALY

MTL Italia srl,  
Via A. Meucci, 10, I-20094 Corsico (MI), Italy  
Tel: + 39 (0)2 61802011 Fax: + 39 (0)2 61294560  
E-mail: chminfo@eaton.com

#### JAPAN

Cooper Crouse-Hinds Japan KK,  
MT Building 3F, 2-7-5 Shiba Daimon, Minato-ku,  
Tokyo, Japan 105-0012  
Tel: + 81 (0)3 6430 3128 Fax: + 81 (0)3 6430 3129  
E-mail: mtl-jp@eaton.com

#### NORWAY

Norex AS  
Fekjan 7c, Postboks 147,  
N-1378 Nesbru, Norway  
Tel: + 47 66 77 43 80 Fax: + 47 66 84 55 33  
E-mail: info@norex.no

#### SINGAPORE

Cooper Crouse-Hinds Pte Ltd  
No 2 Serangoon North Avenue 5, #06-01 Fu Yu Building  
Singapore 554911  
Tel: + 65 6 645 9888 Fax: + 65 6 487 7997  
E-mail: sales.mtlsing@eaton.com

#### SOUTH KOREA

Cooper Crouse-Hinds Korea  
12F, Vision Tower, 707-2 Yeoksam-Dong Gangnam-Gu,  
Seoul 135-080, South Korea.  
Tel: + 82 2 538 3481 Fax: + 82 2 538 3505  
E-mail: mtl-korea@eaton.com

#### UNITED ARAB EMIRATES

Cooper Industries/Eaton Corporation  
Office 205/206, 2nd Floor SJ Towers, off. Old Airport Road,  
Abu Dhabi, United Arab Emirates  
Tel: + 971 2 44 66 840 Fax: + 971 2 44 66 841  
E-mail: mtlgulf@eaton.com

#### UNITED KINGDOM

Measurement Technology Limited,  
Great Marlings, Butterfield, Luton  
Beds LU2 8DL  
Tel: + 44 (0)1582 723633 Fax: + 44 (0)1582 422283  
E-mail: mtlenquiry@eaton.com

#### AMERICAS

Cooper Crouse-Hinds MTL Inc.  
3413 N. Sam Houston Parkway W.  
Suite 210, Houston TX 77086, USA  
Tel: + 1 281-571-8065 Fax: + 1 281-571-8069  
E-mail: mtl-us-info@eaton.com