

Process JBs

Process junction boxes for fieldbus installations

- **Easy to install & maintain**
- **Standard proven designs reduce project costs**
- **Superb corrosion resistance**
- **Wide choice of cable gland types**
- **All glanding holes are located in the base of the enclosure**
- **Generous space for cable terminations**
- **Strong, high impact resistance, durable**



Eaton's MTL Process JBs are designed for mounting Megablock fieldbus wiring components, terminators, F30 Ex ic adaptor, 9320 spur connections and surge protection devices, in order to meet the exacting requirements of process industry customers.

MTL wiring components are established as the industry standard for fieldbus device connections and are combined with Crouse-Hinds junction box and cable glands in the Process JB product range.

Process JBs make it easy to install and maintain the fieldbus system. For example, a minimum of 75mm (3") of clearance is provided for fieldbus cable connections. This ensures that the correct bend radius is maintained when connecting to the full range of MTL wiring components.

They are available in a choice of materials that provide strength, durability and corrosion resistance to many chemicals and their vapours. The FCS-9000 enclosures are manufactured from 316 stainless steel to provide the highest level of corrosion protection. The FCS-8000 enclosures are manufactured from carbon-loaded, polyester which combines strength with the highest level of corrosion resistance.

A wide choice of glands is available, ready fitted to the junction box: stainless steel, nickel-plated brass and plastic, enabling a high quality seal with standard or wire-armoured cables. All glanding is in the base of the enclosure with a minimum of 75mm of clearance between the base of the enclosure and other components. This makes glanding much easier, especially when terminating armoured cable.

Significant cost savings can be made on a fieldbus project by selecting standard, and proven, fieldbus junction box designs. It eliminates the need for custom designs when choosing junction boxes for fieldbus applications and saves the cost of managing the specification and the eventual procurement of the junction boxes.

To select the Process JB appropriate to your application; first decide on the enclosure material, based upon site conditions, required strength, durability and economics; this will define which series you require.

Next, determine the number of fieldbus device connections, and hence the number of spur connections required in the junction box. This will also define which Megablocks (and maybe terminators) are required. Use the application examples to help you.

Identify any additional items that will need to be housed in the enclosure, e.g. terminals for terminating spare cables, Ex ic adaptor, additional terminators, etc. Calculate how much DIN rail they will require. Add this to length of the Megablock(s) and choose an enclosure with sufficient rail length.

Finally, decide on gland type. Is the cable armoured? Does the environment require stainless steel or nickel plated brass glands, or will plastic be sufficient? See application example tables and ordering information for details on how to fully specify the enclosure in your order.

FCS-8000 range

Junction boxes

The FCS-8000 Series carbon loaded polyester enclosures provide the highest levels of corrosion resistance for the harshest process environments.

The FCS-85xx Process JBs are suitable for Zone 2 and Zone 1 intrinsically safe (Ex i) and increased safety applications. The controlled surface resistance eliminates the risk of static buildup. The junction boxes are available pre-drilled for one segment: having trunk-in, trunk-out and 4 spur connections; or a trunk-in and 10 or 12 spur connections; or two segments having a trunk-in and 20 or 24 spur connections. Two-pair multicore trunk cable may be used when only a single trunk gland is available.

A wide choice of glands, including stainless steel, nickel-plated brass and plastic, enables a high quality seal to be achieved with either standard or wire-armoured cables.

The mounting screws are insulated by the case material and are located outside of the lid seal. A 10mm earth stud and a breather are included as standard.

An adhesive backed, Traffolyte tag label is supplied loose or can be engraved with the tag number and fitted, if details are supplied when ordering.



SPECIFICATION

GENERAL

Materials

Carbon-loaded, glass-fibre reinforced polyester, halogen-free, surface resistance <math> < 10^9 \Omega </math> to EN 50014

Stainless steel lid screws, silicone lid seal

DIN rail

FCS-8504, FCS-8510, FCS-8512: - one (1) DIN rail

FCS-8520, FCS-8524: - two (2) DIN rails

DIN rail to EN 50022 35 x 7.5 'T' section, mounted vertically

Each rail fitted with two end stops

Breather plug

Provided

External earth connection

M10 threaded stud

Tag label

Traffolyte, adhesive backed - white background - black text

ENVIRONMENTAL

Operating Temperature

-45°C to +70°C - Steel & nickel plated brass glands

-30°C to +70°C - Plastic glands

Storage Temperature

-45°C to +85°C

Relative Humidity % RH (non-condensing)

5 to 95%

IP rating

IP66 to EN 60529

Impact resistance

7 Nm to EN 50014

Location of Process JB

Safe area, Zone 2, IIC T4 hazardous area or Zone 1, IIC T4 hazardous area for intrinsically safe fieldbus segment.

Note: If used in a hazardous area, the contents must be suitably certified/approved.

APPLICATION EXAMPLES

Model	Max. glands	DIN rail length mm	Megablocks /trunk	No of trunks	Spurs/ trunk	Trunk in	Trunk out	Total spurs	-ZZ* value	Unused DIN rail length mm
Single trunk applications										
FCS-8504	6	157	2 way	1	2	1	1	2	0	102
			4 way	1	4	1	1	4	0	71
			4 way(T)	1	4	1	-	4	0	71
FCS-8510	11	157	4 way + 2 way	1	6	1	1	6	0	21
			8 way	1	8	1	1	8	0	21
			8 way(T)	1	8	1	-	8	0	21
			10 way(T)	1	10	1	-	10	10	-
FCS-8512	13	303	12 way (T)	1	12	1	-	12	12	109
			Ex ic + 4 way (T)	1	4	1	-	4	0	127
			Ex ic + 8 way (T)	1	8	1	-	8	0	75
			Ex ic + 12 way (T)	1	12	1	-	12	12	24
FCS-8520	21	2 x 302	8 way + 8 way(T)	1	16	1	-	16	16	2 x 166
Double trunk applications										
FCS-8520	21	2 x 302	2 x 8 way(T)	2	8	1 (2-pair multicore)	-	16	16	2 x 166
			2 x 10 way(T)	2	10	1 (2-pair multicore)	-	20	20	2 x 145
FCS-8524	25	2 x 302	2 x 12 way(T)	2	12	1 (2-pair multicore)	-	24	24	2 x 109
			2 x Ex ic 12 way(T)	2	12	1 (2-pair multicore)	-	24	24	2 x 13

(T) = Megablock with integral terminator * see ordering information

ENCLOSURE AND MOUNTING DETAILS

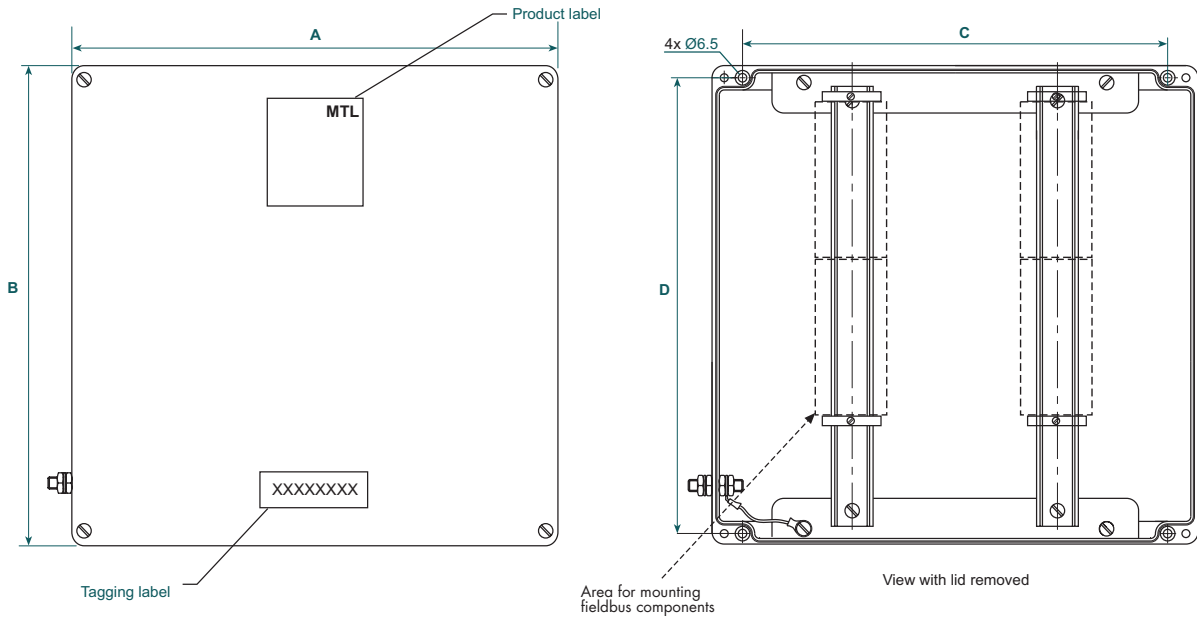

	A	B	C	D	E	F	Weight
FCS-8504	251	256.5	200.5	236	121	N/A	3.5 - 4.0kg
FCS-8510	251	256.5	200.5	236	121	N/A	3.5 - 4.5kg
FCS-8512	250.5	402	201	381.5	120	N/A	5.0 - 6.2kg
FCS-8520	406	401	356	381.5	120	172	6.0 - 7.9kg
FCS-8524	406	401	356	381.5	120	172	6.0 - 8.2kg

GLANDING ARRANGEMENTS

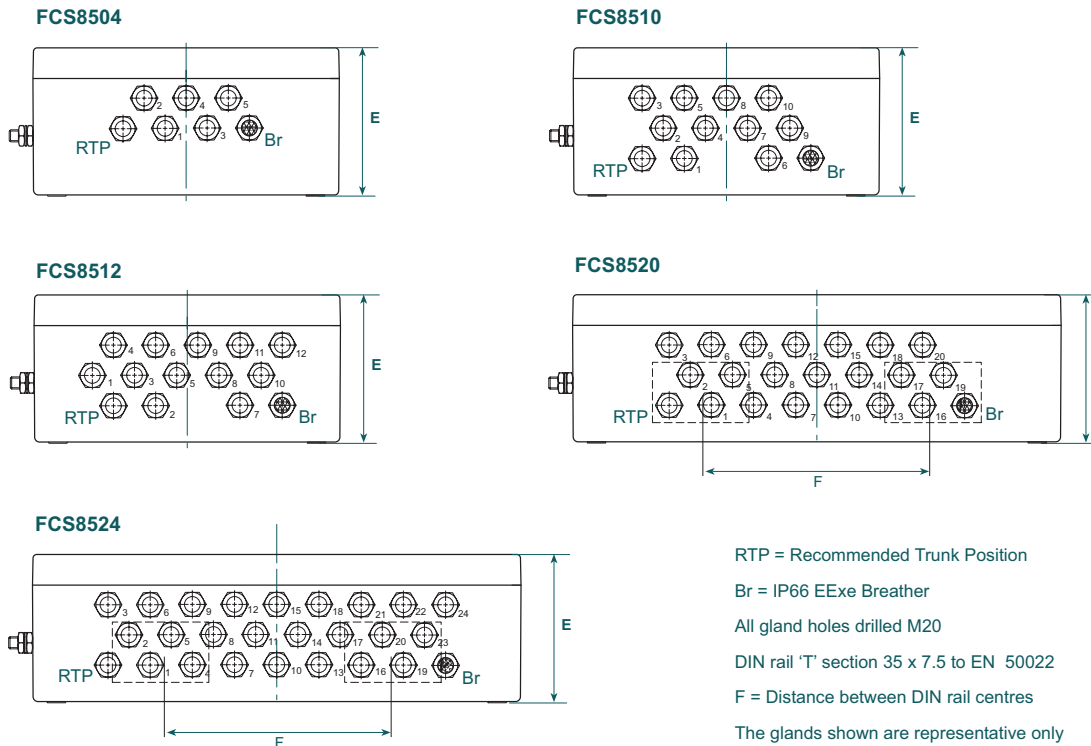

RTP = Recommended Trunk Position
 Br = IP66 EExe Breather
 All gland holes drilled M20
 DIN rail 'T' section 35 x 7.5 to EN 50022
 F = Distance between DIN rail centres
 The glands shown are representative only

FCS-9000 range

Junction boxes

The FCS-9000 Series enclosures are manufactured from polished 316 stainless steel to provide the highest levels of corrosion resistance for the harshest process environments.

The FCS-95xx Process JBs are suitable for Zone 2 and Zone 1 intrinsically safe (Ex i) and increased safety applications.

The junction boxes are available pre-drilled for one segment: having trunk-in, trunk-out and 4 spur connections; or a trunk-in and 10 or 12 spur connections; or two segments having a trunk-in and 24 spur connections. Two-pair multicore trunk cable may be used when only a single trunk gland is available.

The wide choice of glands, including stainless steel, nickel-plated brass and plastic, enables a high quality seal with standard or wire armoured cables.

The box incorporates a rain channel that prevents standing water from damaging the one-piece seal; diverting it away from the contents when the door is opened. A 10mm earth stud and a breather are also included as standard.

An adhesive backed, Traffolyte tag label is supplied loose or can be engraved with the tag number and fitted, if details are supplied when ordering.



SPECIFICATION

GENERAL

Materials

Electrochemically polished 316 Stainless Steel
Silicon gasket

DIN rail

FCS-9504, FCS-9510, FCS-9512: - one (1) DIN rail
FCS-9524: - two (2) DIN rails
DIN rail to EN 50022 35 x 7.5 'T' section, mounted vertically
Each rail fitted with two end stops

Breather plug

Provided

External earth connection

M10 threaded stud

Tag label

Traffolyte, adhesive backed - white background - black text

Other

Hinged lid

ENVIRONMENTAL

Operating Temperature

-40°C to +70°C - Steel & nickel plated brass glands
-30°C to +70°C - Plastic glands

Storage Temperature

-45°C to +85°C

Relative Humidity % RH (non-condensing)

5 to 95%

IP rating

IP66 to EN 60529

Impact resistance

7 Nm to IEC 60079-7

Location of Process JB

Safe area, Zone 2, IIC T4 hazardous area or Zone 1, IIC T4 hazardous area for intrinsically safe fieldbus segment.

Note: If used in a hazardous area, the contents must be suitably certified/approved.

APPLICATION EXAMPLES

Model	Max. glands	DIN rail length mm	Megablocks /trunk	No of trunks	Spurs/trunk	Trunk in	Trunk out	Total spurs	-ZZ* value	Unused DIN rail length mm
Single trunk applications										
FCS-9504	6	166	2 way	1	2	1	1	2	0	111
			4 way	1	4	1	1	4	0	80
			4 way(T)	1	4	1	-	4	0	80
FCS-9510	11	166	4 way + 2 way	1	6	1	1	6	0	30
			8 way	1	8	1	1	8	0	30
			8 way(T)	1	8	1	1	8	0	30
			10 way(T)	1	10	1	-	10	10	-
FCS-9512	13	212	12 way (T)	1	12	1	-	12	12	-
			Ex ic + 4 way (T)	1	4	1	-	4	4	12
FCS-9542	13		Ex ic + 8 way (T)	1	8	1	-	12	12	-
			Ex ic + 12 way (T)	1	12	1	-	12	12	-
FCS-9524	25	2 x 286	8 way + 8 way(T)	1	16	1	-	16	16	2 x 150
Double trunk applications										
FCS-9524	25	2 x 286	2 x 8 way(T)	2	8	1 (2-pair multicore)	-	16	16	2 x 150
			2 x 10 way(T)	2	10	1 (2-pair multicore)	-	20	20	2 x 129
			2 x 12 way(T)	2	12	1 (2-pair multicore)	-	24	24	2 x 93
			2 x Ex ic 12 way(T)	2	12	1 (2-pair multicore)	-	24	24	2 x 8

(T) = Megablock with integral terminator

* see ordering information

ENCLOSURE AND MOUNTING DETAILS

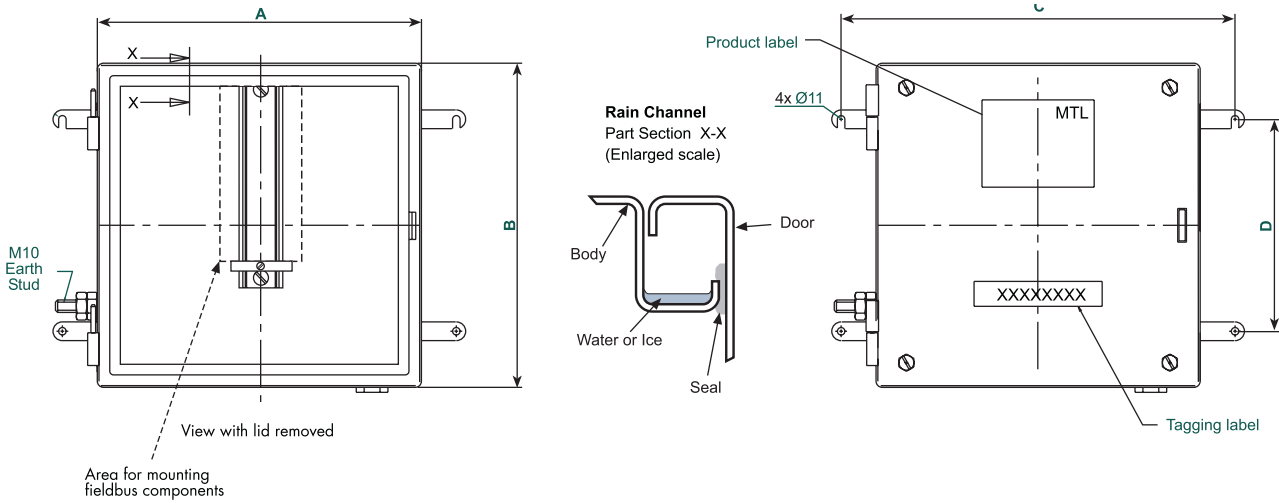

	A	B	C	D	E	F	Weight
FCS-9504	260	260	316	170	160	N/A	6.0 - 6.5kg
FCS-9510	260	260	316	170	160	N/A	6.0 - 7.0kg
FCS-9512	306	306	361	203	160	N/A	7.0 - 8.2kg
FCS-9524	450	380	506	250	205	185	10.0 - 12.2kg
FCS-9542	260	380	316		160	N/A	

GLANDING ARRANGEMENTS

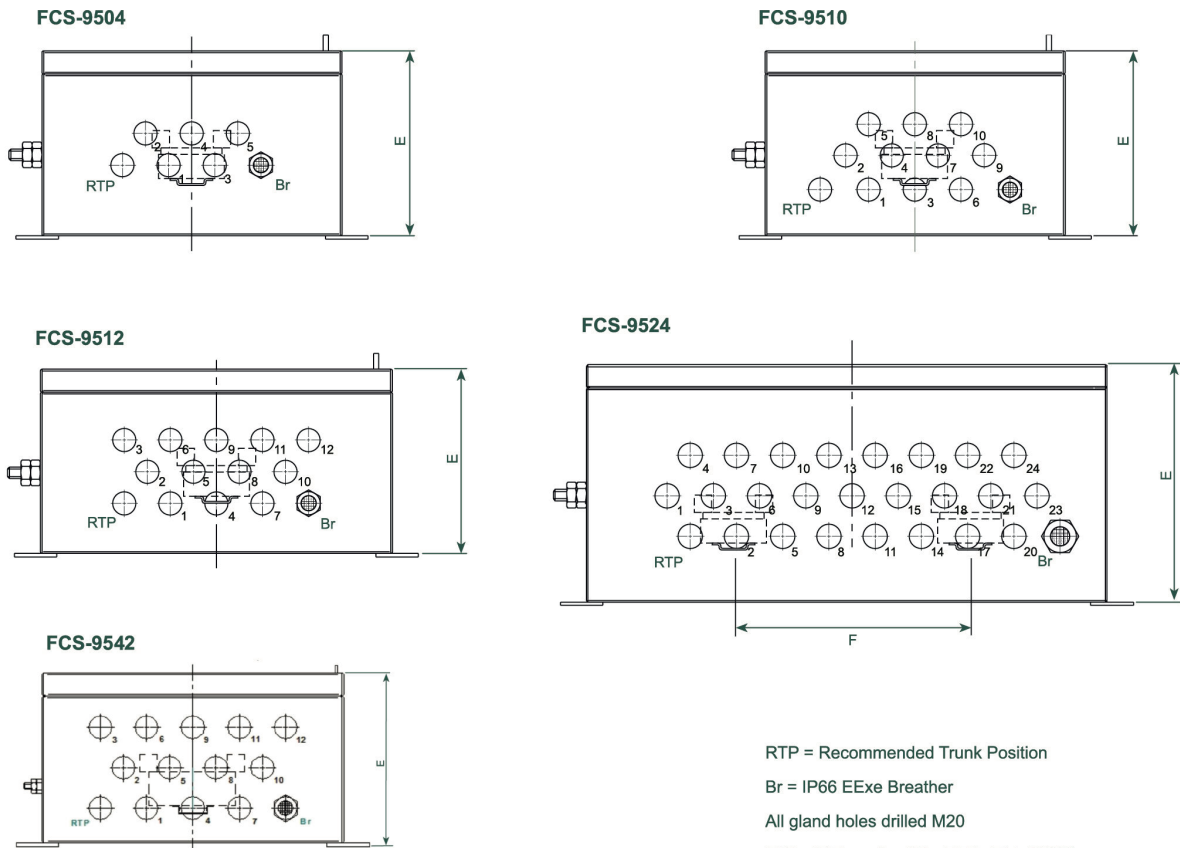

RTP = Recommended Trunk Position
 Br = IP66 EExe Breather
 All gland holes drilled M20
 DIN rail 'T' section 35 x 7.5 to EN 50022
 F = Distance between DIN rail centres

Process JBs

November 2015

APPROVALS

Region		Europe	International	N America
Authority		PTB	PTB	UL
Standard		EN 60079-0:2012 EN 60079-7:2007 EN 60079-31:2009	IEC 60079-0:2011 IEC 60079-11:2011 IEC 60079-31:2013 IEC 60079-7:2006-07	
Approved for		⊕ II 2 G Ex e IIC Gb ⊕ II 2 D Ex tb IIIC Db IP66	Ex e IIC Gb Ex tb IIIC Db	Nema 4X
MTL Part No.	Bartec Enclosure Part Number	Certificate Numbers		
FCS-8504	07-5185-2552/5012	PTB 08 ATEX 1062 U	IECEX PTB 09.0008U	E188224
FCS-8510	07-5185-2552/5012	PTB 08 ATEX 1062 U	IECEX PTB 09.0008U	E188224
FCS-8512	07-5185-4002/5012	PTB 08 ATEX 1062 U	IECEX PTB 09.0008U	E188224
FCS-8520	07-5185-4004/0512	PTB 08 ATEX 1062 U	IECEX PTB 09.0008U	E188224
FCS-8524	07-5185-4004/0512	PTB 08 ATEX 1062 U	IECEX PTB 09.0008U	E188224

Region		Europe	International	N America
Authority		Dekra	Dekra	UL
Standard		EN 60079-0:2012 EN60079-7:2007 EN60079-31:2009	IEC 60079-0:2011 IEC 60079-7:2006-07 IEC 60079-31:2008	UL508A Industrial Control Panels CAN/CSA C22.2 No. 14-13 Industrial Control Panels
Approved for		⊕ II 2 G Ex e IIC Gb ⊕ II 2 D Ex fb IIIC Db	Ex e IIC Gb Ex tb IIIC Db	
MTL Part No.	Crouse Hinds Enclosure Part Number	Certificate Numbers		
FCS-9504	N-TB262616	BVS 13 ATEX E 014 U	IECEX BVS 13.0026U	20140108-E115376
FCS-9510	N-TB262616	BVS 13 ATEX E 014 U	IECEX BVS 13.0026U	20140108-E115376
FCS-9512	N-TB303016	BVS 13 ATEX E 014 U	IECEX BVS 13.0026U	20140108-E115376
FCS-9524	N-TB384520	BVS 13 ATEX E 014 U	IECEX BVS 13.0026U	20140108-E115376
FCS-9542	N-TB382616	BVS 13 ATEX E 014 U	IECEX BVS 13.0026U	20140108-E115376

GLAND OPTION DETAILS

Option	Description	Gland model no.	Cable size mm	Socket size mm	Temp. range	Certification
-A20	Nickel plated brass gland, for steel wired armoured cable M20 Ex d/e double silicone seal	Capri ADE 5F-CAP856695V1	10.0 – 16.0 outer diam. 7.0 – 12.0 inner diam. 0.2 – 1.2 armour	24/24	-60°C to +140°C	IECEX INE 12.0025X INERIS 12ATEX0032X
-R20	Stainless Steel Gland, for Steel Wired Armoured Cable M20 Ex d/e double silicone sea	Capri ADE 5F-CAP856696V1	10.0 – 16.0 outer diam. 7.0 – 12.0 inner diam. 0.2 – 1.2 armour	24/24	-60°C to +140°C	
-C20	Nickel plated brass gland, for un-armoured cable M20, Ex e single silicone seal	Capri ADE 1F2-CAP806695V1	7.0 – 12.0 outer diam.	19/24	-60°C to +140°C	
-S20	Stainless Steel Gland, for un-armoured cable M20, Ex e single silicone seal	Capri ADE 1F2-CAP806696V1	7.0 – 12.0 outer diam.	19/24	-60°C to +140°C	
-P20	Plastic gland, for un-armoured cable M20, Ex e single silicone seal	Jacob GmbH-50.620 PASWLEXSI	5.5 – 13.0 outer diam.	24/24	-55°C to +70°C	IECEX PTB 05.0004X PTB 99 ATEX 3128 X

ORDERING INFORMATION

Part No
FCS-X5XX-YYY-ZZ

	FCS-85XX	FCS-95XX
4 spur outlets + trunk-in and trunk-out	FCS-8504	FCS-9504
10 spur outlets + trunk-in	FCS-8510	FCS-9510
12 spur outlets + trunk-in	FCS-8512	FCS-9512
12 spur outlets + Ex ic adapter + trunk-in	FCS-8512	FCS-9542
20 spur outlets + trunk-in	FCS-8520	
24 spur outlets + trunk-in	FCS-8524	FCS-9524

- YYY = trunk & spur glanding
- 020 = Predrilled for M20 glands - none fitted
- X20 = Predrilled, with M20 brass blanking plugs
- Y20 = Predrilled, with M20 plastic blanking plugs
- A20 = Nickel-plated brass M20 glands for wire-armoured cable
- R20 = Stainless Steel M20 glands for wire-armoured cable
- S20 = Stainless Steel M20 glands
- C20 = Nickel-plated brass M20 glands
- P20 = Plastic M20 glands

-ZZ = number of spur outlet glands to be fitted

A gland of the specified type is **always supplied** and fitted for the trunk-in. Any remaining holes are fitted with blanking plugs of the same material as the glands. *If this number is not specified, glands will be fitted to all outlets (including the trunk-out, if applicable).*

Example part number

FCS-9504-A20-04

An FCS-9504 junction box having 4 spur outlets, 1 trunk-in and 1 trunk-out. Supplied with nickel-plated brass M20 glands for wire-armoured cable fitted on 4 spur outlets +1 trunk-in. The trunk-out has a nickel-plated blanking plug fitted.



Measurement Technology Limited,
 Great Marlings, Butterfield, Luton
 Beds, LU2 8DL, UK.
 Tel: + 44 (0)1582 723633 Fax: + 44 (0)1582 422283
 E-mail: mtlenquiry@eaton.com
www.mtl-inst.com

© 2015 MTL
 All Rights Reserved
 Publication No. EPS PJB Rev D 031115
 November 2015

EUROPE (EMEA):
 +44 (0)1582 723633
mtlenquiry@eaton.com

THE AMERICAS:
 +1 800 835 7075
mtl-us-info@eaton.com

ASIA-PACIFIC:
 +65 6 645 9888
sales.mtlsing@eaton.com

The given data is only intended as a product description and should not be regarded as a legal warranty of properties or guarantee. In the interest of further technical developments, we reserve the right to make design changes.