

## Tofino™ 9202-ETS range

### Key Features:

- Improved system reliability and stability
- Reduced down time and production losses
- Lower maintenance costs
- Simplified regulatory and security standard compliance
- Plug-n-Protect installation requires no preconfiguration, no network changes, and no disruption to the control system
- Simple configuration over the network using the free Tofino Configurator software
- Unique 'Test' mode allows firewall testing with no risk to your operation
- Pre-installed Firewall, Event Logger and NetConnect Loadable Security Modules (LSM)
- Compatible with all DCS, PLC, SCADA, networking, and software products
- Rugged hardware design for years of reliable service
- Secure networks with security zones as per NERC, ANSI/ISA, and IEC standards
- Protect connections to partners networks and wireless networks
- Improve SCADA and process control network reliability and performance

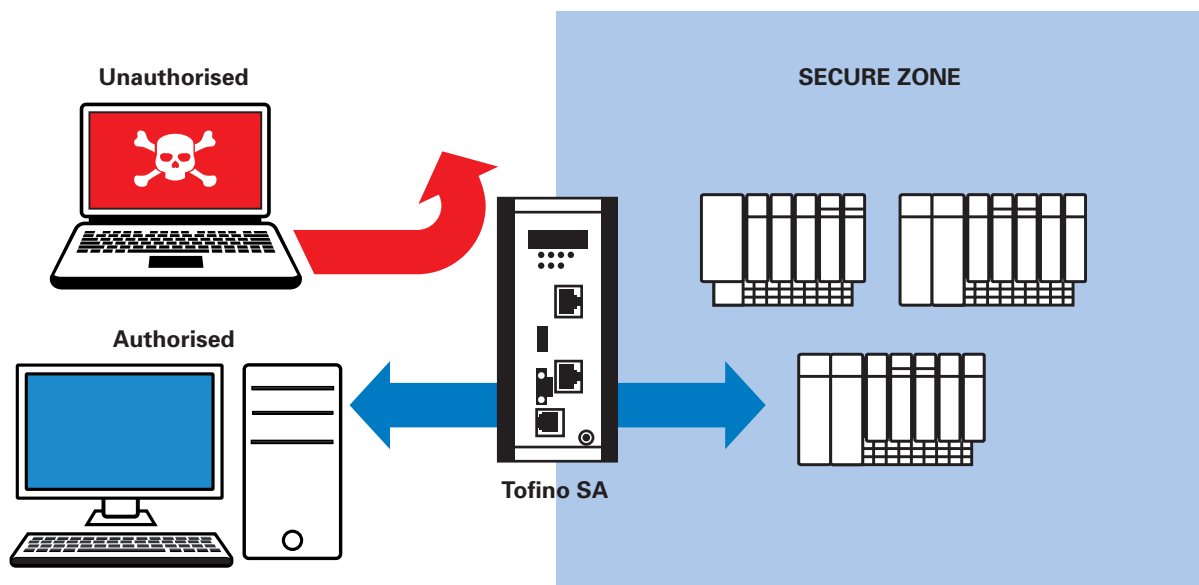

## SPECIFICATIONS

### Ethernet Interfaces

2 x FE (100BASE-TX)

### Additional Interfaces

#### USB Interface

1 x USB socket to connect load/verify configuration

#### Digital Input

1 x plug-in terminal block, 2-pin

#### Signalling Contact

1 x max. 60 V DC or max. 30 V AC, SELV, max. 1A

### Network Size

#### Twisted Pair

(TP) 0 to 100 m

### Power Requirements

#### Operating Voltage

12 to 48 V DC, 24 V AC redundant power supply

#### Power Consumption

5 Watts

#### Power Supply/Signaling Contact

1 x plug-in terminal block, 6-pin

### Software

#### Management

MTL Tofino Configurator (TC) software

#### Loadable Security Modules (LSMs)

Basic LSMs (pre-installed): Firewall, Event Logger & NetConnect

Enforcer LSMs (to be ordered separately): Modbus TCP

Enforcer (9522-MBT), OPC Enforcer (9522-OPC) &

EtherNet/IP Enforcer (9522-EIP)

#### Diagnostics

LEDs (power, mode, fault, save/load, reset, link status), signal contact, syslog, configuration verify

#### Firewall

Stateful layer 2, 3 and 4 filtering with optional deep packet inspection for SCADA protocols (depending on purchased LSMs)

#### System Requirements

Windows XP, Windows 7 (32- and 64-bit), or Windows Server 2003, 2008, or 2008 SR2

#### Configuration method

##### Network

Tofino Configurator uses secure communications to configure the Tofino security appliance

##### Manual

Encrypted configuration files may be saved on a USB storage device and loaded into the Tofino security appliance via a secure USB port

### Operating modes

#### Test

All traffic allowed; alerts generated as per user rules

#### Operational

Traffic filtered and alerts generated as per user rules

#### Mode changes

Operating mode is controlled remotely from the free Tofino Configurator software

#### Audit log

Audit capabilities for tracking configuration changes

#### Security alerts

Simultaneous event logging to a remote syslog server and local nonvolatile memory for later download via network or USB storage device

### Ambient Conditions

#### Operating Temperature

-40°C to +70°C (IEC 60068-2-2 Dry Heat Test +85°C 16 hours)

#### Storage/Transport Temperature

-40°C to +85°C

#### Relative Humidity (non-condensing)

10% to 95%

#### Conformal Coating

Option available as 9202-ETS-CC

### Mechanical Construction

#### Dimensions (WxHxD)

60 x 145 x 125 mm

#### Weight

660 g

#### Protection Class

IP20

#### Mounting

DIN Rail 35 mm

### Approvals

#### Declaration of Conformity

CE, FCC, EN 61131, C-TICK, EN 60950

#### Safety of Industrial Control Equipment

cUL508

#### Hazardous Locations

ISA-12.12.-01 Class 1 Div. 2 – Haz. Loc, ATEX-95 Category 3G (Zone 2)

### Reliability

#### MTBF

74.5 years

#### Warranty

5 years (standard)

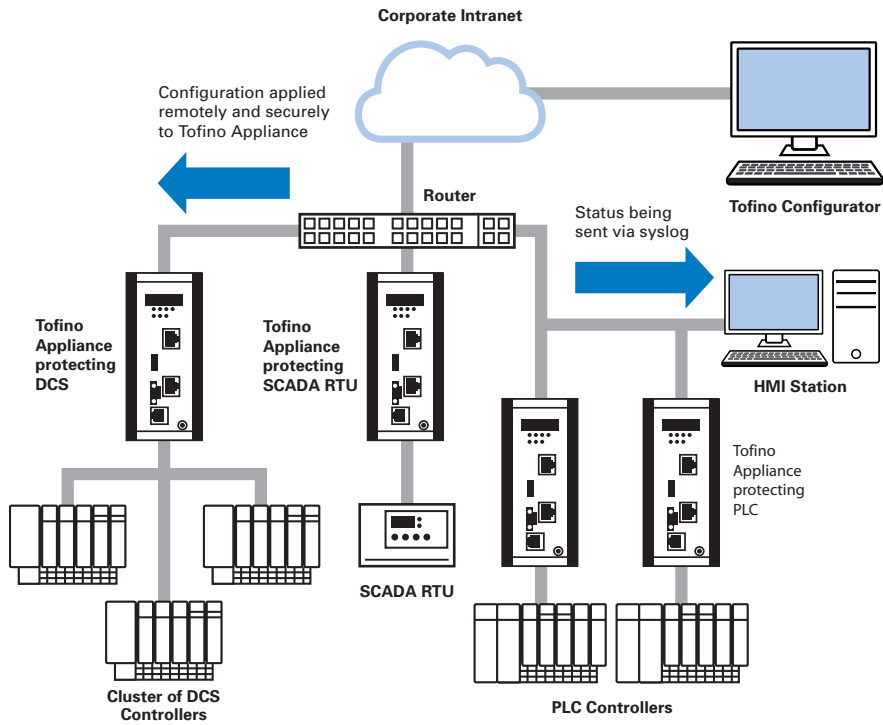

**DIMENSIONS**

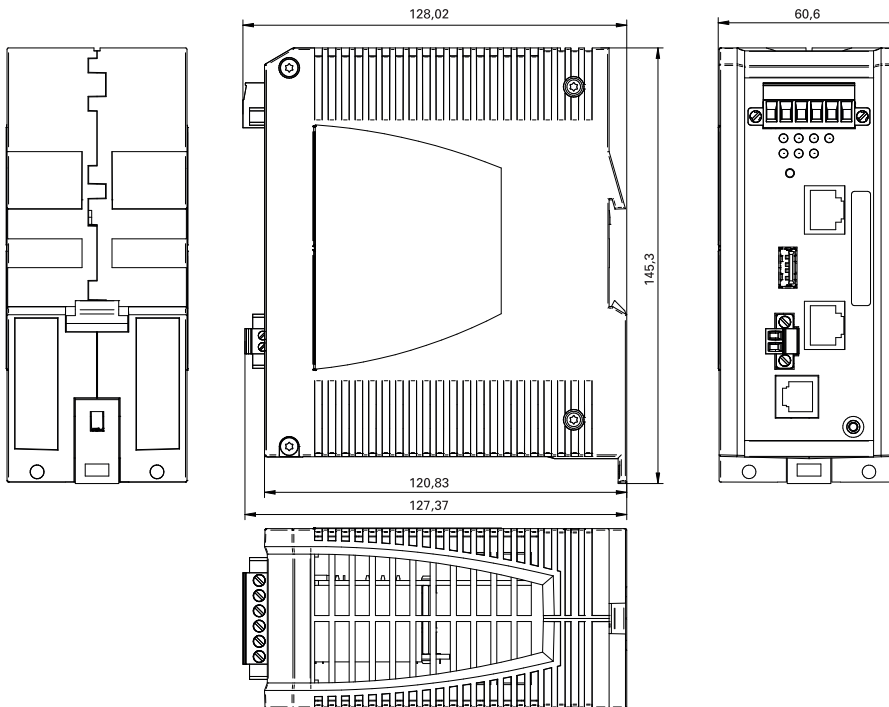

**Measurement Technology Limited,**  
 Great Marlings, Butterfield, Luton  
 Beds, LU2 8DL, UK.  
 Tel: + 44 (0)1582 723633 Fax: + 44 (0)1582 422283  
 E-mail: mtlenquiry@eaton.com  
 www.mtl-inst.com

© 2016 MTL  
 All Rights Reserved  
 Publication No. EPS MTL 9202-ETS rev2 080316  
 March 2016

**EUROPE (EMEA):**  
 +44 (0)1582 723633  
 mtlenquiry@eaton.com

**THE AMERICAS:**  
 +1 800 835 7075  
 mtl-us-info@eaton.com

**ASIA-PACIFIC:**  
 +65 6 645 9888  
 sales.mtlsing@eaton.com

The given data is only intended as a product description and should not be regarded as a legal warranty of properties or guarantee. In the interest of further technical developments, we reserve the right to make design changes.