

Important notes

The 9000TS System described herein operates on a logic voltage of 24VDC and as standard +24VDC is used for the field contact supply voltage.

External power supplies using higher voltage ac/dc primary sources and optional high voltage field contact voltages may be present if this is the case please ensure the necessary precautions are taken

REV	DATED	DESCRIPTION	AUTHOR	APPROVED
12	02-10-08	Battery Disposal	PC	DF
13	27-10-08	Max system size revised and P925TS-R relay details added	PC	DF
14	12-01-09	Corrected F1 and F2 fuse functions	PC	DF
15	27-03-09	Relay Address Setting Revised	PC	DF
16	29-04-09	Watchdog Relay coil state correction	PC	DF
17	13-06-11	Modified event list, IRIGB section, Trouble shooting guide, Dual redundant.	AI	DF
18	28-05-13	Watchdog Relay Coil & Contact States clarified	PC	DF



© RTK INSTRUMENTS LTD 2005

The copyright in this work is vested in RTK Instruments Ltd and this document is issued for the purpose only for which it is supplied. No licence is implied for the use of any patented feature. It must not be reproduced in whole or in part, or used for tendering or manufacturing purposes except under an agreement or with the consent in writing of RTK Instruments Ltd and then only on the condition that this notice is included in any such reproduction. Information furnished is believed to be accurate but no liability in respect of any use of it is accepted by RTK Instruments Ltd.



TABLE OF CONTENTS

<i>System 9000TS Event Recorder</i>	1
SECTION 1 - INTRODUCTION	8
SECTION 2 - SYSTEM DESCRIPTION AND FEATURES	9
<i>GENERAL</i>	9
<i>UNIVERSAL CARD SLOTS</i>	10
<i>POLARISATION KEYS</i>	10
<i>SYSTEM CONNECTIONS</i>	10
<i>CUSTOMER CONNECTIONS</i>	10
<i>FULLY FIELD CONFIGURABLE</i>	10
<i>PRINT OUTS</i>	10
<i>FIRST-UP ALARMS</i>	11
<i>SYSTEM RELAYS</i>	11
<i>TIME DELAYS</i>	11
<i>AUTO SHELVE</i>	11
<i>SLEEP MODE</i>	11
SECTION 3 – MECHANICAL DETAILS	12
<i>LOGIC RACK</i>	12
<i>MOUNTING</i>	12
<i>EARTHING</i>	12
<i>PLUG-IN CARDS</i>	12
<i>LAMP / LED DISPLAYS</i>	12
<i>MULTIPLE RACKS SYSTEMS</i>	13
<i>CHASSIS INTERCONNECTING RIBBON DETAILS</i>	13
SECTION 4 – OPERATING INSTRUCTIONS	14
<i>PRE-CHECKS</i>	14
<i>STATUS LED</i>	14
<i>POWER ON</i>	14
SECTION 5 – TECHNICAL SPECIFICATION	15
<i>LOGIC SUPPLY</i>	15
<i>SUPPLY CURRENT</i>	15
<i>INDIVIDUAL REPEAT RELAYS</i>	15
<i>COMMON RELAYS</i>	15
<i>FUSE RATINGS</i>	15
<i>EMC COMPLIANCE</i>	16
<i>CONDUCTED RFI IMMUNITY</i>	16
<i>RADIATED EMISSIONS</i>	16
<i>CONDUCTED EMISSIONS</i>	16
<i>RADIATED POWER FREQUENCY MAGNETIC FIELD</i>	16
<i>ESD EFFECTS</i>	16
<i>DIELECTRIC WITHSTAND</i>	16
<i>SURGE WITHSTAND – OSCILLATORY</i>	16
<i>ELECTRICAL FAST TRANSIENT/BURST IMMUNITY</i>	16
<i>SURGE IMMUNITY</i>	16
<i>ENVIRONMENT</i>	16
<i>INPUT SPECIFICATIONS</i>	17
<i>OUTPUT SPECIFICATIONS</i>	17
SECTION 6 – ALARM SEQUENCES	18
<i>SUMMARY</i>	18
<i>ISA A – AUTOMATIC RESET – LOCK IN</i>	20



ISA A-4 – AUTOMATIC RESET – NON LOCK IN.....	21
ISA A-4-5-6 – STATUS	22
ISA M – MANUAL RESET – LOCK IN.....	23
ISA R – RINGBACK	24
ISA F1A-1 – AUTOMATIC RESET FIRST UP.....	25
ISA F2M-1 – MANUAL RESET FIRST UP	26
ISA F3A – AUTOMATIC RESET FIRST UP	28
SECTION 7 – P925TS-X INTERFACE CARD	30
INTERFACE CARD FEATURES.....	30
DIAGNOSTIC LED'S	30
SERIAL PORTS.....	30
GENERATING REPORTS.....	31
BUFFERS.....	31
SORT DELAY PERIOD.....	31
SYSTEM RELAY OUTPUTS	32
AUDIBLE ALARM RELAYS.....	32
GROUP RELAYS.....	32
GROUP RELAYS WITH REFLASH.....	32
DIAGNOSTIC RELAY OUTPUTS.....	32
WATCHDOG RELAY.....	32
TIME SYNCHRONISATION.....	33
TIME SYNCHRONISATION JUMPER SETTING.....	33
INTERFACE CARD RELAY OUTPUTS.....	34
SYSTEM RELAY SETTINGS:-	35
SETTING RELAY CONTACT STATES.....	35
HORN RELAY:- RL1	36
HORN RELAY:- RL2	36
GROUP RELAYS RL3 & RL4:-	37
RELAYS RL5 - RL8:-.....	38
REFLASH COMMON ALARM RELAYS.....	38
POWER FAILURE MONITORING:- PF.....	39
PRINTER FAILURE ALARM.....	40
TIME SYNC. FAILURE	40
BUFFER OVERLOAD ALARM.....	40
WATCHDOG RELAY:- WD.....	40
SECTION 7A – P925TS-X1/2 DUAL REDUNDANT INTERFACE CARD	41
DUAL INTERFACE CARD FEATURES.....	41
DIAGNOSTIC LED'S	41
DUAL REDUNDANT SYSTEM.....	41
DOMINANT X1 AND SUBMISSIVE X2	41
DOMINANT X1 CONTROL FUNCTION.....	42
SUBMISSIVE X2 CONTROL FUNCTION	42
SWITCHOVER PROTOCOL.....	42
SWITCHOVER SCENARIO'S	42
TABLE BELOW LISTS EVENT TYPE'S SPECIFIC TO A DUAL REDUNDANT 9000TS SYSTEM.....	44
DUAL REDUNDANT SPECIFIC EVENT TYPE'S.....	44
SECTION 8 – INPUTS AND OUTPUTS.....	46
OPTICALLY COUPLED INPUTS	46
DIGITAL INPUTS	46
LOCK IN	46
LAMP/LED OUTPUTS	46
REPEAT RELAY OPTION	46
DUAL HORN RELAY.....	46
GROUP RELAYS.....	47



REFLASH FACILITY.....	47
WATCHDOG RELAY.....	47
RS485 COMMUNICATION OPTION.....	47
RS232 PRINTER PORT.....	47
RS232 PROGRAMMING PORT.....	47
CONTROL INPUTS.....	47
GROUP INHIBITS.....	47
DATA STORAGE.....	48
SECTION 9 – P925TS-I INPUT CARD.....	49
SIGNAL INPUT VOLTAGE SELECTION.....	49
OPTIONAL HIGH VOLTAGE INPUTS.....	50
POWER ON / STATUS LED.....	50
ALARM STATUS LED'S.....	51
INPUT CARD FACE PLATE & WIRING.....	51
PUSHBUTTON CONNECTIONS.....	52
SECTION 10 – P925TS-O OUTPUT CARD.....	53
LAMP PROTECTION.....	53
OUTPUT DRIVE TYPE.....	53
CARD ADDRESS SETTINGS.....	53
POWER ON / STATUS LED.....	53
LAMP / LED OUTPUT STATUS LED.....	54
SECTION 11 – P925TS-R RELAY CARD.....	55
STATUS LED.....	55
RELAY STATUS LED'S.....	55
OPERATING MODE.....	55
CONTACT STATE.....	57
COIL STATE.....	57
SECTION 12 – LOGIC AND SIGNAL POWER OPTIONS.....	59
STANDARD SYSTEMS USING 24VDC LOGIC AND SIGNAL POWER.....	59
LOGIC SUPPLY.....	59
SIGNAL SUPPLY.....	59
OPTIONAL ISOLATED 24VDC SIGNAL INPUT POWER.....	60
LOGIC SUPPLY.....	60
SIGNAL SUPPLY.....	60
OPTIONAL 125VAC/DC HIGH VOLTAGE SIGNAL INPUTS.....	61
LOGIC SUPPLY.....	61
SIGNAL SUPPLY.....	61
OPTIONAL 48 OR 250VAC/DC HIGH VOLTAGE SIGNAL INPUTS.....	62
LOGIC SUPPLY.....	62
SIGNAL SUPPLY.....	62
SECTION 13 – CARD ADDRESS SETTINGS.....	63
P925TS-I INPUT / P925TS-O OR P925TS-R OUTPUT CARD TYPICAL ADDRESSES SETTINGS.....	64
SECTION 14 – END OF LINE LOAD.....	65
SECTION 15 – INTER CARD COMMUNICATIONS.....	66
UNIVERSAL CARD SLOTS.....	66
P9000TS LOCAL RTK COMMUNICATION SWITCH LOCATION AND SETTING.....	66
UPPER RACK SWITCH SETTINGS.....	67
LOWER RACK SWITCH SETTINGS.....	67
SECTION 16 – EXAMPLES OF 9000TS SYSTEMS.....	68

<i>P9000TS SOE ONLY CARD LAYOUT</i>	68
<i>9000TS SOE AND ANNUNCIATOR CARD LAYOUT</i>	69
<i>9000TS SOE ANNUNCIATOR AND REPEAT RELAY LAYOUT CARD</i>	70
<i>TYPICAL CARD LOCATION AND ADDRESS SETTINGS WITHIN THE P925TS-RK RACK</i>	71
SECTION 17 – 9000TS EVENT TYPE KEY	74
<i>P925TS-I INPUT CARD EVENT TYPE KEY</i>	74
<i>P925TS-O OUTPUT CARD EVENT TYPE KEY</i>	75
<i>P925TS-R RELAY CARD EVENT TYPE KEY</i>	75
<i>9000TS SYSTEM INTERNAL EVENT TYPE KEY</i>	75
SECTION 18 – PORT 1 SERIAL COMMUNICATIONS	78
<i>PORT 1 PROTOCOL FORMATS</i>	78
<i>AMS TIME STAMPED EVENT PROTOCOL</i>	78
<i>MODBUS RTU PROTOCOL</i>	78
<i>READ REQUEST – MASTER</i>	78
<i>READ RESPONSE – 9000TS SLAVE</i>	81
<i>WRITE SINGLE REQUEST/RESPONSE – MASTER AND 9000TS SLAVE</i>	81
<i>WRITE MULTIPLE REQUEST – MASTER</i>	82
<i>WRITE MULTIPLE RESPONSE – SLAVE</i>	82
<i>EXCEPTION RESPONSE – 9000TS SLAVE</i>	83
SECTION 19 – PORT 2 SERIAL COMMUNICATION	84
<i>PORT 2 PROTOCOL FORMATS</i>	84
<i>PROG</i>	84
<i>MODBUS RTU</i>	84
<i>MODBUS RTU PROTOCOL</i>	84
<i>READ REQUEST – MASTER</i>	84
<i>READ RESPONSE – 9000TS SLAVE</i>	87
<i>WRITE SINGLE REQUEST/RESPONSE – MASTER AND 9000TS SLAVE</i>	87
<i>WRITE MULTIPLE REQUEST – MASTER</i>	88
<i>WRITE MULTIPLE RESPONSE – SLAVE</i>	88
<i>EXCEPTION RESPONSE – 9000TS SLAVE</i>	89
<i>WHARTON PROTOCOL</i>	89
SECTION 20 – PORT 3 SERIAL COMMUNICATION	90
<i>PORT 3 PROTOCOL FORMATS</i>	90
<i>WHARTON PROTOCOL</i>	90
<i>HOPF PROTOCOL</i>	90
<i>FOXBRGH 9600 E 1 8</i>	90
<i>AUG CAT, G22, ALM</i>	90
<i>MODBUS RTU PROTOCOL</i>	90
<i>READ REQUEST – MASTER</i>	91
<i>READ RESPONSE – 9000TS SLAVE</i>	93
<i>WRITE SINGLE REQUEST/RESPONSE – MASTER AND 9000TS SLAVE</i>	93
<i>WRITE MULTIPLE REQUEST – MASTER</i>	94
<i>WRITE MULTIPLE RESPONSE – SLAVE</i>	94
<i>EXCEPTION RESPONSE – 9000TS SLAVE</i>	95
SECTION 21 – IRIGB – OPTION	96
<i>TIME CODE INPUT SPECIFICATIONS:-</i>	96
<i>CONNECTIONS AND HARDWARE SETTINGS:-</i>	97
<i>IRIGB CARD STATUS INDICATION:-</i>	99
<i>IRIGB DATE AND TIME:-</i>	100
<i>IRIGB SYNC:-</i>	101
SECTION 22 – SPARE PARTS LIST	102

SECTION 23 – SERVICING	103
SECTION 24 – TROUBLE SHOOTING GIUDE	106
<i>STATUS LED ON ALL CARDS FAIL TO ILLUMINATE</i>	106
<i>STATUS LED ON SOME INPUT CARDS FAIL TO ILLUMINATE</i>	106
<i>STATUS LED ON SOME OUTPUT CARDS FAIL TO ILLUMINATE</i>	106
<i>STATUS LED ON SOME RELAY CARDS FAIL TO ILLUMINATE</i>	107
<i>EVENTS LOST DURING POWER DOWN</i>	108
<i>PORT 2 CONFIGURATION (PROGRAMME) DOES NOT WORK</i>	109
<i>INPUT CARD CHANNEL DOES NOT RESPOND TO LOCAL INPUT CHANGE</i>	109
<i>OUTPUT CARD CHANNEL DOES NOT RESPOND TO LOCAL INPUT CHANGE</i>	109
<i>RELAY CARD CHANNEL DOES NOT RESPOND TO INPUT CHANGE</i>	109
<i>INPUT CARD CHANNEL DOES NOT RESPOND TO REMOTE INPUT CHANGE</i>	109
<i>OUTPUT CARD CHANNEL DOES NOT RESPOND TO REMOTE INPUT CHANGE</i>	110
<i>INPUT CARD FAILS TO SIGN ON</i>	110
<i>OUTPUT CARD FAILS TO SIGN ON</i>	110
<i>RELAY CARD FAILS TO SIGN ON</i>	110
<i>SUSTAINED WATCHDOG RELAY FAULT</i>	110
<i>INTERMITTENT WATCHDOG RELAY FAULT</i>	110
<i>SUSTAINED PRINTER WATCHDOG FAULT</i>	111
<i>INTERMITTENT PRINTER WATCHDOG FAULT</i>	111
<i>SUSTAINED AMS WATCHDOG FAULT</i>	111
<i>INTERMITTENT AMS WATCHDOG FAULT</i>	111
<i>UNABLE TO CLEAR STATUS EVENT</i>	111
<i>INTERFACE CARD STATUS LED NOT ILLUMINATED / FLASHING</i>	111
<i>INTERFACE CARD SYNC LED NOT ILLUMINATED / FLASHING</i>	112
<i>CARD FUNCTIONS INCORRECTLY</i>	112
<i>UNABLE TO SILENCE AUDIBLE / HORN ON INPUT CARD ONLY SYSTEM</i>	112
<i>SILENCE AUDIBLE / HORN ON INPUT CARD ONLY SYSTEM UNRESPONSIVE</i>	112
SECTION 25 – CONTACT	113
PROCEDURES FOR FACTORY REPAIR AND RETURN WARRANTY	113

SECTION 1 - INTRODUCTION

The 9000TS system is modular in design and can be used to display alarms for immediate action and / or to record and print alarms for later analysis.

Typical systems comprise:-

- Stand alone Sequential Event Recorder providing time stamping of events to a 1mS resolution.
- Sequential Event Recorder with Combined Alarm Annunciation features and Remote Displays
- Sequential Event Recorder with Combined Alarm Annunciation features, Remote Displays and Signal Duplicating Relays.
- Stand alone Remote Logic Annunciator systems
- Optional Alarm Management Software (AMS)

9000TS Systems are fully programmable using RTK's windows based software utility which is provided free of charge.

A programming port, RS232, is provided on the front of the Interface Card for connection to a suitable PC / Laptop and no special programming language skills are required as the user can simply enable or disable pre-defined features on a per channel basis and the revisions can be down loaded to the system via the Interface Card. Configuration data is stored in EEPROM on the individual cards without the need for battery back-up.

9000TS Systems are constructed using a combination of the following key parts

MODEL NUMBER	FUNCTION
P925TS-RK	19" Rack Chassis (Base Unit)
P925TS-RK-ETN	19" Rack Chassis (Expansion Unit)
P925TS-X	Interface Card
P925TS-I	16 channel Input Cards
P925TS-O	16 channel Output Cards
P925TS-R	16 channel Repeat Relay Cards
P925TS-BL	Blanking Plates (For unused positions)
P925TS-CABLE-1	Rack Interconnection Ribbon Cable 1 metre length (standard)

SECTION 2 - SYSTEM DESCRIPTION AND FEATURES

General

9000TS Systems are constructed using industry standard 19" Racks with front access to the associated logic cards and rear access to custom terminals. All terminals are of the rising clamp type suitable for a maximum of 2.5mm sq. wire and each terminal block can be removed to aid installation. Terminal blocks are provided with locking screws for increased security during normal operation.

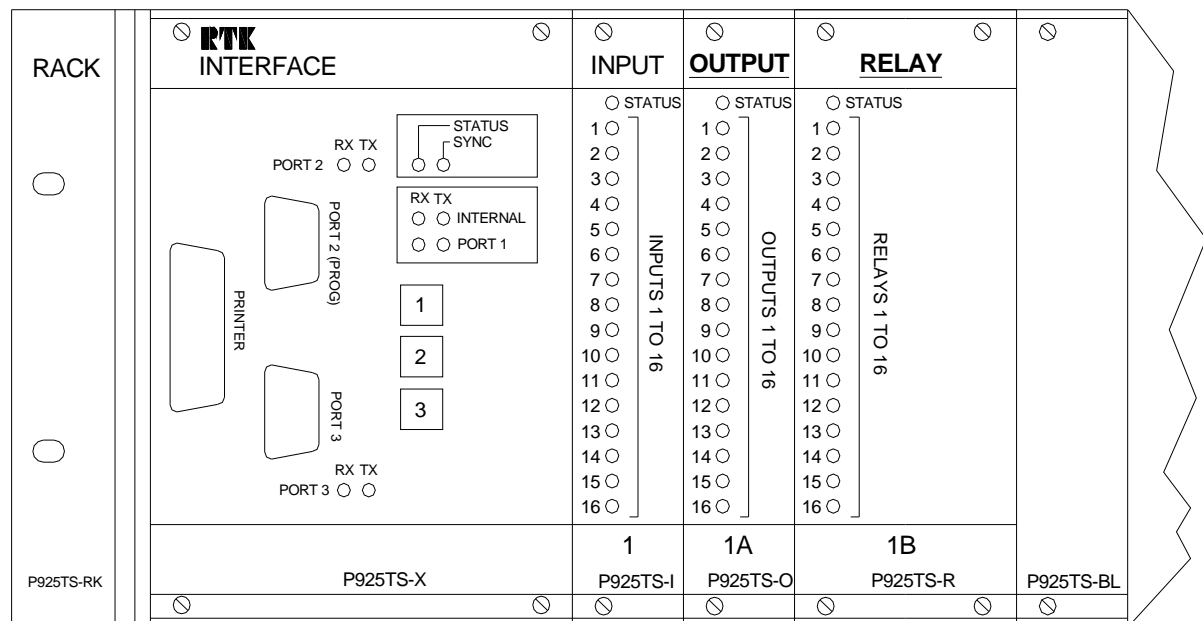

A P925TS-RK 19" 3U Base Rack with 13 card slots is supplied with each system and the following can be used as required.

- P925TS-X Interface Card
- P925TS-I Input Cards (16 channel)
- P925TS-O Output Cards (16 channel)
- P925TS-R Relay Cards (16 channel)
- P925TS-BL Blanking Plates to protect and cover unused positions
- P925TS-RK-ETN 19" 3U Expansion Racks with 14 card slots

Any combination of Input, Output or Relay Cards can be used to suit individual applications. Ribbon sockets are provided on the rear of each rack allowing all of the common system bus to be linked to expansion racks using factory supplied ribbon cables.

Each Rack is equipped with its own 24VDC Logic and Signal Supply Fuse for added protection and status LED's are provided per fuse.

Universal Card Slots

All card slots within the racks are universal in application therefore Input, Output or Relay Cards can be inserted into any available slot. Cards are inserted from the front of the rack and once inserted automatically connect to the customer terminals located on the rear of the chassis. Locking screws are provided at the top and bottom of each card to ensure they are firmly seated at all times.

Polarisation Keys

For added security all cards and slots are supplied with polarisation keys to prevent accidental insertion into the incorrect position within the racks. The polarisation can be changed but care must be taken to ensure the associated field wiring is disconnected and re-wired before cards of a different type are inserted into slots previously occupied by different card types. For example high voltage inputs may have been used on a socket that it being upgraded for use with low voltage outputs.

System Connections

In larger applications multiple racks can be used to form larger systems and common bus connections between racks are linked via RTK supplied plug in ribbon cables. These connect to dedicated ribbon sockets located on the rear of each rack and are labelled ribbon IN and ribbon OUT. The standard ribbon is 1mtr in length but additional length cables can be supplied at time of order if required.

Customer Connections

Industry standard rising clamp terminal blocks, capable of accepting a maximum of 2.5mm² cable are provided on the rear of each rack for connection of logic power, signal power, signal inputs, lamp and relay outputs. Locking screws are provided at the top and bottom of each terminal block to allow them to be easily removed during installation, commissioning or fault finding.

Fully Field Configurable

Each channel within the 9000TS System can be configured by the customer using the RTK supplied software utility and all programming information is stored in non-volatile memory on individual cards with a minimum of 20 years retention. Full details of the software and available features are provided via a separate manual.

Print Outs

A dot matrix printer can be directly connected to the P925TS-X Interface Card to dynamically print the alarms as they occur or the user can choose to disable the print function for later analysis. 3 tactile pushbuttons located on the face of the Interface Card allow the user to trigger predefined reports as detailed later in this manual.

First-Up Alarms

When a group of alarms is initiated, it is often critical to know the first alarm to occur within the group as it allows the user to quickly identify the primary cause of failure. This should reduce downtime and allow the plant to be returned to the operational state in the shortest possible time. A printout of events to a 1mS resolution and or a First-Up alarm sequences can be used to identify the primary cause of failure.

System Relays

Eight relays are provided within the P925TS-X Interface Card comprising two horn relays and six common relays, which can be software configured to provide common alarm group or failure alarm contacts for use with 3rd party devices.

Time Delays

Whilst some of the alarms in the system may require events to be captured to a 1ms resolution some of the alarms may not need to respond in the same manner. Input Cards are therefore provided with incremental time delays that allow the user to configure each channel to activate and / or de-activate after a pre-set time limit has elapsed. Each channel can be selected between 1 and 65,000ms

Auto Shelve

When high-speed events are being captured and stored in logs a faulty input contact to an alarm channel can quickly fill the associated event buffers. Each channel can be software configured to automatically shelve an alarm if the frequency of alarms exceeds the specified norm within a defined time period. Once the channel returns to set limits it will be automatically removed from auto shelve and will carry on responding in the normal way. When auto-shelve occurs the event is stored in memory and printed as required.

Sleep Mode

In applications where plant areas are not manned on a permanent basis – Sleep Mode – can be used to disable the output drives to Displays and Audibles. This feature is used to minimise drain on the primary power source, (typically batteries), and to prevent unnecessary noise pollution.

Sleep mode is a standard feature of the 9000TS System and it is important to note that whilst in this mode the logic continues to respond to alarms in the normal manner. The pushbutton functions are disabled during sleep mode to ensure that once this feature has been turned off the operator can use the associated pushbuttons to control the alarms in the normal way.

SECTION 3 – MECHANICAL DETAILS

Logic Rack

The 9000TS System is mounted in industry standard 19" Racks manufactured to IEC297-3 (DIN1494 Pt5). On larger systems multiple racks are supplied and ribbon cables, which plug into dedicated sockets on the rear of each rack, are used to link common bus lines.

When mounting the rack care must be taken to ensure that there is sufficient room to withdraw the cards from the front of the rack and for cable access to the rows of 16 way terminals mounted on the rear of the rack. Customer inputs and outputs are capable of accepting cable up to a maximum of 2.5mm² and each terminal block can be removed for ease of wiring using the locking screws provided at either end of the block

Mounting

The 19" Rack should be mounted in a location that is free from excessive moisture, vibration, heat and dust with sufficient clearance at the front to withdraw all cards without obstruction and space at the rear to connect the associated field wiring. All spare positions in a rack are fitted with all of the necessary edge connectors and chassis blanking plates for ease of expansion at a later date. Additional Input, Output or Relay Cards can therefore be plugged in and connected with ease.

Earthing

To comply with the EMC requirements for electrostatic discharge IEC801-2 it is essential that each 19" Rack is suitably earthed. A dedicated earth point is supplied on the right hand side plate of each rack for this purpose.

Plug-in Cards

The first rack in any system is supplied with one P925TS-X Interface Card and thirteen vacant card slots, which can be used for a combination of :-

CARD TYPE	FUNCTION	SPACE REQUIRED
P925TS-1	16 Channel Input Card	One Card Slot
P925TS-O	16 Channel Output Card	One Card Slot
P925TS-R	16 Channel Repeat Relay Card	Two Card Slots
P925TS-BL	Blanking Plates	One Card Slot

Once the cards are plugged into the rack they automatically connect to the motherboard to link all of the control functions between cards and to provide connections to the Customer terminals mounted on the rear of the rack.

Lamp / LED Displays

The 9000TS System is able to drive existing displays or RTK can supply the system with RTK manufactured display units as required.

Multiple Racks Systems

In larger SOE or combined SOE / Annunciator schemes multiple racks can be supplied as required.

These systems still only 1 x P925TS-X Interface Card for communication to the outside world and to being able to configure the associated cards.

The common signals required between racks are fully buffered and are connected using RTK supplied plug in ribbon cables which connect into dedicated sockets on the rear of the associated racks as typically shown below.

Chassis Interconnecting Ribbon Details

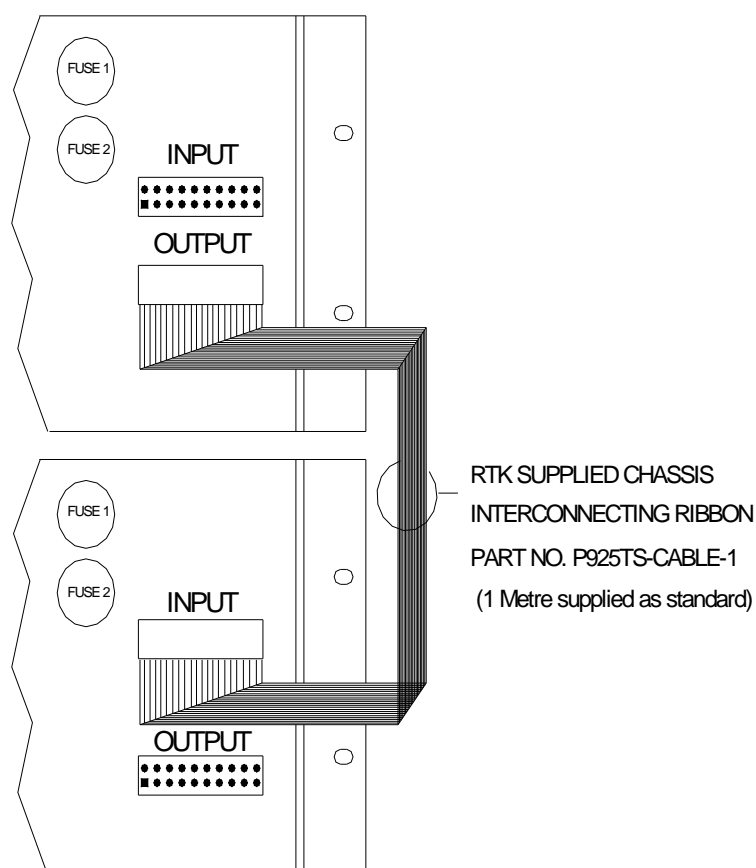

SECTION 4 – OPERATING INSTRUCTIONS

Pre-checks

The system is supplied fully tested and, if requested, pre-configured to suit your application so detailed on site re-testing should not be necessary.

After connections have been completed the following pre-checks should be made before applying power.

1. Ensure the equipment is earthed using the specific earth stud on the right-hand side of the P925TS-RK Euro-rack.
2. Check that the power supply is adequately rated and suitable for the primary supply available and that the output voltage is suitable for use with the 9000TS system.
3. The 9000TS System requires a 24VDC logic supply and the 24VDC signal supply is derived from this supply as standard. (Options exists for high voltage inputs fed via external power source as detailed within this manual)
4. Check that all cards are fully seated and the retaining screws have been tightened.
5. Check all alarm contacts are volt-free and correctly wired using the common voltage +24VDC available on terminal +VC for standard systems (Options exists for high voltage inputs fed via external power source as detailed within this manual)
6. Care should be taken with the output wiring to the display to ensure no shorts occur.
7. Please note a short in the output will not damage the equipment but could give extremely misleading results.

Status LED

Each card is supplied with a status LED which is used for fault and setup indication as follows:-

LED	STATUS
ON	Normal Operation
OFF	Faulty card or card not recognised in software

Power ON

After completing the above pre-checks, power can be supplied to the unit. The system will complete an initial self-test and will search for all of the installed cards. During this time the status LED on the associated input / output card will illuminate as soon as the system recognises the card and its settings.

SECTION 5 – TECHNICAL SPECIFICATION

Logic Supply 24VDC (19 to 36VDC)

A range of power supplies are available to convert from higher AC or DC primary supply voltages.

Supply Current @ 24VDC for all card types

MODEL NO	TYPE	CURRENT
P925TS-X	Interface Card	1A
P925TS-I	Input Card	100mA
P925TS-O	Output Card	100mA plus Lamp / LED load
P925TS-R	Relay Card	250mA
RTK LED	LED Cluster	20mA each
RTK 28V	Lamp	40mA each

Individual Repeat Relays

VOLTAGE	RATING (RESISTIVE)
24VDC	2A
125VDC	0.5A

Common Relays

VOLTAGE	RATING (RESISTIVE)
24VDC	2A
125VDC	0.5A

Fuse ratings

FUSE	RATINGS	PURPOSE
F1	1A/T	Protects the +24VDC signal supply from each chassis
F2	5A/F	Protects the main 24VDC logic supply to each chassis

Alarm Sequences Compliant to ISA Standard S18.1 – 1979 (R.1992)
Each channel can be configured to operate in accordance with the standard ISA sequences detailed in ISA-S18.1 1979.

Terminals Rising clamp type terminals complete with locking screws.
Maximum cable size 2.5 mm Square

EMC Compliance

Radiated RFI Immunity

IEC 61000-4-3

Conducted RFI Immunity

IEC 61000-4-6

Radiated Emissions

IEC 61000-6-3

Conducted Emissions

IEC 61000-6-3

Radiated Power Frequency Magnetic Field

IEC 61000-4-8

ESD Effects

IEC 61000-4-2

Dielectric Withstand

1500V RMS

Surge Withstand – Oscillatory

ANSI C37.90.1

Electrical Fast Transient/Burst Immunity

IEC 61000-4-4

Surge Immunity

IEC 61000-4-5

LVD Compliance

Designed and manufactured to BS EN61010-1:1993

Environment

Operating temperature 0oC to 60oC

Storage temperature -20oC to 80oC

Humidity 0-95% RH, non-condensing

Input Specifications

Contact	Volt Free contacts that can be software configured to be either normally open or normally closed.
Voltage	24V AC/DC with selectable option per channel for 125VAC/DC (Options for 48VAC/DC or 250VAC/DC)
Contact resistance	N/C series resistance of contact cables 20K Ohm max
Contact resistance	N/O parallel resistance of contact cables 200K Ohm min
Alarm contact current	Typical loop current 2mA
Input response time	Selectable form 1mS to 65,000mS
First up discrimination	1mS
Input protection	The equipment is protected against reverse connection of the supply input.
Pushbuttons	Control pushbuttons can be software configured as required and normally use +24VDC as a common return in systems using high voltage inputs they use the same return as the signals (48VAC/DC, 125VAC/DC or 250VAC/DC)

Output Specifications

Output cards	Each channel can drive up to 160mA @ 24VDC, making it suitable for multi bulb / LED displays or multiple repeat displays.
System relays	There are eight systems relays comprising two horn relays and six common relays, which can be configured as group or fault relays. A volt free contact is provided per relay, which can be set to normally open or normally closed as required. All contacts are rated at 2A @ 24VDC
Repeat relays	As an option 16 channel repeat relay cards are available which provide a volt free contact per relay, which can be set to normally open or normally closed as required. All contacts are rated at 2A @ 24VDC
Communications	RS485 Bi-directional modbus communication port, 9 Pin programming port and 25 Pin printer port.

SECTION 6 – ALARM SEQUENCES

On systems supplied with P925TS-O Output Cards each channel can be programmed to operate to a sequence defined within ISA-S18.1 Alarm Sequences. Full details of how to set each channel to the required alarm sequence are provided in the 9000TS Configuration Manual.

The following paragraphs detail the most common features.

Summary

Within the alarm annunciator market a common standard has been adopted by all key manufacturers and end users with regards to operational sequences. These standards are used worldwide to define the visual indication, audible alarm and the action the operator must take to control the annunciator.

The Instrument Society of America provide full details of each alarm sequence within ISA 18.1-1979 (R1992) and RTK are fully compliant with the stated sequences. The most common sequences are detailed within this section of the manual.

Pushbuttons

Six pushbutton functions are provided within the 9000TS System to allow the user to be able to control any of the available sequences.

1. **Lamp Test** – is used to test the LED assemblies by illuminating them in a steady state for as long as the pushbutton is pressed
2. **Functional Test** – is used to simulate an input on all channels and therefore all windows and horn circuits will operate in accordance with the selected ISA sequence and additional pushbuttons will need to be pressed to step through the alarm sequence to return the unit to its normal state
3. **Mute** – is used to silence the audible alarm whilst allowing the associated alarm window to continue to operate in accordance with the selected ISA sequence
4. **Acknowledge** – is used to silence the alarm and change the state of the associated alarm window in accordance with the selected ISA sequence
5. **Reset** – is used to return the alarm to the normal off state once the Input has returned to the normal condition
6. **First Reset** – is used to reset the flash sequence on the first alarm to occur within a defined group of alarms. Once first reset has been pressed the next alarm to occur within the group will flash at the first up alarm rate.

Audible Alarms

Each channel within the annunciator can be set to operate RL1 and RL2 common horn relays as required and RL5 – 8 can be set as additional horn relays as required.

Automatic Reset

Once a channel has been acknowledged and its input has returned to normal the alarm can be set to automatically reset without the operator having to press the reset pushbutton

Non Latch Sequence – (No Lock In)

Alarms can be set to non lock-in, which allows the alarm to automatically return to the non alarm state as soon as the signal input returns to normal

Ringback Sequence

Ringback sequence is used to inform the operator both visually and audibly that an alarm condition has cleared and the channel can be reset to its normal off state. When a contact returns to normal the associated window will flash at approx ½ the speed of a normal alarm and the audible will sound. This identifies the specific alarm and informs the operator that the alarm can be reset to its normal off state.

First Up Sequences

When monitoring devices with interlinked functions such as a turbine or compressor it is often important to know the specific alarm that occurred first, as it will invariably result in cascade of secondary alarms. This allows the operator to focus on the root cause of failure and therefore limits the downtime and associated costs. This is achieved by having the first-up alarm flashing in a different manner compared to the subsequent alarms. Four different first-up sequences are available F0, F1, F2 and F3 as detailed below and in the following sequence tables.

F0 The standard mode adopted by RTK Instruments, which indicates the first-up alarm by flashing at twice the rate of subsequent alarms.

F1 In this mode subsequent alarms appear in the acknowledged state, hence they do not flash. The audible device does not operate when subsequent alarms occur, unless still operating from the first alarm. The acknowledge pushbutton will reset the first-up indication.

F2 In this mode all subsequent alarms do not flash, they will however operate the audible device. The acknowledge pushbutton will reset the first-up indication.

F3 In this mode initial alarms appear with an intermittent flash rate and subsequent alarms flash at a steady rate. On acknowledge subsequent alarms revert to the steady on state and only the first alarm continues to flash at a slower rate.

Please note auto reset and non lock- in functions are not recommended when using first up sequences as the true sequence of events cannot be guaranteed.

The most common sequences are detailed below:-

ISA A – Automatic Reset – Lock In

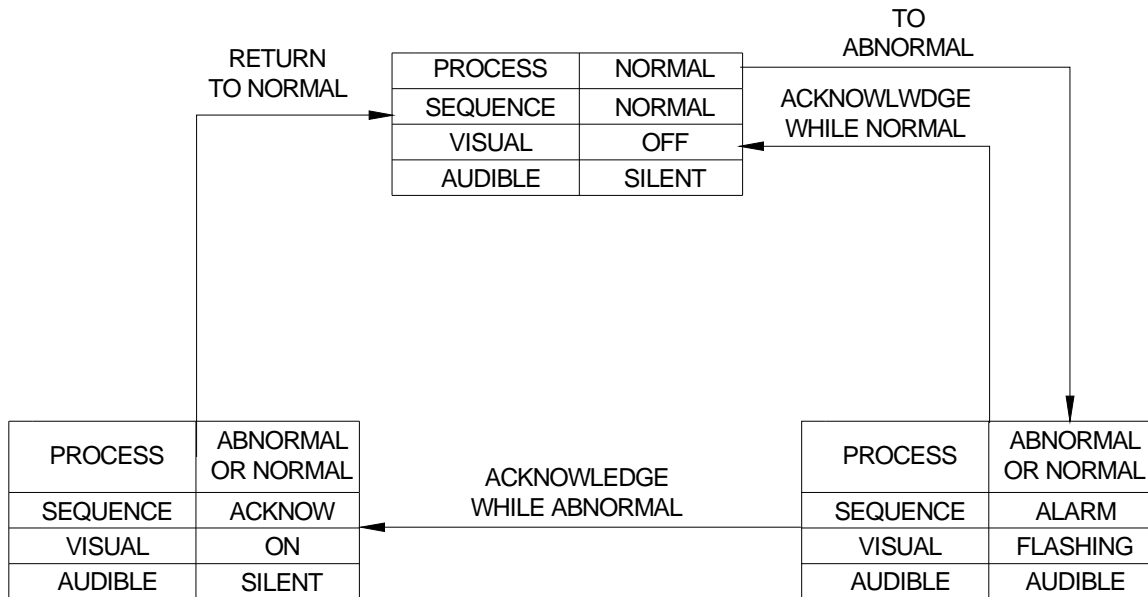

Sequence Features

1. Acknowledge and test pushbuttons.
2. Alarm audible device
3. Lock In of momentary alarms until acknowledged
4. The Audible device is silenced and the flashing stops when acknowledged.
5. Automatic reset of acknowledged alarms when the process has returned to normal
6. Operational test

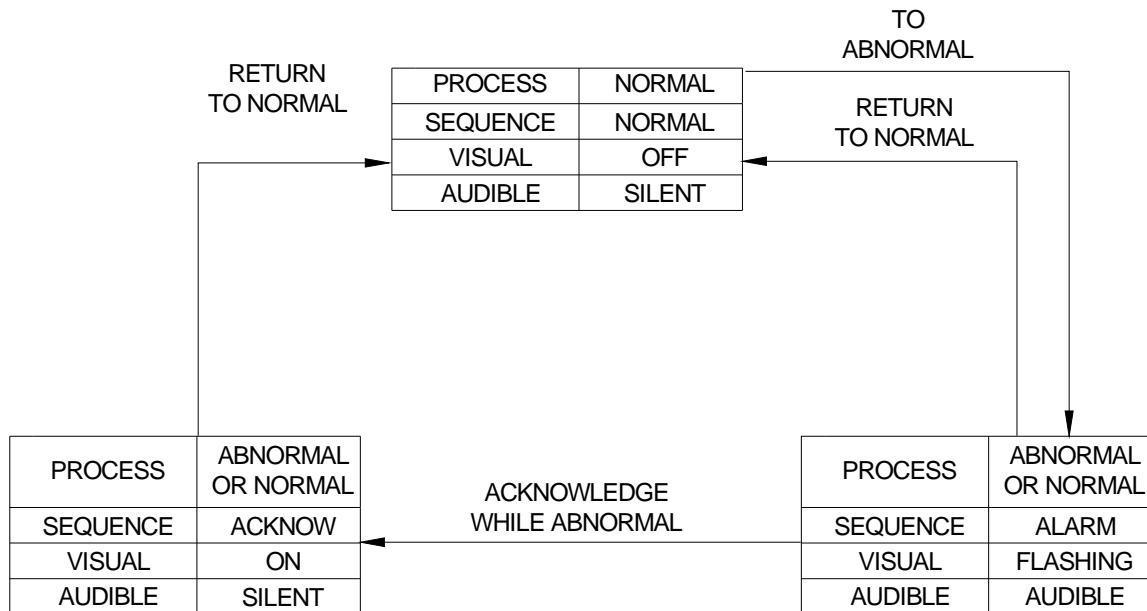
ISA A-4 – Automatic Reset – Non Lock In**Sequence Features**

1. Acknowledge, and test pushbuttons.
2. Alarm audible device
3. Non Lock In of momentary alarms
4. The audible device is silenced and the flashing stops when acknowledged.
5. Automatic reset of alarms when the process has returned to normal before or after acknowledge (Non Lock In)
6. Operational test

ISA A-4-5-6 – Status

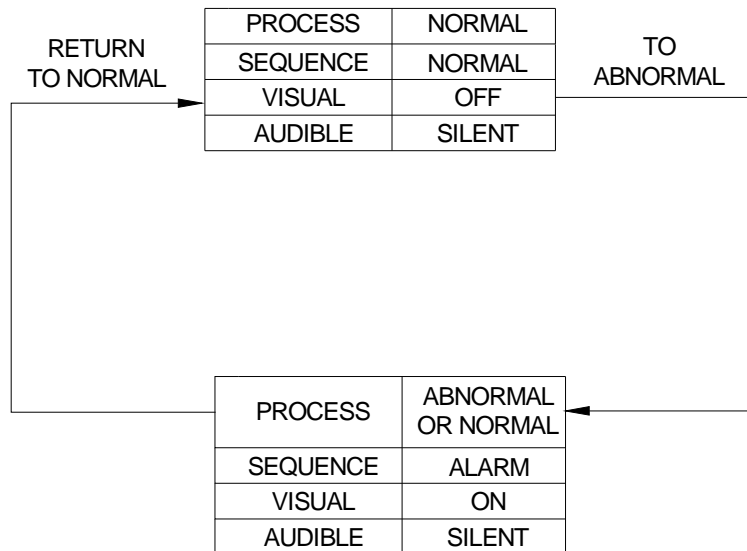

Sequence Features

1. Test pushbutton.
2. No alarm audible
3. The visual alarm does not flash
4. Non Lock In of momentary alarms
5. Automatic reset of alarms when the process has returned to normal before or after acknowledge (Non Lock In)
6. Operational test

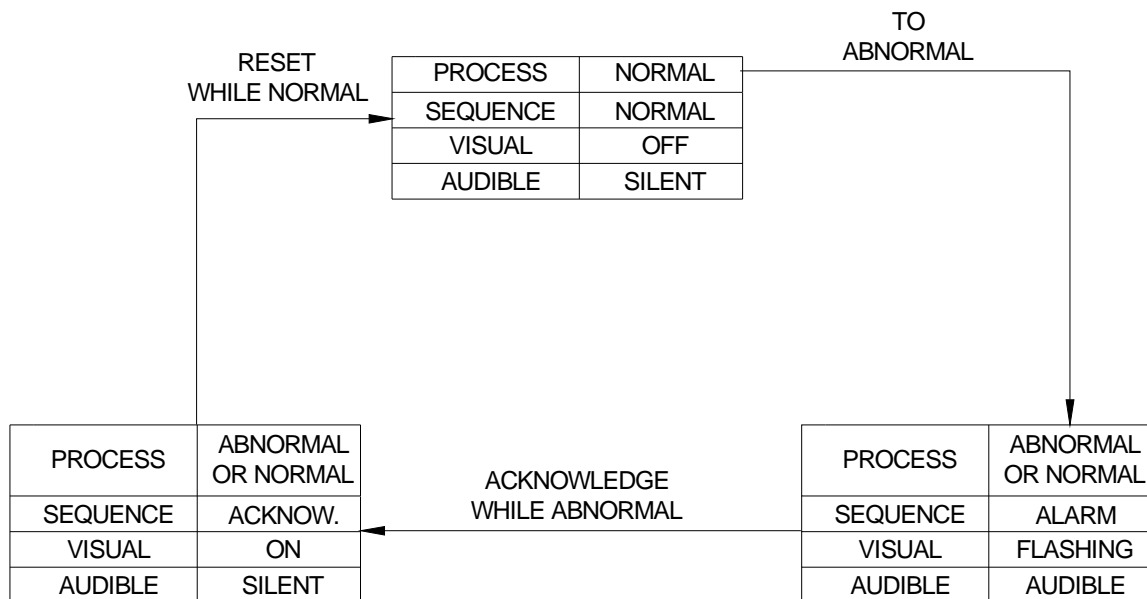
ISA M – Manual Reset – Lock In**Sequence Features**

1. Acknowledge, reset and test pushbuttons.
2. Alarm audible device
3. Lock In of momentary alarms until acknowledged
4. The Audible device is silenced and the flashing visual alarm stops when acknowledged.
5. Manual reset of acknowledged alarms when the process has returned to normal
6. Operational test

ISA R – Ringback

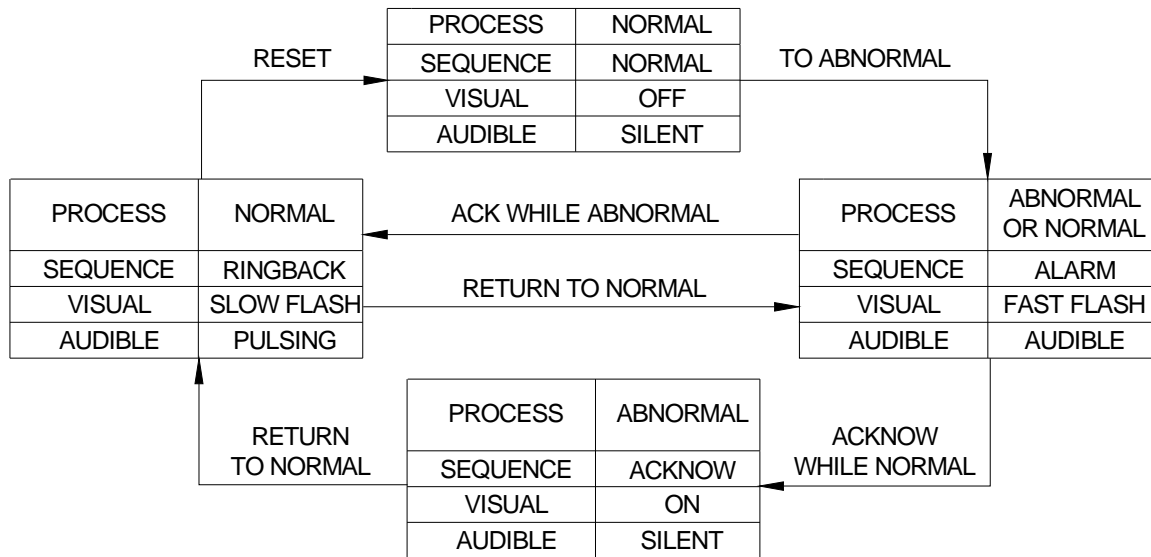

Sequence Features

1. Acknowledge, reset and test pushbuttons.
2. Alarm audible device. (optional Ringback audible device)
3. Lock In of momentary alarms until acknowledged
4. The audible device is silenced and the flashing stops when acknowledged
5. Ringback visual and audible indications when the process condition returns to normal
6. Manual reset of Ringback indications
7. Operational test

ISA F1A-1 – Automatic Reset First Up

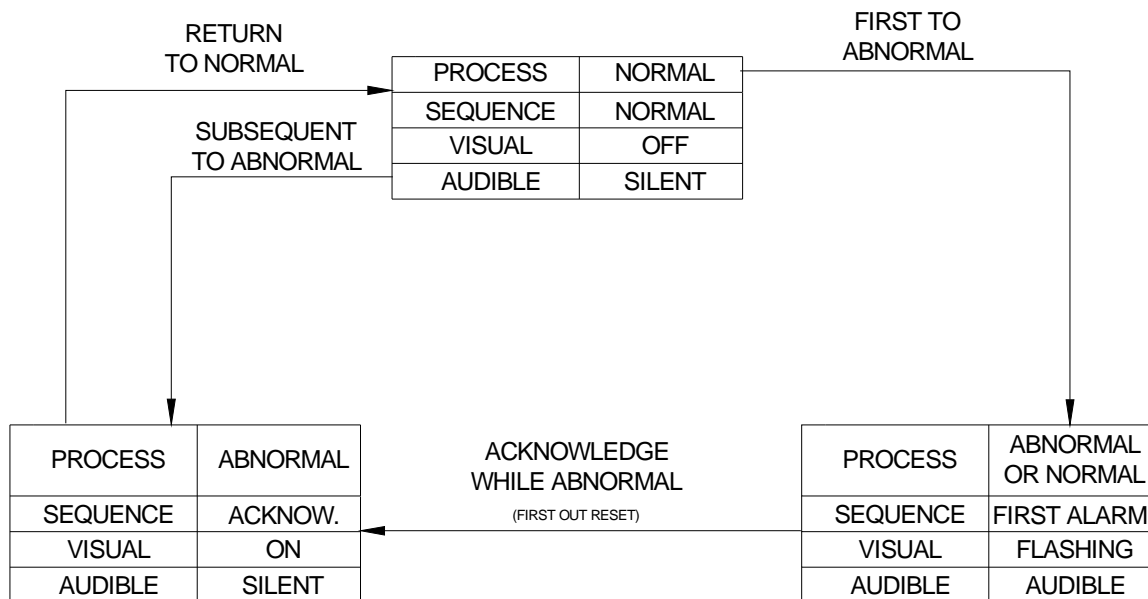

Sequence Features

1. Acknowledge and test pushbuttons.
2. Alarm audible device
3. Lock In of momentary first alarm only, no lock in of momentary subsequent alarms
4. Flashing and audible indications for first alarm only, new subsequent alarms go to the acknowledge state.
5. First out indication is reset and the audible is silenced when acknowledged.
6. Automatic Reset of acknowledged alarm indications when the process returns to normal
7. Silence pushbutton can be used to silence the audible alarm only

ISA F2M-1 – Manual Reset First Up

SEQUENCE DIAGRAM

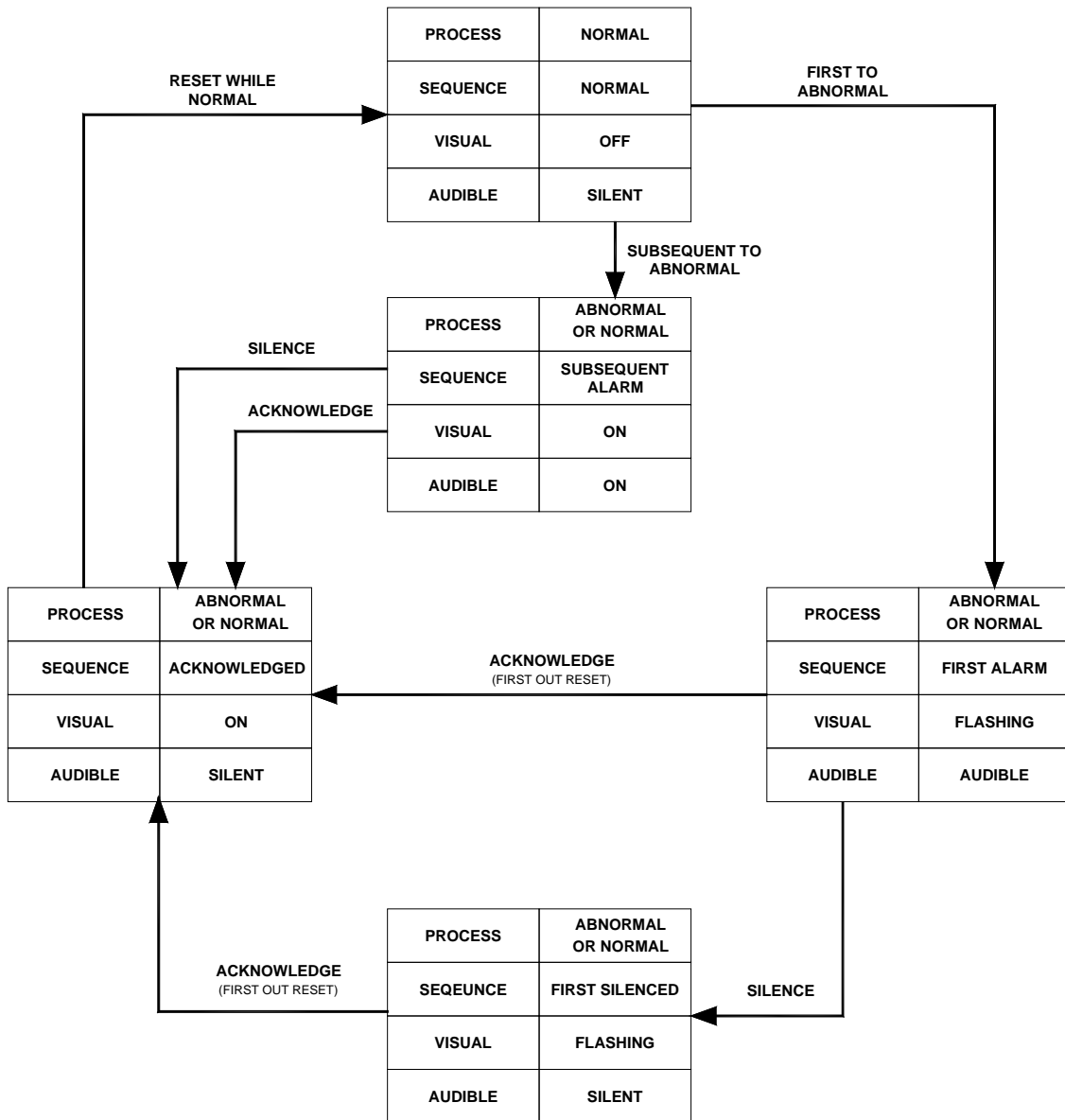

SEQUENCE ISA F2M-1

(MANUAL RESET FIRST OUT WITH NO SUBSEQUENT ALARM FLASHING & SILENCED PUSHBUTTON)

LINE	PROCESS CONDITION		PUSHBUTTON OPERATION	SEQUENCE STATE	VISUAL DISPLAY	ALARM AUDIBLE DEVICE	REMARKS
1	NORMAL			NORMAL	OFF	SILENT	
2	FIRST	ABNORMAL		FIRST ALARM	FLASHING	AUDIBLE	LOCK-IN
3	SUB.	ABNORMAL		SUB. ALARM	ON	AUDIBLE	LOCK-IN
4	FIRST	ABNORMAL OR NORMAL	ACKNOWLEDGE BEFORE SIL	TO LINE 7			FIRST OUT RESET
5	SUB.	ABNORMAL OR NORMAL					
6	FIRST	ABNORMAL OR NORMAL	SILENCE	FIRST SILENCED	FLASHING	SILENT	
7	SUB.	ABNORMAL OR NORMAL	SILENCE	ACKNOWLEDGE	ON	SILENT	MANUAL RESET REQUIRED
8	FIRST	ABNORMAL OR NORMAL	ACKNOWLEDGE AFTER SILENCE	TO LINE 7			FIRST OUT RESET
9	NORMAL		RESET	NORMAL	OFF	SILENT	MANUAL RESET

SEQUENCE FEATURES

1. Silence, acknowledge, reset and test pushbuttons
2. Alarm audible device
3. Lock-in of momentary alarms until acknowledged.
4. Option1 – silence pushbutton to silence the alarm audible device while retaining the first out flashing indication
5. Flashing indication for first alarm only. new subsequent alarms have the same visual indication as acknowledged alarms.
6. First out indication is reset when acknowledged
7. Manual reset of acknowledged alarm indications after process conditions return to normal.
8. Operational test

ISA F3A – Automatic Reset First Up

SEQUENCE DIAGRAM

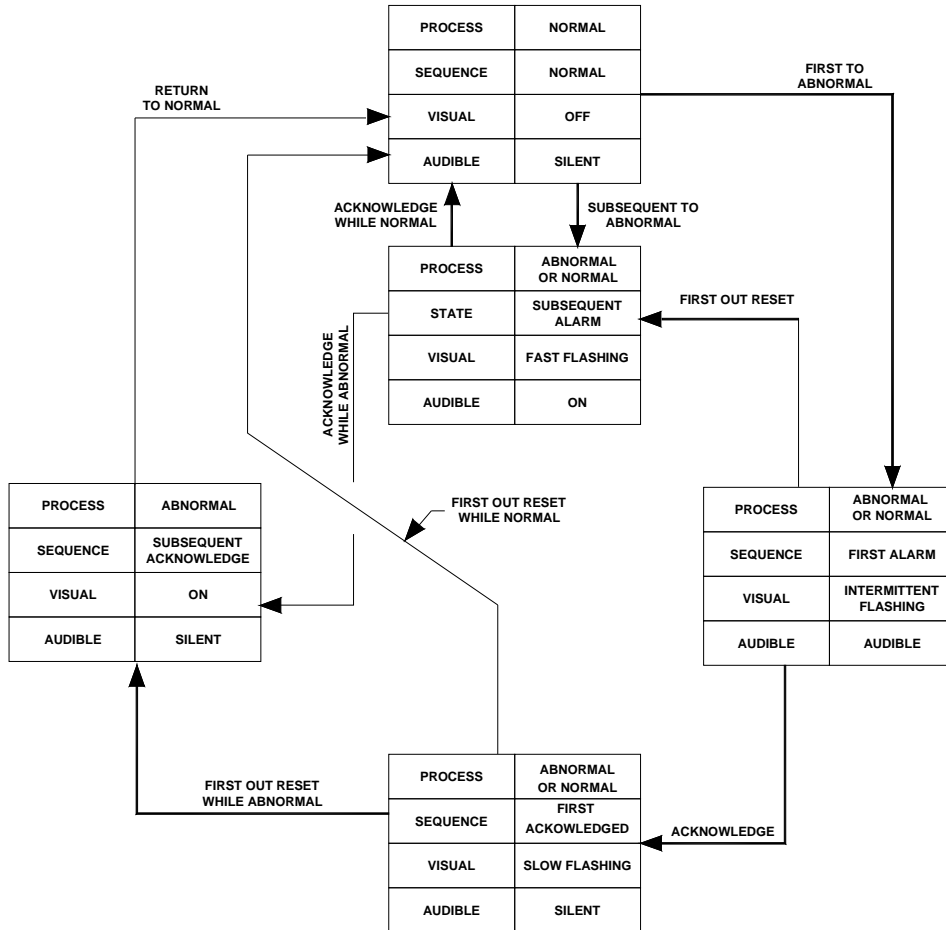

SEQUENCE ISA F3A

(AUTOMATIC RESET FIRST OUT WITHOUT FLASHING & RESET PUSHBUTTON)

SEQUENCE TABLE

LINE	PROCESS CONDITION		PUSHBUTTON OPERATION	SEQUENCE STATE	VISUAL DISPLAY	ALARM AUDIBLE DEVICE	REMARKS
1	NORMAL			NORMAL	OFF	SILENT	
2	FIRST	ABNORMAL		FIRST ALARM	INTERMITTENT FLASHING	AUDIBLE	LOCK-IN
3	SUB.	ABNORMAL		SUB. ALARM	FAST FLASHING	AUDIBLE	LOCK-IN
4	FIRST	ABNORMAL OR NORMAL	FIRST OUT RESET BEFORE ACKNOWLEDGE	TO LINE 3			FIRST OUT RESET
5	FIRST	ABNORMAL OR NORMAL	ACKNOWLEDGE	FIRST ACKNOWLEDGED	SLOW FLASHING	SILENT	FIRST OUT RESET REQUIRED
6A	SUB.	ABNORMAL		SUB. ACKNOWLEDGE	ON	SILENT	MAINTAINED ALARM
6B	SUB.	NORMAL		TO LINE 8			MOMENTARY ALARM
7A	FIRST	ABNORMAL	FIRST OUT RESET AFTER ACKNOWLEDGE	TO LINE 6A			FIRST OUT RESET
7B	FIRST	NORMAL		TO LINE 8			FIRST OUT RESET
8	NORMAL			NORMAL	OFF	SILENT	AUTOMATIC RESET

SEQUENCE FEATURES

1. Silence, acknowledge, reset and test pushbuttons
2. Alarm audible device
3. Lock-in of momentary alarms until acknowledged.
4. Flashing indication for first alarm only. New subsequent alarms have the same visual indication as acknowledged alarms.
5. First out indication is reset when acknowledged
6. Manual reset of acknowledged alarm indications after process conditions return to normal.
7. Operational test

SECTION 7 – P925TS-X INTERFACE CARD

Interface Card Features

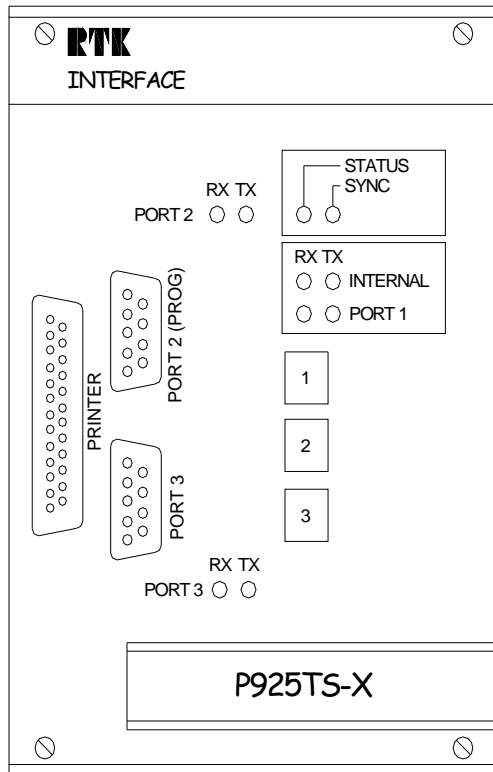

Diagnostic LED's

PORT	TYPE	FUNCTION
1	Modbus Communication	Transmit & Receive LED's
2	Programming	Transmit & Receive LED's
3	Time Synchronisation	Transmit & Receive LED's
	System Status	Power On LED
	Time Sync Status	Time Sync LED

Serial Ports

PORT	TYPE
1	RS485 Modbus Communication Port
2	RS232 Programming Port
3	RS232 Time Synchronisation Port
	RS232 Printer Port (25 Pin)

Generating Reports

Three tactile pushbuttons are provided on the front of the P925TS-X Interface Card to allow the user to trigger pre-defined reports from a 9000TS System using the sequential of event feature.

Caution:-

Depending on the type of report required the resulting print out may be several pages long and therefore the printer will be fully utilised while the print out is in process. To prevent accidental triggering of reports each pushbutton must be held down for a short period to confirm that the report should be printed.

Report Print Outs

PUSHBUTTON	REPORT TYPE
1	Generates a printed report for ALL channels in the alarm condition.
2	Generates a printed report indicating any input that has been shelved because the number of alarm events within a defined period has exceeded the programmed parameters for the specific channel or the channel has been manually shelved in software.
3	Generates a printed report indicating the events stored within the event history buffer. Caution:- this can be in excess of 1,000 events.
1 & 3	Pressed simultaneously generates a printed report indicating the configuration of all alarm legend details
1, 2 & 3	Pressed simultaneously generates a printed report indicating the configuration of all channels in the system

Buffers

The following buffers are available within the interface card.

FUNCTION	CAPACITY
Sort Buffer	1,000 Events
AMS Buffer	1,000 Events
Printer Buffer	1,000 Events

Please note these buffers are in addition to the 1,000 event buffers located on each 16 channel card within the system. As an example a 19" rack containing 13 input cards is capable of storing 13,000 events in addition to the above.

Sort Delay Period

In applications where alarm bursts occur in quick succession the user can software configure a sort time delay period in seconds to ensure that data remains in strict time order. Once the sort delay period has elapsed the information is passed onto the AMS and Printer buffers when requested.

System Relay Outputs

The P925TS-X Interface Card is equipped with eight system relays having the following functions:-

Audible Alarm Relays

Two systems relays RL1 and RL2 are always factory supplied as horn relays on the Interface card. Each channel can be configured to activate relay 1 or relay 2. When the associated channel goes into alarm the horn relay will activate and the relay will remain in the alarm state until the silence or acknowledge pushbutton has been pressed.

Group Relays

RL3 and RL4 are factory set as Group Relay 1 and 2 and RL5 to RL8 can be software configured to operate as group relays. Each channel can be configured to activate any of the group relays. When the associated channel goes into alarm the group relay will activate and the relay will remain in the alarm state until all alarms in the group have returned to normal and the logic has been reset

Group Relays with Reflash

Group Relays can also be configured to include a Reflash function.

In this Mode when an additional alarm occurs within the same group the associated relay contacts will revert to normal for approx 500mS and then re-alarm.

Diagnostic Relay Outputs

Systems relays RL5 to RL8 can be software configured to provide volt free contact outputs for the following events:-

EVENT TYPE
Internal Faults
Printer Faults
Sort Log Full
AMS Log Full
Printer Log Full
GPS Lock Fault
GPS Serial Fault
Sync Fault

Watchdog Relay

A Watchdog Relay RL9 is provided as standard, which will change state as soon as the 9000TS detects an internal communication failure or card fault. The P925TS-X Interface Card is equipped with 2 x Jumpers LK6 and LK8 which allow the contact and coil state. LK6 allows selection of EN (Energised) or DE-EN (De-Energised) Coil in the normal state and LK8 allows selection of the watchdog relay contact to N/O or N/C

Time Synchronisation

Internal Time Synchronisation

The P925TS-X Interface Card generates a time sync pulse, which is broadcast to all of the associated I/O Cards in the system as a common time base.

External Time Synchronisation

If preferred the 9000TS can be synchronised to an external time source such as IRIG-B or GPS

The P925TS-X Interface Card is equipped with a three-way header and two-way shorting bar, which allows the user to select whether the time synchronisation pulses are via internal or external sources.

Shorting bar LK4 is used to set the required time synchronisation path as shown below.

Time Synchronisation Jumper Setting

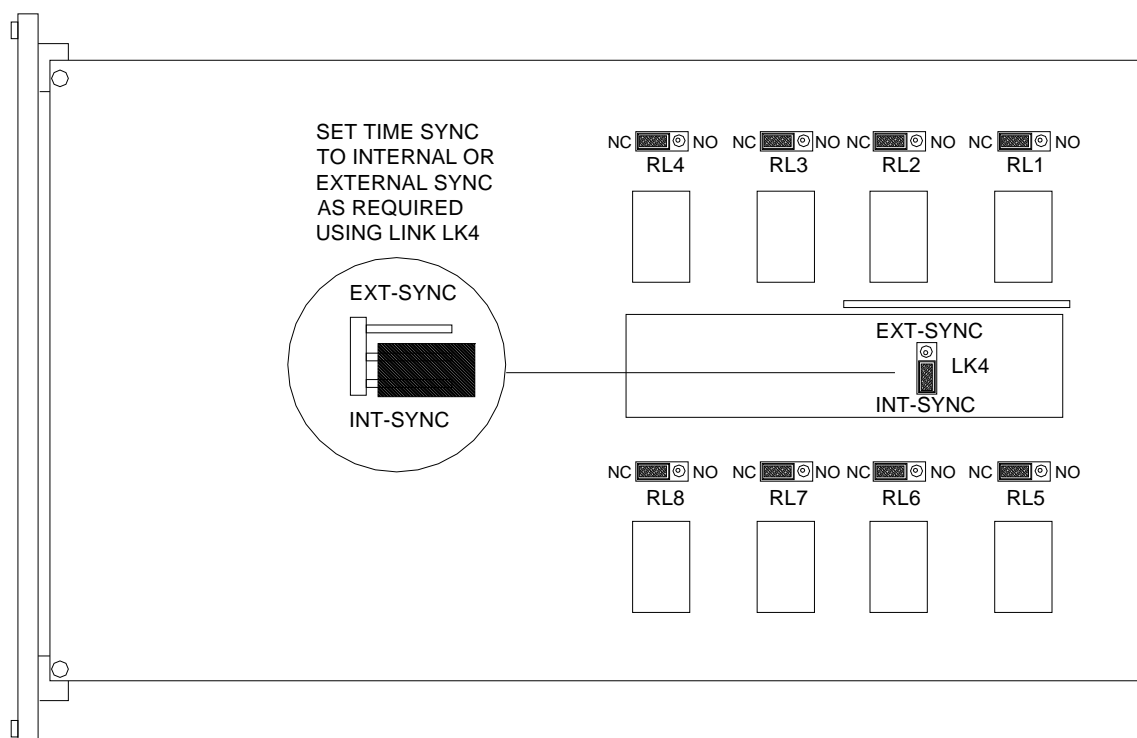

Interface Card Relay Outputs.

All 9000TS Systems are equipped with eight common relays plus one watchdog relay as typically shown below.

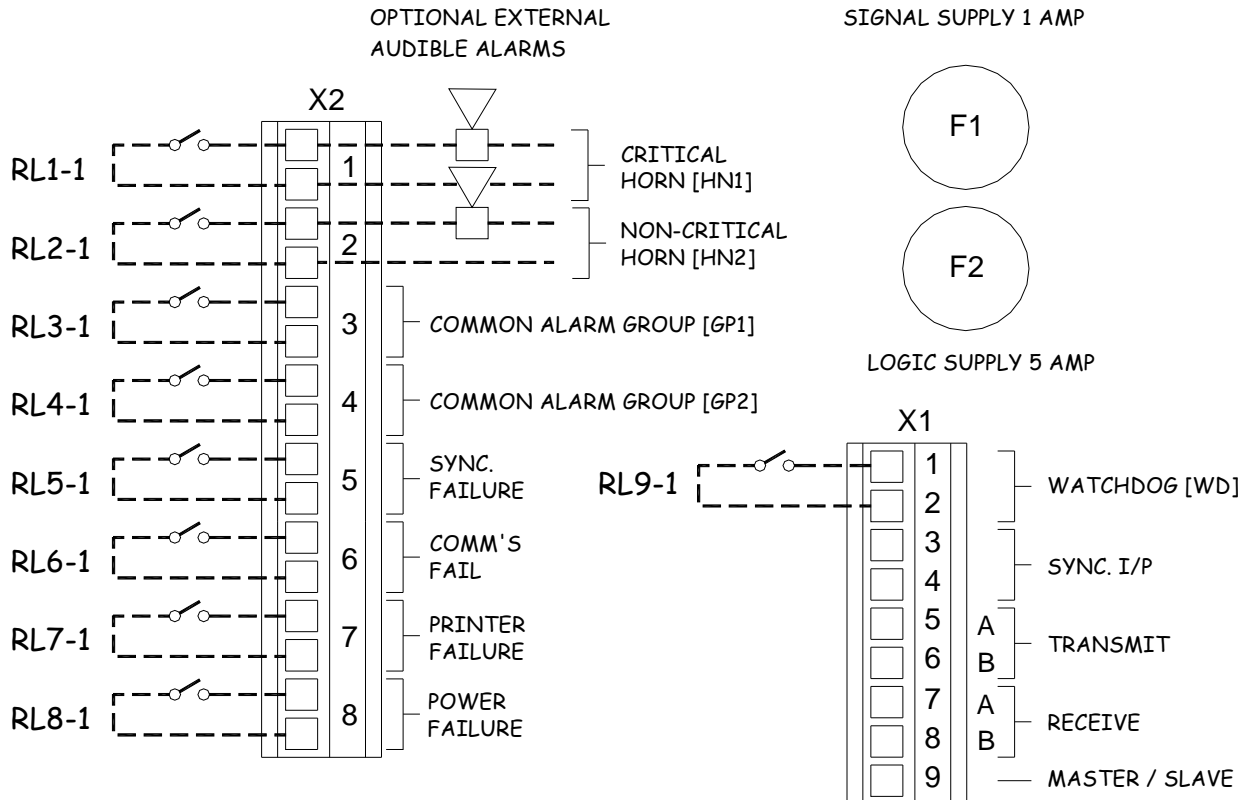

Note:-

- RL1 and RL2 are factory set as horn relays
- RL3 and RL4 are factory set as Group Relay 1 and 2
- RL5 to RL8 are software configurable for use as group, horn or fault monitoring relays. The functions shown for RL5 - RL8 are therefore shown as typical examples only.
- RL9 is factory set as a watchdog relay which will change state if any faults are detected within the system. The Relay can be set to EN or DE-EN using Link LK6 and the Contact state can be set to N/O or N/C using Link LK8 as required.

System Relay Settings:-

Setting Relay Contact States

Links LK1 to LK8 on the P925TS-X Interface Card allow the user to select the non-alarm state of each of the relays.

The relay contact can be set to be either normally open (NO) or normally closed (NC) using a 2 way shorting bar on a 3 pin header as detailed in the diagram below.

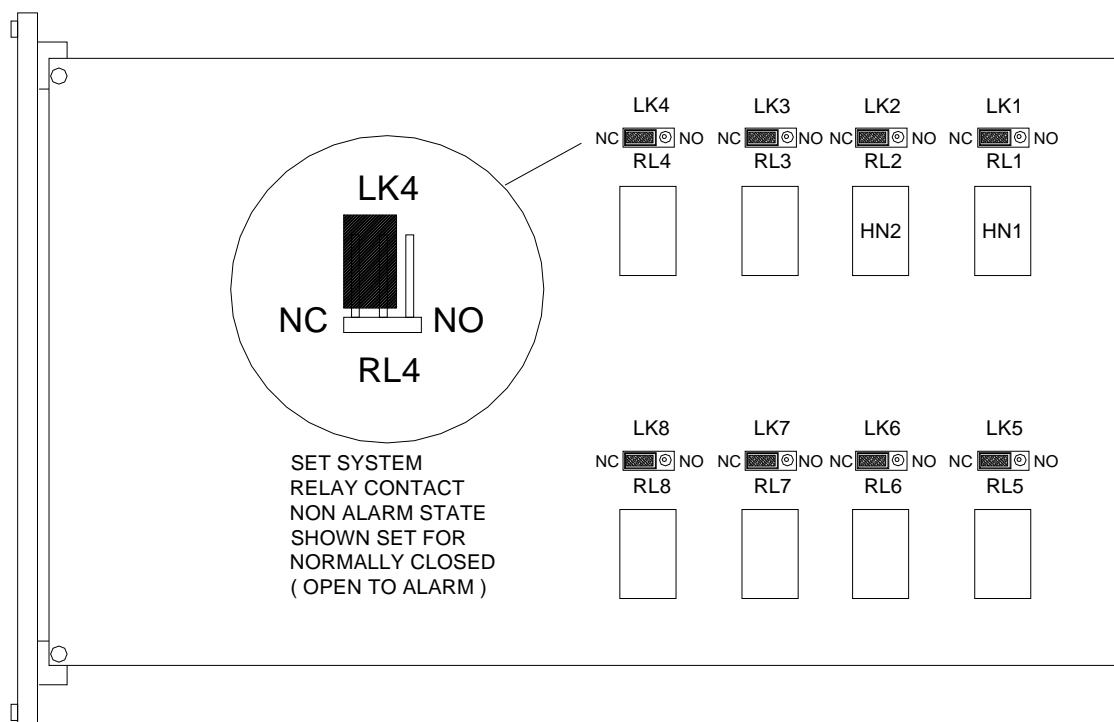

P925TS-X Interface Card:- System Relay – “Non Alarm” Contact State Setting

Horn Relay:- RL1

RL1 is factory set as a critical horn relay. This relay will change state when any channel software configured to operate Horn A (HA) activates and the relay will remain in the abnormal state until the mute or acknowledge pushbutton has been pressed.

Coil Setting (Non-alarm state)

RELAY	SWITCH	STATE	FUNCTION
RL1	SW1-1	OFF	De-energised
		ON	Energised

Horn Relay:- RL2

RL2 is factory set as a non critical horn relay. This relay will change state when any channel software configured to operate Horn B (HB) activates and the relay will remain in the abnormal state until the mute or acknowledge pushbutton has been pressed.

Coil Setting (Non-alarm state)

RELAY	SWITCH	STATE	FUNCTION
RL2	SW1-2	OFF	De-energised
		ON	Energised

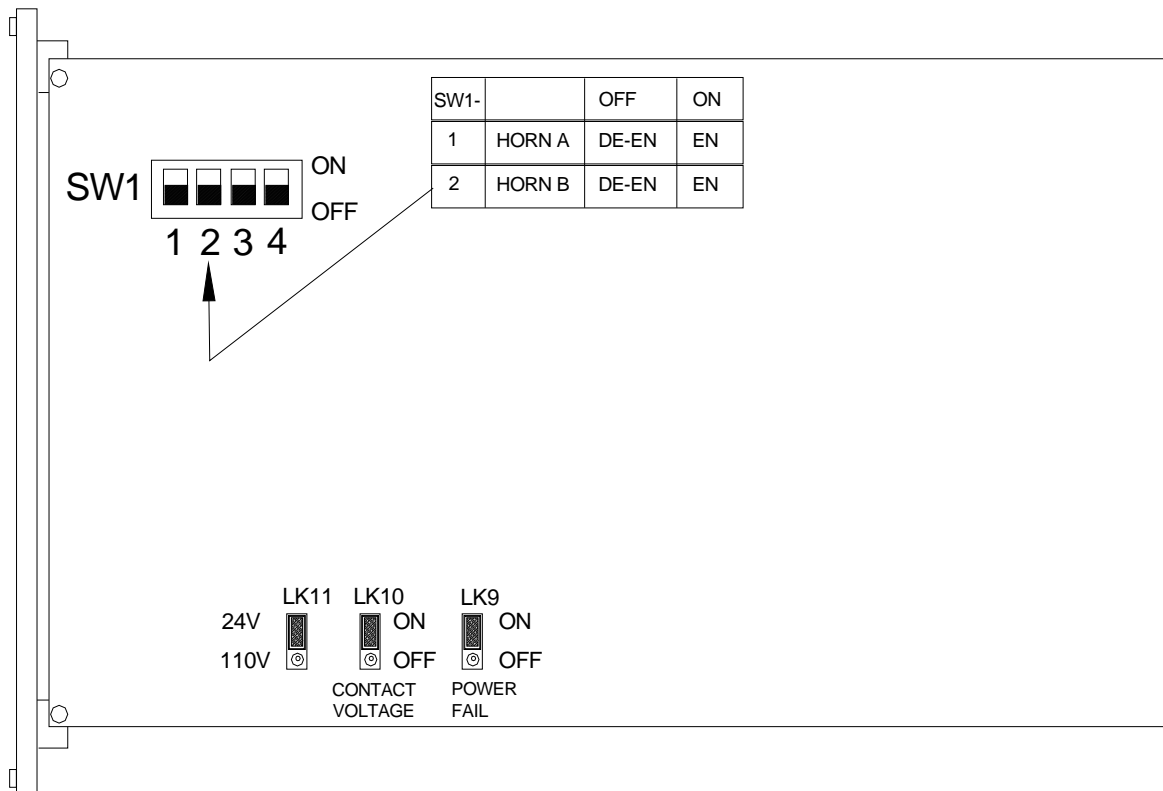

Group Relays RL3 & RL4:-

RL3 and RL4 are factory set to operate as group 1 and group 2 common alarm relays.

When an alarm occurs on any within the group the associated relay will change state and the relay will remain in the abnormal state until the fault has been cleared and the alarm has been reset.

The coil state of RL3 and RL4 can be set to normally energised or normally de-energised using switch SW1 positions 3 and 4 on the P925TS-X Interface Cards as detailed below

Coil Setting (Non-alarm state)

RELAY	SWITCH	STATE	FUNCTION
RL3	SW1-3	OFF	De-energised
		ON	Energised
RL4	SW1-4	OFF	De-energised
		ON	Energised

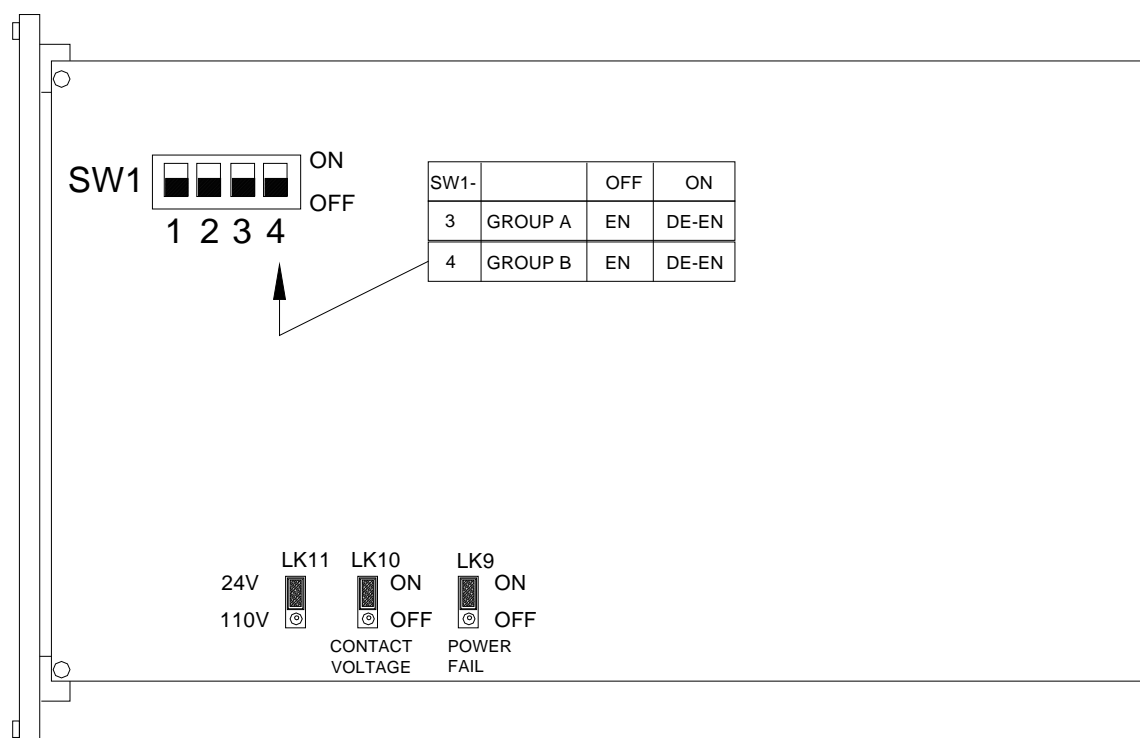

Relays RL5 - RL8:-

RL5 - RL8 are factory supplied as normally energised relays and any relay can be software configured to one of the following functions

Group Relay 1 – 6

Any channel configured to the associated group will de-energise the relay on alarm and the relay will remain in the abnormal state until the alarm has been cleared and re-set

Group Relay 1 - 6 with reflash function added

Additional HA or HB Horn relay

Combined HA & HB Horn relay

Internal fault

Printer fault

Log fault

GPS fault

Sync. fault

Reflash Common Alarm Relays

Group relays can be software configured to allow the associated relay contacts to drop out and re-alarm, reflash, if additional alarms occur in the same group whilst the Relay is already in the alarm state.

Power Failure Monitoring:-_PF

RL5 can be configured to monitor the 24VDC logic supply and/or signal supply.

The relay will de-energise if the associated supply fails. Links LK9, LK10 and LK11 are provided on the P925TS-X Interface Card to allow the user to select: -

LINK	POSITION	FUNCTION
LK9	ON	Loss of the 24VDC logic supply will de-energise the relay.
	OFF	Disabled
LK10	ON	Loss of the signal supply will de-energise the relay.
	OFF	Disabled
LK11	ON	Signal Supply Monitoring level is set to 24V AC/DC
	OFF	Signal supply Monitoring level is set to 110V AC/DC

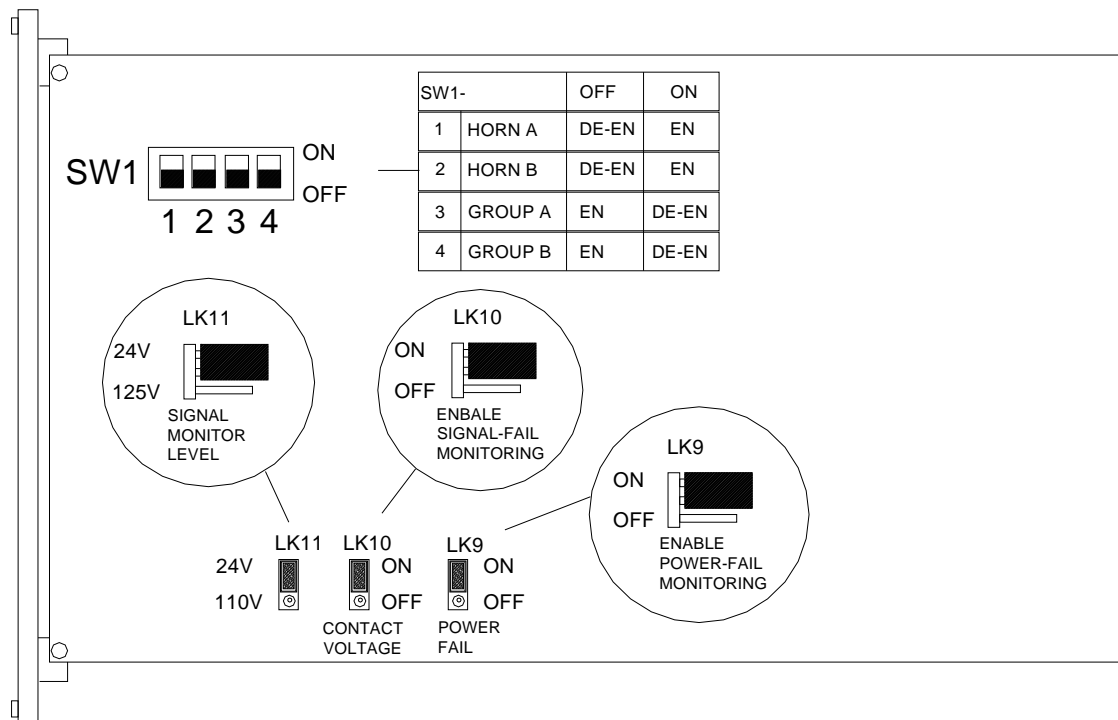

Printer Failure Alarm

System relays RL3 - RL8 can be software configured to operate in the event of a printer failure alarm being received by the 9000TS System.

Time Sync. Failure

System relays RL3 - RL8 can be software configured to operate in the event of a time sync. error signal being generated by the 9000TS System

Buffer Overload Alarm

System relays RL3 - RL8 can be software configured to operate in the event of a buffer overload signal being generated by the 9000TS System

Watchdog Relay:- WD

RL9 is factory set as a watchdog relay

The relay is normally de-energised and will energise if the system detects a fault. The relay will automatically reset when the fault condition has been removed. The coil state can be changed from normally DE-EN to normally EN using Link LK6 and the contact state can be set to N/O or N/C using Link LK8 as required.

Customer terminals are available on the rear of the rack as shown in the diagram below.

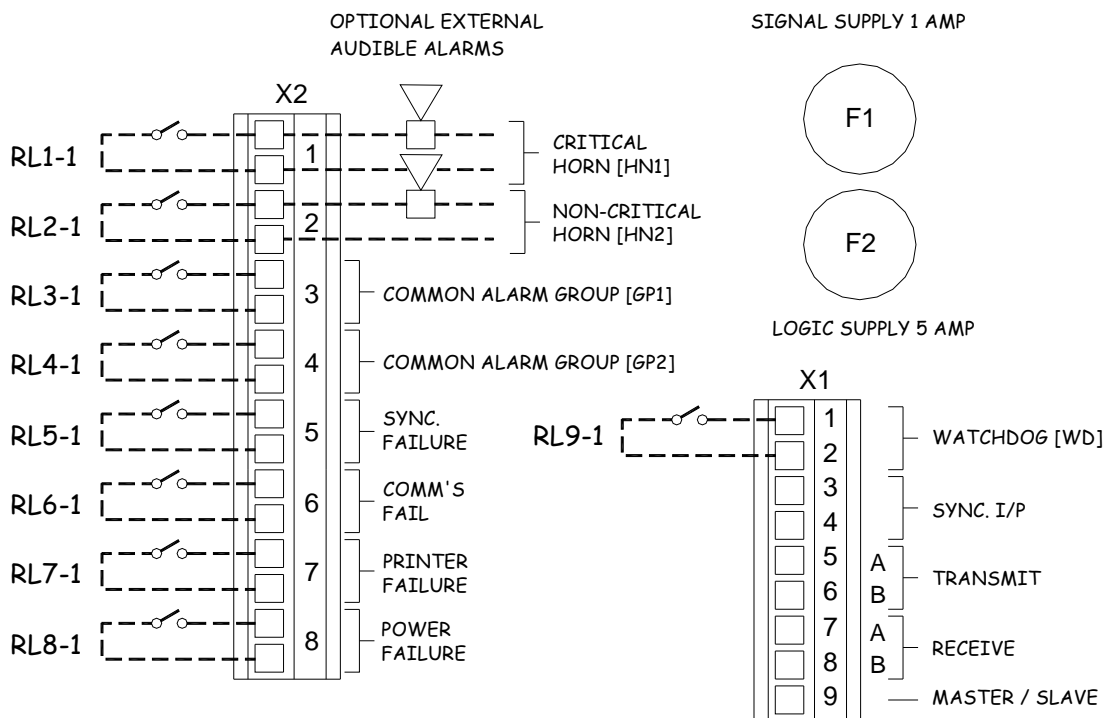

SECTION 7A – P925TS-X1/2 DUAL REDUNDANT INTERFACE CARD

Dual Interface Card Features

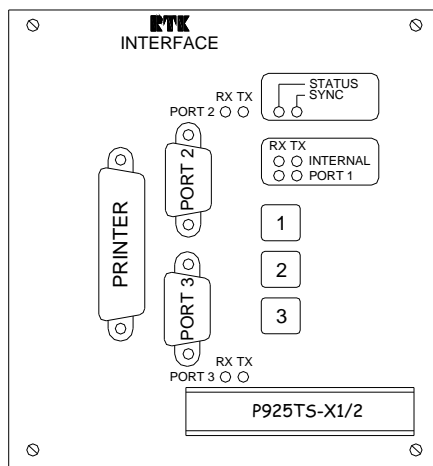

The purpose of this section is to describe the differences between the standard interface card as described above and the dual redundant interface card. All other functionality is assumed to be the same.

Diagnostic LED's

LED	FUNCTION
STATUS	Master status - illuminated indicates internal comms port 0 control.
SYNC	Time Sync – Flash rate of 1 pulse/sec ok

Dual Redundant System

A Dual Redundant system has two interface cards. The system is intended to provide a secondary interface card in the event of a failure associated with the primary interface card. When no fault exists the customer ports 1, 2, and 3 on both cards provide the same contact and alarm data. Internal events data may be different since this is card specific.

Dominant X1 and Submissive X2

There are two types of dual redundant interface card Dominant and Submissive, Identified on the front handle by the letters X1 and X2 respectively. Selection of these two card types is via a single link LK7 on the PC104 card within the interface card module.

Dominant LK7 Not Fitted.

Submissive LK7 Fitted.

Dominant and Submissive cards communicate with each other via “Port 4” three terminal connector on the front face plate, note in later systems this connection maybe internal. It is important that the Dominant and Submissive Port 4 Terminal’s (if fitted) should be connected pin1 to pin1 etc.

Dominant X1 Control Function

During power up the Dominant interface card assumes master mode control of internal communications between interface card and Input and Output cards (Port 0). Control of the internal communications will only be relinquished if certain criteria are met – Refer to Switchover protocol. While the dominant card is a master to Port 0 customer Ports 1, 2 and 3 are fully active .If the card relinquishes control of Port 0 then Port 1 will no-longer respond to AMS requests.

Submissive X2 Control Function

On power up the Submissive card assumes slave mode for Port 0. Submissive master control of the internal communications will only take place if certain criteria are met – Refer to Switchover protocol. Customer Ports 1, 2 and 3 are fully active irrespective of Submissive Port 0 control status.

Switchover Protocol

The transfer of Port 0 control between Dominant and Submissive is defined by a set of rules. The rules which apply differ depending on the quality of Port 4 communications between Dominant and Submissive. If Port 4 status is ok then switchover is based on a customer Port status comparison, else switchover is based on Port 0 status. As a default, switchover is not allowed within 12 seconds of a previous switchover.

Port 4 status ok

Based on a predefined hierarchy port 0 control will be assigned to which ever interface card is considered to have the healthiest Port 1, 2 or 3 status.

The default port comparison hierarchy is as follows:-

Port 1 Most important.

Port 3 |

Port 2 |

Port 6 Least important.

Port 4 status fault

If Port 0 status ok. Port 0 control will remain with Dominant or Submissive.

If Port 0 status fault. Dominant will attempt to take control, if unsuccessful then Submissive will assume control.

Note: Control on power up will always be allocated to the Dominant card first were possible.

Switchover Scenario’s

Table below assume port 4 status ok.

DOM FAILURE MODE	SUB FAILURE MODE	MASTER CONTROL
None	None	No change
Power up	None	Submissive
None	Power up	Dominant
Port 0 fail	None	Submissive
None	Port 0 fail	Dominant
Port 1 fail	Port 1 fail	No change
Port 1 fail	Port 3 fail	Submissive
Port 1 fail	Port 2 fail	Submissive
Port 1 fail	Port 6 fail	Submissive
Port 1 fail	None	Submissive
Port 3 fail	Port 1 fail	Dominant
Port 3 fail	Port 3 fail	No change
Port 3 fail	Port 2 fail	Submissive
Port 3 fail	Port 6 fail	Submissive
Port 3 fail	None	Submissive
Port 2 fail	Port 1 fail	Dominant
Port 2 fail	Port 3 fail	Dominant
Port 2 fail	Port 2 fail	No change
Port 2 fail	Port 6 fail	Submissive
Port 2 fail	None	Submissive
Port 6 fail	Port 1 fail	Dominant
Port 6 fail	Port 3 fail	Dominant
Port 6 fail	Port 2 fail	Dominant
Port 6 fail	Port 6 fail	No change
Port 6 fail	None	Submissive

Table below assume port 4 status fault.

DOM FAILURE MODE	SUB FAILURE MODE	MASTER CONTROL
None	None	No change
Power up	None	Submissive
None	Power up	Dominant
Port 0 fail	None	Submissive
None	Port 0 fail	Dominant
Port 1 fail	Port 1 fail	No change
Port 1 fail	Port 3 fail	No change
Port 1 fail	Port 2 fail	No change
Port 1 fail	Port 6 fail	No change
Port 1 fail	None	No change
Port 3 fail	Port 1 fail	No change
Port 3 fail	Port 3 fail	No change
Port 3 fail	Port 2 fail	No change

Port 3 fail	Port 6 fail	No change
Port 3 fail	None	No change
Port 2 fail	Port 1 fail	No change
Port 2 fail	Port 3 fail	No change
Port 2 fail	Port 2 fail	No change
Port 2 fail	Port 6 fail	No change
Port 2 fail	None	No change
Port 6 fail	Port 1 fail	No change
Port 6 fail	Port 3 fail	No change
Port 6 fail	Port 2 fail	No change
Port 6 fail	Port 6 fail	No change
Port 6 fail	None	No change

Table below lists event type's specific to a dual redundant 9000ts system.

Dual Redundant Specific Event Type's

EVENT TYPE	DESCRIPTION
164	DOM Port 3 serial com OK
165	DOM Port 3 serial com Fail
166	DOM Port 2 serial com OK
167	DOM Port 2 serial com Fail
168	DOM Port 1 serial com OK
169	DOM Port 1 serial com Fail
170	DOM Dualred link OK
171	DOM Dualred link Fail
172	SUB Port 3 serial com OK
173	SUB Port 3 serial com Fail
174	SUB Port 2 serial com OK
175	SUB Port 2 serial com Fail
176	SUB Port 1 serial com OK
177	SUB Port 1 serial com Fail
178	SUB Port 0 serial com OK
179	SUB Port 0 serial com Fail
180	DOM Port 0 serial com OK
181	DOM Port 0 serial com Fail
182	DOM control OK
183	DOM control Fail
184	SUB control OK
185	SUB control Fail
186	SUB DOM Compare Config OK
187	SUB DOM Compare Config Fail
188	DOM SUB Compare Config OK
189	DOM SUB Compare Config Fail

190	SUB Dualred link OK
191	SUB Dualred link Fail

SECTION 8 – INPUTS AND OUTPUTS

Optically Coupled Inputs

All inputs to the 9000TS System are optically coupled to increase the tolerance of the system to noise interference and to allow operation from AC or DC voltage sources.

Digital Inputs

P925TS-I Input Cards are designed to operate from either normally open or normally closed volt free contacts with a fused +24VDC being supplied by the 9000TS System for use as a signal supply voltage.

As an alternative the customer can use 24VDC powered Inputs which connect directly to the associated Input card. If powered inputs are required the OV reference of the customers supply should be connected to the OVC IN terminal on the rear of each chassis as this links the common return path of all of the optically coupled inputs.

As an option higher voltage powered inputs can be used, typically +125VDC, and each channel is equipped with a 3 pin header and 2 way shorting bar which allows the user to set the input to match the required signal supply voltage level.

For example: The standard input card allows selection of 24VAC/DC OR 125VAC/DC and an ***optional card*** is available for systems requiring 48VAC/DC OR 250VAC/DC

As field contacts are often located a long way from the associated logic it is recommended that input cables be run separately from circuits carrying heavy currents or high voltages to minimise the effects of induced voltages. All inputs are provided with transient filters so that low voltage interference is ignored.

Lock In

Each channel can be software configured to capture fleeting alarms or to allow them to automatically return to the off state as soon as the contact returns to normal.

Lamp/LED Outputs

P925TS-O Output Cards, located in the adjacent slot to P925TS-I Input Cards, allow connection to conventional remote mounting lamp / LED displays. Each of the 16 outputs is short circuit protected and capable of driving 160mA @24VDC.

Repeat Relay Option

P925TS-R Repeat Relay Cards provide 16-volt free contact outputs. Each output can be set to normally open or normally closed using 3 way header pins and 2 way shorting bars on a per channel basis as required. The repeat relay feature is typically used to provide an isolated input to 3rd party Scada packages.

Dual Horn Relay

Two of the common relays RL1 and RL2 are factory set as horn relays and these can be used to connect to remote audible devices. The remote audibles are often referred to as priority and non-urgent and provide the operator with distinct tones that help determine the speed of response required.

Group Relays

Six of the common relays can be configured, as group relays and each channel can be set to drive any of these relays. The relays typically provide summary alarm contacts for use by 3rd party devices. An example of this would be alarm groups determined by the alarm type, temperature, pressure, or level.

Reflash Facility

Each of the common group relays can be software configured to reflash every time a new alarm occurs within the same group, which allows the associated contacts to return to normal for approx 500ms and then return to the alarm state.

Fault Relays

Any of the common relays can be configured to provide volt free contact outputs which will change state in the event of a printer fault or primary event buffer overflow.

Watchdog Relay

Each 9000TS System is equipped with a watchdog relay as standard and this relay will activate in the event of an internal error or communication failure.

RS485 Communication Option

A modbus communication port, Port 1, is provided on the front of the P925TS-X Interface Card to allow 3rd party data to be transmitted to 3rd party devices if required.

RS232 Printer Port

A standard 25 pin printer port is provided on the front of the P925TS-X Interface Card to allow direct connection to a suitable dot matrix printer for dynamic printing of events as they occur.

RS232 Programming Port

A 9 pin programming port, Port 2 is provided on the front of the P925TS-X Interface Card to allow the system to be programmed using the RTK supplied windows style software utility and a suitable lap top computer or PC.

Control Inputs

Any digital input channel can be configured to operate as a pushbutton input to provide control of the associated lamp / LED outputs. The input can be configured for use as Lamp Test, System Test, Silence, Acknowledge, Reset, First Reset, Lamp & Audible Test or as a Sleep Mode control input.

Group Inhibits

Each system is provided with eight inhibit groups which allows the user to configure multiple digital inputs to each group to inhibit the alarms during prolonged maintenance periods.

Once an inhibit group has been formed any spare input channel can be configured as the inhibit group control input and a remote inhibit switch can be used to inhibit all of the alarms within the group as required.

Data Storage

The P925TS-X interface card stores configuration data for all cards in the system.

Once a 9000TS System has been configured the user can replace any Input, Output or Relay Card and all of the settings for the new card will be automatically updated with the settings from the original card using stored configuration data held within the P925TS-X interface card.

RTK strongly recommend that all configurations be saved to a separate source as a back up before any alterations to the system are made.

The 9000TS system is designed for safety critical applications therefore all card types are designed to be removed and re-inserted in the rack with power applied to ensure that the remaining system continues to monitor during this phase.

Although the P925TS-X Interface Card stores configuration data for the associated I/O cards the same data is also stored locally on the individual cards allowing the alarm system to continue to operate as a conventional annunciator even if the P925TS-X Interface Card is removed.

SECTION 9 – P925TS-I INPUT CARD

The P925TS-I Input Card is capable of accepting sixteen digital inputs and is equipped with a micro-controller and EEPROM, which allows configuration details to be stored in non-volatile memory. No battery backup is required to maintain this memory and system configuration can be changed tens of thousands of times without degradation.

All inputs are optically coupled to ensure maximum reliability in harsh electrical environments, however as field contacts are often great distances from the annunciator it is still advisable to run the contact cables separately from circuits carrying heavy currents and/or high voltages to minimise the effects of induced voltages from these cables. A transient filter is built into the input circuitry so that low voltage interference will be ignored.

Voltage inputs can also be used if the OVS of the 9000TS is linked to the OV of the direct voltage supply to provide a common reference.

Normally open or normally closed continuous or fleeting contacts can be used and the input can be software configured to capture events within the range 1 to 65,000 mS

Signal Input Voltage Selection

The P925TS-I Input Card is suitable for operation from either 24VAC/DC or 125VAC/DC switched or powered inputs. Each card is equipped with shorting links LK1 to LK16, which allows the user to select the associated field input voltage for each channel. In standard applications +24VDC is derived from the P925TS-X Interface Card for use as a signal supply voltage but it is possible to use external voltage sources if required.

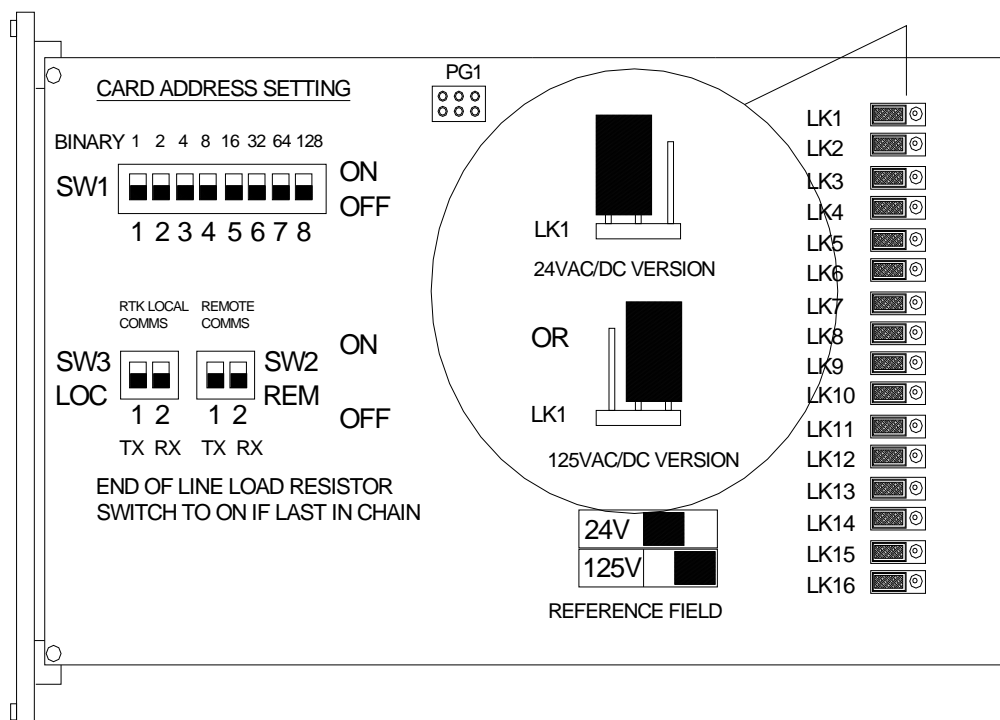

Optional High Voltage Inputs

As an option the P925TS-I Input Card can be supplied suitable for operation from either 48VAC/DC or 250VAC/DC switched or powered inputs. Each card is equipped with shorting links LK1 to LK16, which allows the user to select the associated field input voltage for each channel. In these applications the signal supply voltage must be provided via an external source.

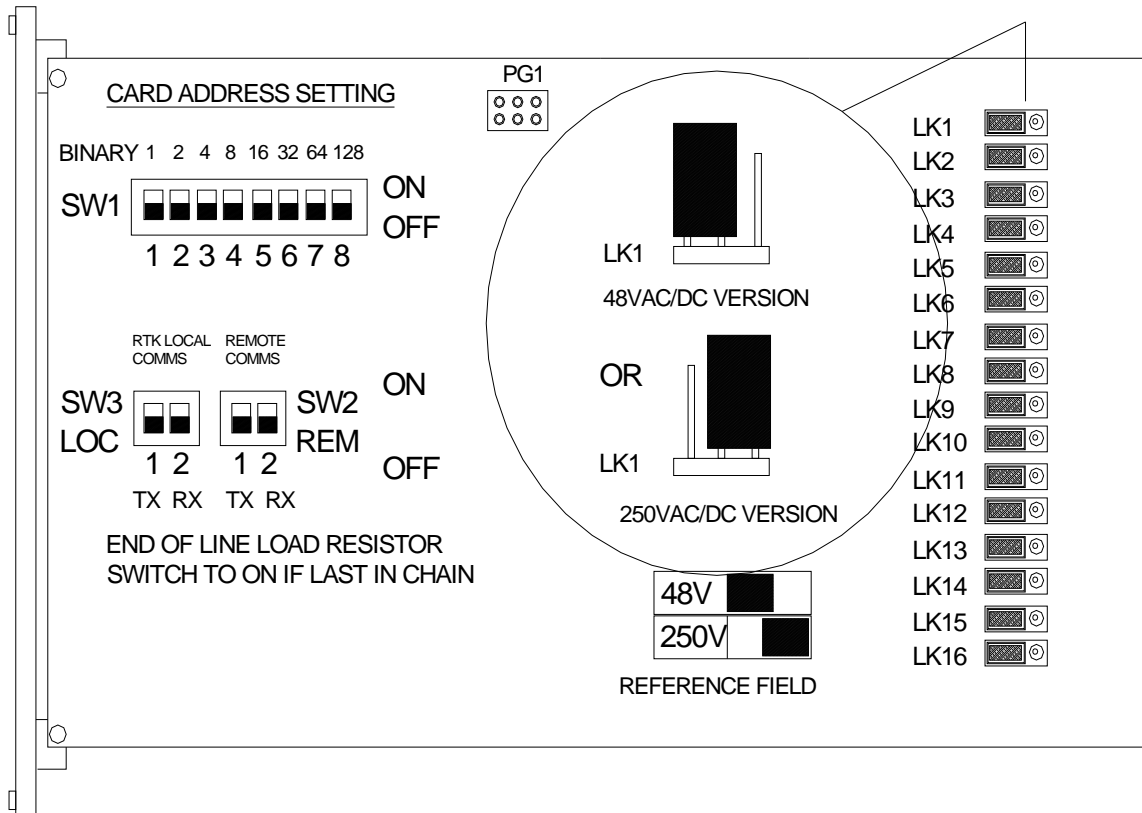

Power on / Status LED

Each Card is supplied with a single green status LED on the front panel.

The LED would be on in the normal state to indicate that the card is powered and there is no fault within the card.

If the user presses the status pushbutton (recessed below the status LED) the Status LED will flash for a short period of time while the Inputs contact state is being checked.

If the unit is incorrectly powered down the status LED will flash until the buffers have been reset.

Alarm Status LED's

Each card is equipped with sixteen yellow LED's, which indicates if any of the associated signal inputs are in the normal or abnormal alarm state as a diagnostic aid and would operate as follows:-

INPUT SET FOR	SIGNAL CONTACT	LED
Normally Open	Open	OFF
	Closed	ON
Normally Closed	Closed	OFF
	Open	ON

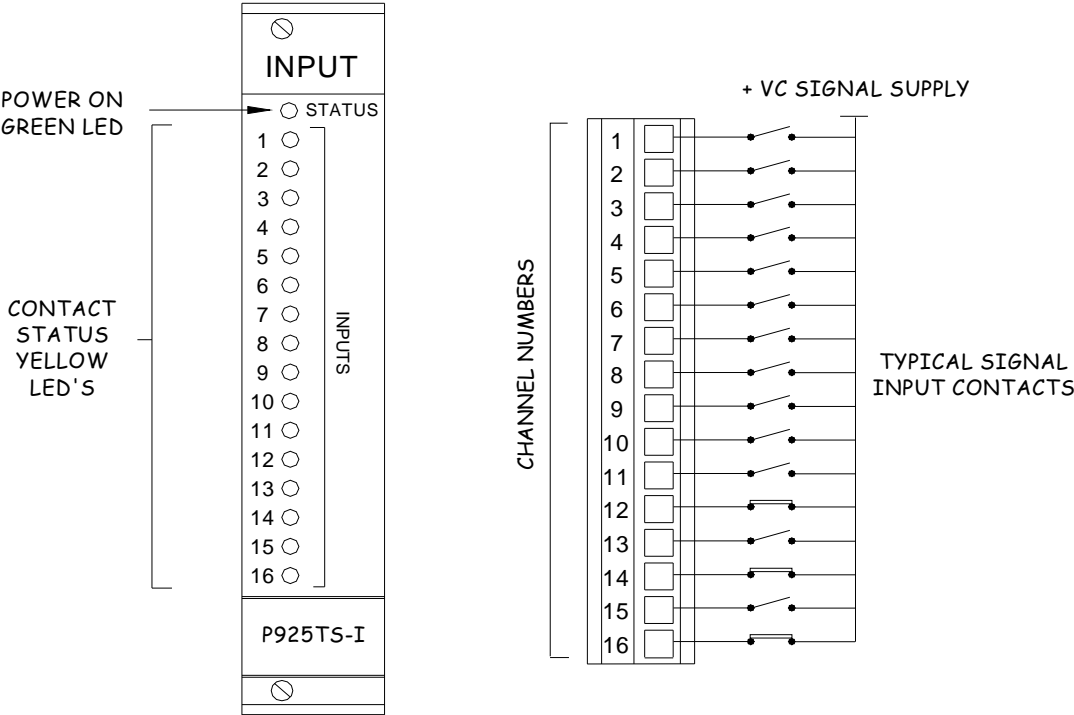

Input Card Face Plate & Wiring

Pushbutton Connections

Any channel can be configured as a pushbutton control input to allow the operator to control the operational sequence if the input card is being used with P925TS-O Output Cards.

There are seven pushbutton control inputs available:- Lamp Test, Acknowledge, Reset, Silence, System Test, First Up Reset and Combined Lamp/Audible Test. Pushbuttons connected to the associated Input should be of the momentary, non-maintained, type with one Normally Open contact per pushbutton.

The common return of the pushbuttons is normally +24VDC however as pushbuttons use standard digital input channels the common return will always be at the same voltage level as the alarm inputs (24VDC as standard optionally 48VAC/DC, 125VAC/DC or 250VAC/DC).

Example:- A system that requires Test, Acknowledge and Reset Pushbuttons would be factory supplied with pushbutton inputs available on channel 14, 15 & 16 on the last P925TS-I Input Card within the system,.

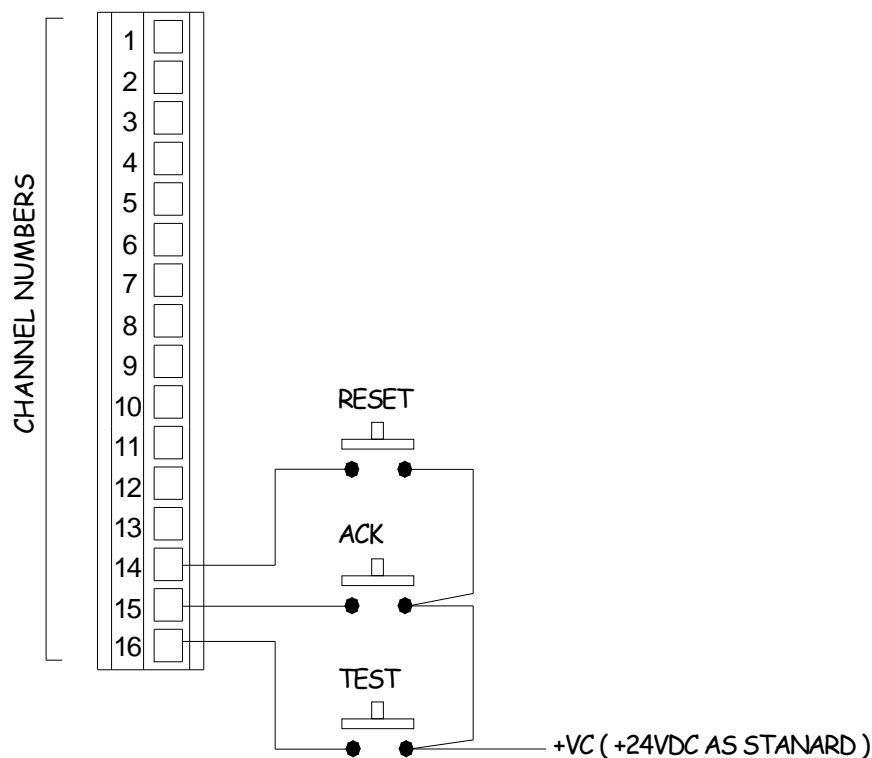

P925TS-I Input Card – Typical Pushbutton Wiring

Please note if a P925TS-O Output Card is located in the adjacent slot to a P925TS-I Input Card with channels wired as pushbutton inputs the associated outputs would only be active when the pushbutton is pressed.

SECTION 10 – P925TS-O OUTPUT CARD

The P925TS-O Output Card is equipped with sixteen open collector outputs each capable of providing 160mA @ 24vdc which can be connected to lamp / LED displays as required.

The output of each channel sinks to OV on alarm and therefore +24VDC is used a common return for all Lamp / LED outputs.

Lamp Protection

During installation and commissioning or as a result of filament failure a short circuit may occur in the output drive causing excessive current to flow in the lamp driving circuit.

The 9000TS System is equipped with automatic electronic crowbars, which will protect the output circuit if excessive current is drawn. If the output fails to operate in the correct manner the drive circuit is turned off and will periodically attempt to automatically recover until the fault has been removed.

Output Drive Type

Each of the sixteen output channels is capable of driving either conventional filament lamps or LED's.

When used with filament lamps the individual output drives pass a small current to each remotely wired lamp to prevent large inrush currents and thermal shock during lamp test.

In applications that require LED's the "keep alive" current must be disabled in software on a per channel basis to prevent the LED's from illuminating at approx 40% of normal brightness during the off cycle.

Card Address Settings

A P925TS-O Output Card is located to the right of the associated P925TS-I Input Card each pair of cards must have the same address. i.e. If the 1st input card in the system is set to address 0 the 1st output card must be set to 0 for the cards to function as a linked pair.

Power On / Status LED

Each Card is supplied with a single green status LED on the front panel.

The LED would be on in the normal state to indicate that the card is powered and there is no fault within the card.

If a card fault is detected the LED will go to off

Lamp / LED Output Status LED

Each card is equipped with 16 x Red LED's, which will operate as a slave of the associated lamp / LED output drive.

The LED will therefore be off, flashing or steady in accordance with the configured alarm sequence. As remote displays are often mounted several meters from the associated display the LED's can be used during commissioning / faultfinding to verify that the output is functioning correctly at the local rack.

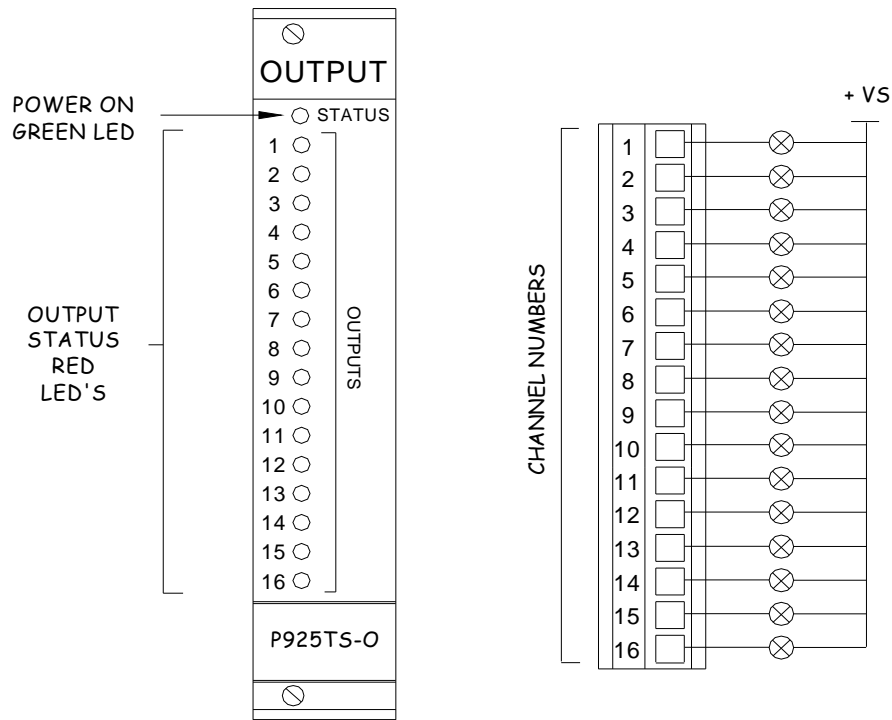

Output Card Face Plate & Wiring

SECTION 11 – P925TS-R RELAY CARD

P925TS-R Relay Card

In applications that require a dedicated repeat relay to be provided on a per channel basis P925TS-R (16) channel relay cards can be added alongside P925TS-I Input or P925TS-O output cards as required.

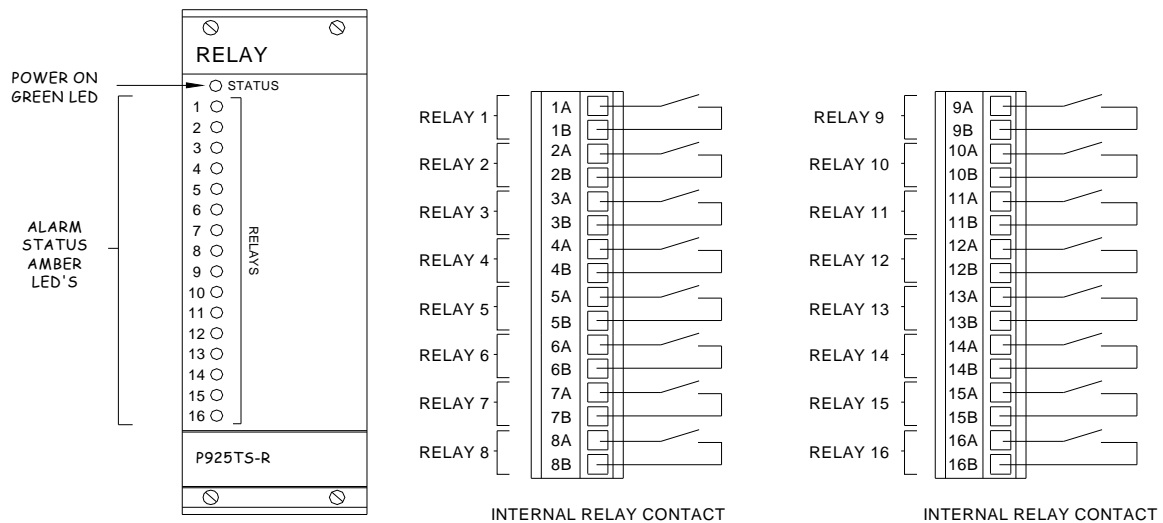

P925TS-R Relay Card

Status LED

Each P925TS-R relay card is supplied with a single green status LED as shown above. The green LED will be ON in the normal state to indicate that the card is powered and no internal card faults have been detected.

Relay Status LED's

Each P925TS-R relay card is equipped with 16 x amber status LED's, which monitor the alarm state of each relay.

Alarm State	Coil Setting	Status LED
Normal	De-Energised	OFF
Abnormal	Energised	ON

OR

Alarm State	Coil Setting	Status LED
Normal	Energised	OFF
Abnormal	De-Energised	ON

Operating Mode:-

The operating mode of each P925TS-R relay card can be configured to operate as:-

- **Input Follower**

P925TS-R relay cards set to this mode will activate when the signal input is abnormal and will return to normal as soon as the input returns to the non alarm state.

OR

- **Logic Follower**

P925TS-R relay cards set to this mode will activate when the signal input is abnormal and will remain active until the alarm input has returned to normal and the operator has cleared the alarm using the pushbuttons associated with the configured alarm sequence.

Switch SW3 Positions 1 and 2 on the lower card are used to set the relay function:-

SW3-1	SW3-2	Function
ON	OFF	Relays follow the Input
OFF	ON	Relays follow the alarm

The finished P925TS-R assembly comprises 2 x (8) channel relay cards with a common face plate.

The lower card, part no CB5507POP, provides the first 8 x relays as shown below:-

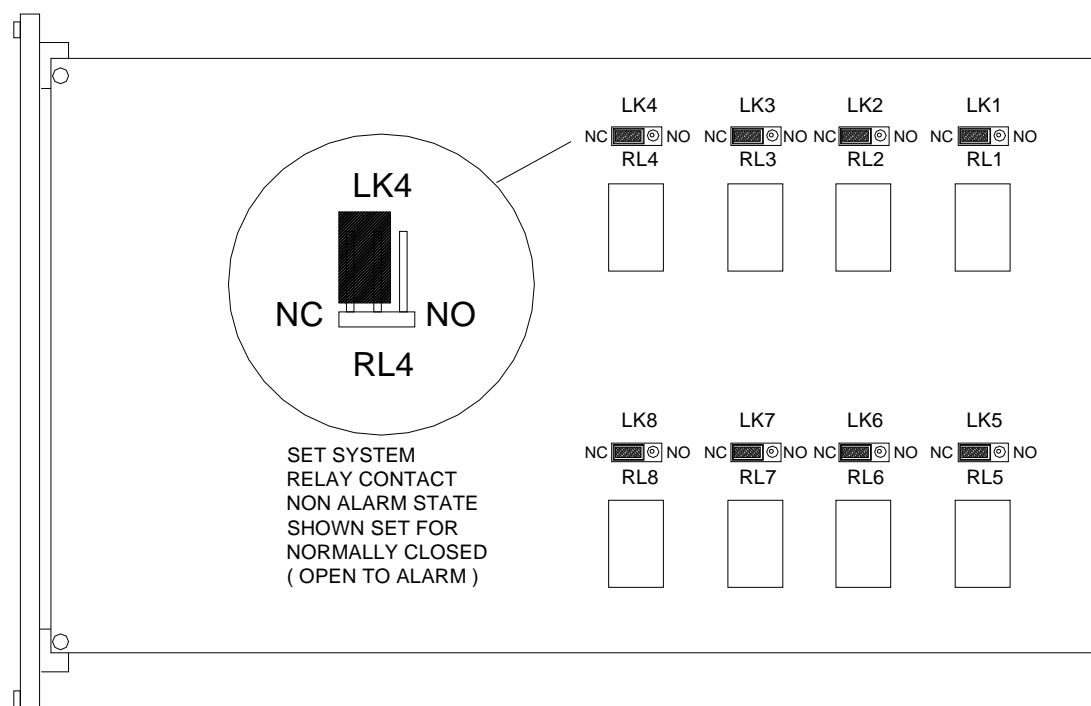

The upper card, part no CB5488POP, provides an additional 8 x relays as shown below:-

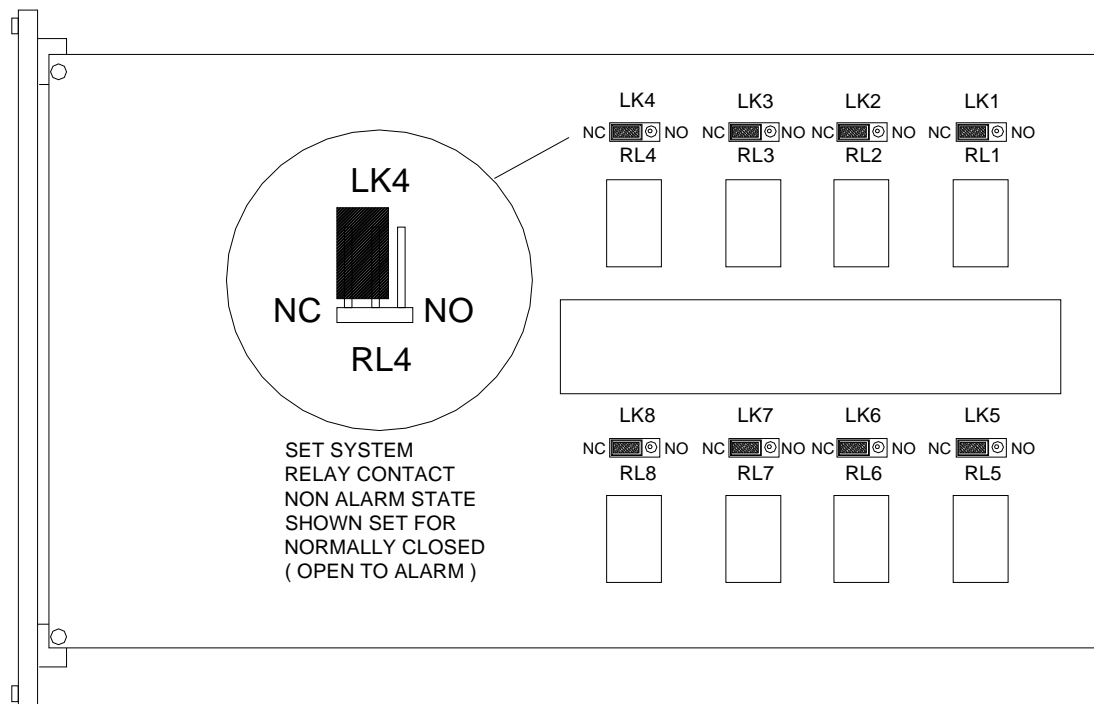
**Contact State:-**

Each of the 16 x relays is equipped with 1 x changeover contact and the user can select the non alarm state of each relay to Normally Open or Normally Closed using a 3 way header and 2 way shorting bar.

In the example shown above Relay 4 has been set to Normally Closed

Coil State:-

The non alarm coil state of each P925TS-R relay card can be configured to:-

- Normally energised (de-energised on alarm)

OR

- Normally de-energised (energised on alarm)

Switch SW3 position 3 on the lower card is used to set the non alarm coil state

SW3-3	Function
OFF	Normally De-Energised
ON	Normally Energised

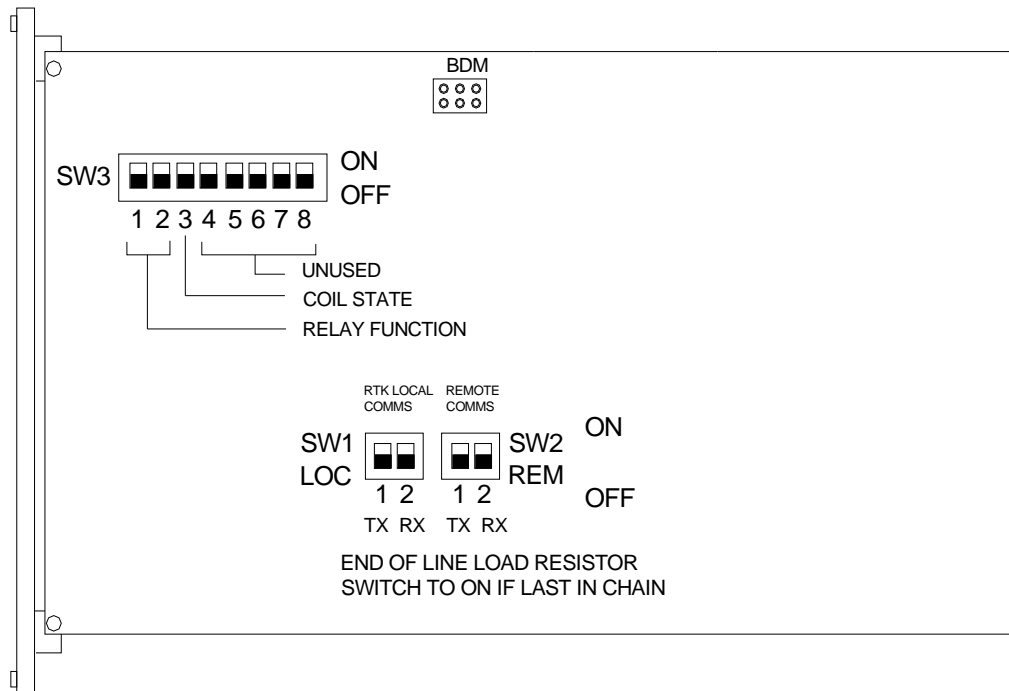

P925TS-R Relay Card (lower board part no CB5507POP) switch locations

Switch SW3 positions 1 and 2 are used to set the relay function

Switch SW3 position 3 is used to set the relays to energised or de-energised

Switch SW3 positions 4 to 8 are not used

Switch SW1 and SW2 are used to set the end of line resistors if the P925TS-R is the last card in the system.

SECTION 12 – LOGIC AND SIGNAL POWER OPTIONS

Standard Systems Using 24VDC Logic And Signal Power

If the system derives its power from a source that is higher than 24VDC an external AC/DC or DC/DC power supply unit must be used to convert the incoming supply voltage into the required 24VDC logic supply.

Logic Supply

The 24VDC logic supply should be connected to the terminals marked +VS and 0VS on the logic rack. The logic supply is protected with a 5A Fuse (F2) and a monitor LED is provided to indicate the status of the fuse.

Signal Supply

Standard 9000TS Systems provide +24VDC as a signal supply voltage which is derived from the logic supply on the P925TS-X Interface Card.

The 24VDC logic supply outputs +VS and OVS are wired into the signal supply input terminals marked +VC IN and OVC IN.

The signal supply voltage, (+24VDC), is available on terminal +VC OUT for distribution to the customers signal input contacts. The signal supply output is protected with a 1A fuse (F1) and a monitor LED is provided to indicate the status of the fuse.

Please note:- Each P925TS-I Input Card is equipped with a 3 pin header and 2 way shorting bar that allows selection of inputs suitable for operation from 24VAC/DC or 125VAC/DC. Please ensure the jumper is in the correct position before applying power.

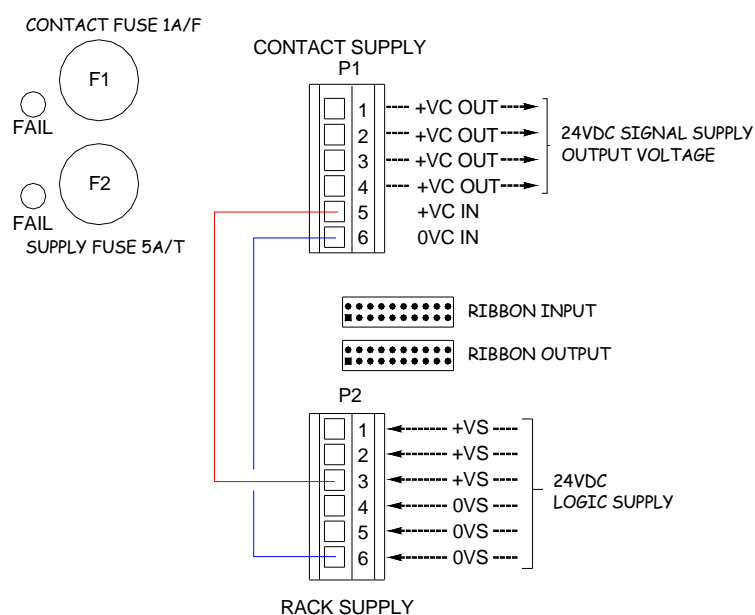

24VDC Combined Logic / Signal Input Power Wiring

Optional Isolated 24VDC Signal Input Power

In situations of extreme electrical noise, it may be preferable to power the alarm logic and signal inputs from separate isolated power supplies. This will significantly reduce any disturbance due to large currents flowing in the common supply lines. Systems using isolated 24VDC logic and 24VDC signal supplies should be connected as follows:-

Logic Supply

The 24VDC logic supply should be connected to the terminals marked +VS and 0VS on the logic rack. The logic supply is protected with a 5A fuse (F2) and a monitor LED is provided to indicate the status of the fuse.

Signal Supply

The 24VDC signal supply should be connected to the signal supply input terminals marked +VC IN and OVC IN, this input is filtered and protected with a 1A fuse (F1) and a monitor LED is provided to indicate the status of the fuse.

The signal supply voltage, (+24VDC), is available on terminal +VC OUT for distribution to the associated signal input contacts.

Please Note: - Each P925TS-I Input Card is equipped with a 3 pin header and 2 way shorting bar that allow selection of inputs suitable for operation from 24VAC/DC or 125VAC/DC. Please ensure the jumper is in the correct position before applying power.

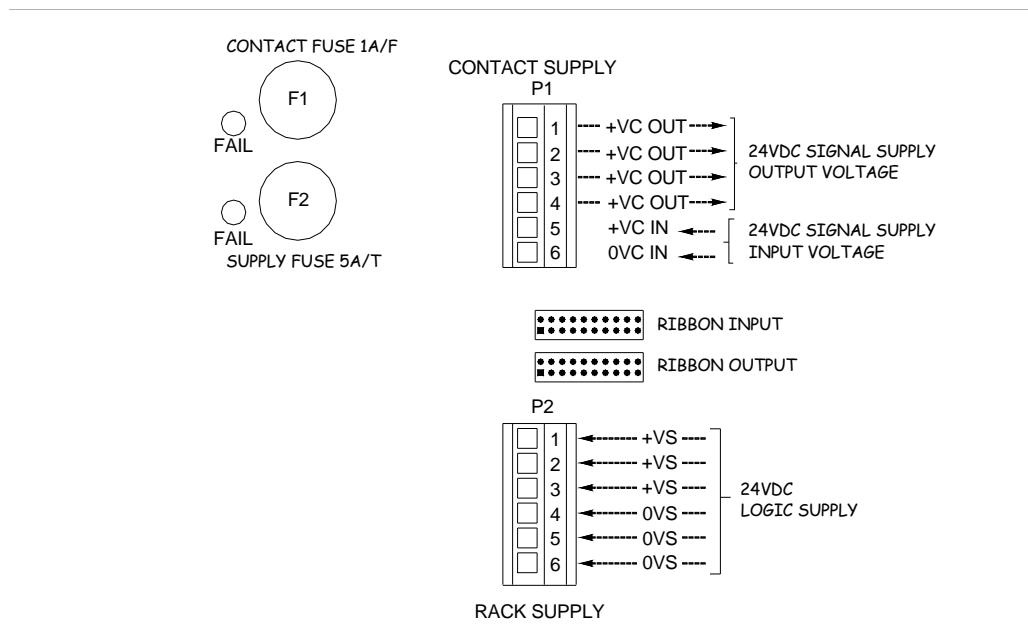

24VDC Logic and Isolated 24VDC Signal Input Power Wiring

Optional 125VAC/DC High Voltage Signal Inputs

Systems using isolated 24VDC logic and H.V. 125VAC/DC signal supplies should be connected as follows:-

Logic Supply

The 24VDC logic supply should be connected to the terminals marked +VS and 0VS on the logic rack. The logic is protected with a 5A fuse (F2) and a monitor LED is provided to indicate the status of the fuse.

Signal Supply

The high voltage 125VAC/DC signal supply should be connected to the signal supply input terminals marked +VC IN and OVC IN, this input is filtered and protected with a 1A fuse (F1) and a monitor LED is provided to indicate the status of the fuse.

The high voltage signal supply voltage (+125VAC/DC) is available on terminal +VC OUT for distribution to the associated signal input contacts.

Caution:- High voltages will be present on all of the signal input circuits when the associated contacts are in the closed position.

Please note- Each P925TS-I Input Card is equipped with a 3 pin header and 2 way shorting bar that allows selection of inputs suitable for operation from 24VAC/DC or 125VAC/DC. Please ensure the jumper is in the correct position before applying power.

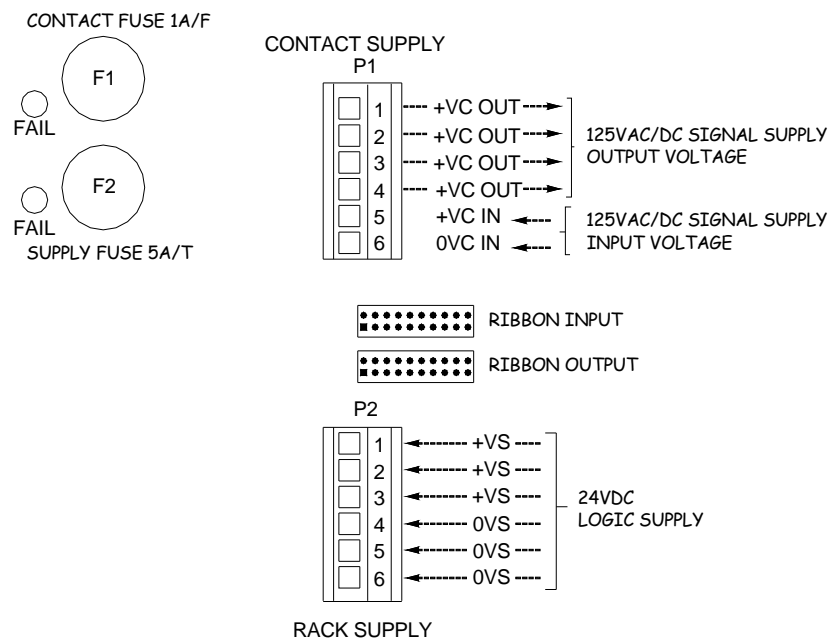

24VDC Logic and Isolated 125VAC / DC Signal Input Power Wiring

Optional 48 or 250VAC/DC High Voltage Signal Inputs

Systems using isolated 24VDC logic and optional H.V. signal supplies should be connected as follows:-

Logic Supply

The 24VDC logic supply should be connected to the terminals marked +VS and 0VS on the logic rack. The logic is protected with a 5A fuse (F2) mounted on the rear of the 19" rack and a monitor LED is provided to indicate the status of the fuse.

Signal Supply

The high voltage signal supply, (+48 or 250VAC/DC), should be connected to the signal supply input terminals marked +VC in and OVC, this input is filtered and protected with a 1A fuse (F1) and a monitor LED is provided to indicate the status of the fuse.

The high voltage signal supply, (+48 or 250VAC/DC), is available on terminal +VC OUT for distribution to the associated signal input contacts.

Caution:- High voltages will be present on all of the signal input circuits when the associated contacts are in the closed position.

Please note- Each P925TS-I Input Card is equipped with a 3 pin header and 2 way shorting bar that allows selection of inputs suitable for operation from 48VAC/DC or 250VAC/DC. Please ensure the jumper is in the correct position before applying power.

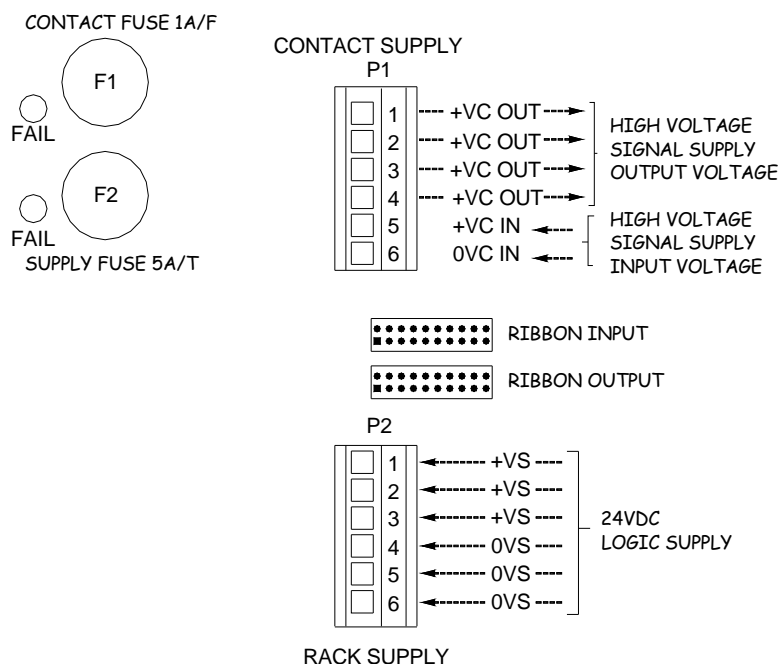

24VDC Logic and Isolated High Voltage Signal Input Power Wiring

SECTION 13 – CARD ADDRESS SETTINGS

Each card in the system must be set to a unique address using switch SW1 position 1 to 8, which is located in the top left hand corner of the associated P925TS-I input Card, P925TS-O Output Card. The first P925TS-I Input Card in the system is normally set to address 0 (All SW1-* switches off) and the remaining cards should be set according to card type as follows:-

9000TS systems equipped with P925TS-I Input Cards each card is set to its own unique address

9000TS systems equipped with P925TS-I Input Cards and P925TS-O Output Cards each pair of input and output cards needs to be set to the same address.

9000TS systems equipped with P925TS-I Input Cards, P925TS-O Output Cards and P925TS-R Relay cards each pair of input and output cards needs to be set to the same address.

Note:- The P925TS-R Repeat Relay cards do not require the address to be set

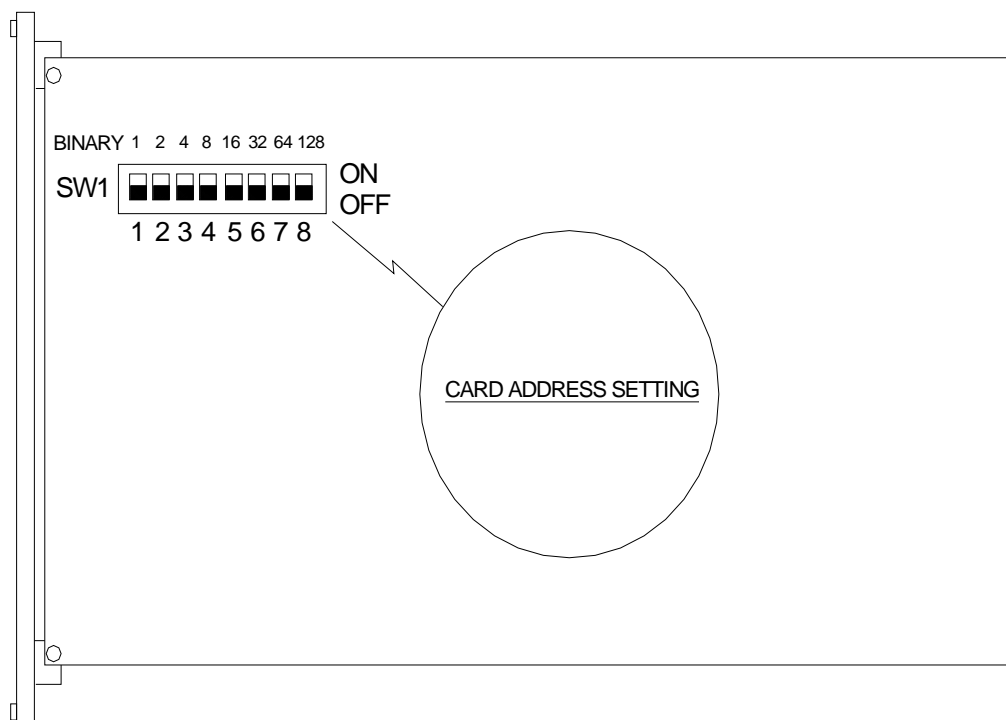

Please note

A maximum of 250 unique addresses can be set as required

Card Address Switch Location

P925TS-I Input / P925TS-O or P925TS-R Output Card Typical Addresses Settings

ADDRESS		DIL SWITCH SW1-							
NO	BINARY	-1	-2	-3	-4	-5	-6	-7	-8
0	00000000	OFF	OFF	OFF	OFF	OFF	OFF	OFF	OFF
1	00000001	ON	OFF	OFF	OFF	OFF	OFF	OFF	OFF
2	00000010	OFF	ON	OFF	OFF	OFF	OFF	OFF	OFF
3	00000011	ON	ON	OFF	OFF	OFF	OFF	OFF	OFF
4	00000100	OFF	OFF	ON	OFF	OFF	OFF	OFF	OFF
5	00000101	ON	OFF	OFF	OFF	OFF	OFF	OFF	OFF
6	00000110	OFF	ON	ON	OFF	OFF	OFF	OFF	OFF
7	00000111	ON	ON	ON	OFF	OFF	OFF	OFF	OFF
8	00001000	OFF	OFF	OFF	ON	OFF	OFF	OFF	OFF
9	00001001	ON	OFF	OFF	ON	OFF	OFF	OFF	OFF
10	00001010	OFF	ON	OFF	ON	OFF	OFF	OFF	OFF
11	00001011	ON	ON	OFF	ON	OFF	OFF	OFF	OFF
12	00001100	OFF	OFF	ON	ON	OFF	OFF	OFF	OFF
13	00001101	ON	OFF	ON	ON	OFF	OFF	OFF	OFF
14	00001110	OFF	ON	ON	ON	OFF	OFF	OFF	OFF
15	00001111	ON	ON	ON	ON	OFF	OFF	OFF	OFF
16	00010000	OFF	OFF	OFF	OFF	ON	OFF	OFF	OFF
17	00010001	ON	OFF	OFF	OFF	ON	OFF	OFF	OFF
18	00010010	OFF	ON	OFF	OFF	ON	OFF	OFF	OFF
19	00010011	OFF	ON	OFF	OFF	ON	OFF	OFF	OFF
20	00010100	OFF	OFF	ON	OFF	ON	OFF	OFF	OFF
21	00010101	ON	OFF	ON	OFF	ON	OFF	OFF	OFF
22	00010110	OFF	ON	ON	OFF	ON	OFF	OFF	OFF
23	00010111	ON	ON	ON	OFF	ON	OFF	OFF	OFF
24	00011000	OFF	OFF	OFF	ON	ON	OFF	OFF	OFF
25	00011001	ON	OFF	OFF	ON	ON	OFF	OFF	OFF
26	00011010	OFF	ON	OFF	ON	ON	OFF	OFF	OFF
27	00011011	ON	ON	OFF	ON	ON	OFF	OFF	OFF
28	00011100	OFF	OFF	ON	ON	ON	OFF	OFF	OFF
29	00011101	ON	OFF	ON	ON	ON	OFF	OFF	OFF
30	00011110	OFF	ON	ON	ON	ON	OFF	OFF	OFF
31	00011111	ON	ON	ON	ON	ON	OFF	OFF	OFF
32	00100000	OFF	OFF	OFF	OFF	OFF	ON	OFF	OFF
33	00100001	ON	OFF	OFF	OFF	OFF	ON	OFF	OFF
34	00100010	OFF	ON	OFF	OFF	OFF	ON	OFF	OFF
35	00100011	ON	ON	OFF	OFF	OFF	ON	OFF	OFF
36	00100100	OFF	OFF	ON	OFF	OFF	ON	OFF	OFF
37	00100101	ON	OFF	ON	OFF	OFF	ON	OFF	OFF
38	00100110	OFF	ON	ON	OFF	OFF	ON	OFF	OFF
39	00100111	ON	ON	ON	OFF	OFF	ON	OFF	OFF
40	00101000	OFF	OFF	OFF	ON	OFF	ON	OFF	OFF

SECTION 14 – END OF LINE LOAD

Communication End Of Line Resistors

Each P925TS-* Card is equipped with two off 2 way DIL switches labelled SW2 and SW3. When selected to the on position these switches provide the required end of line load resistor to balance the communication line. SW2 is used for the RTK internal communication network and SW3 is used for the external communication network. Please note:- SW2 and SW3 should only be set to the on position on the last card in the system

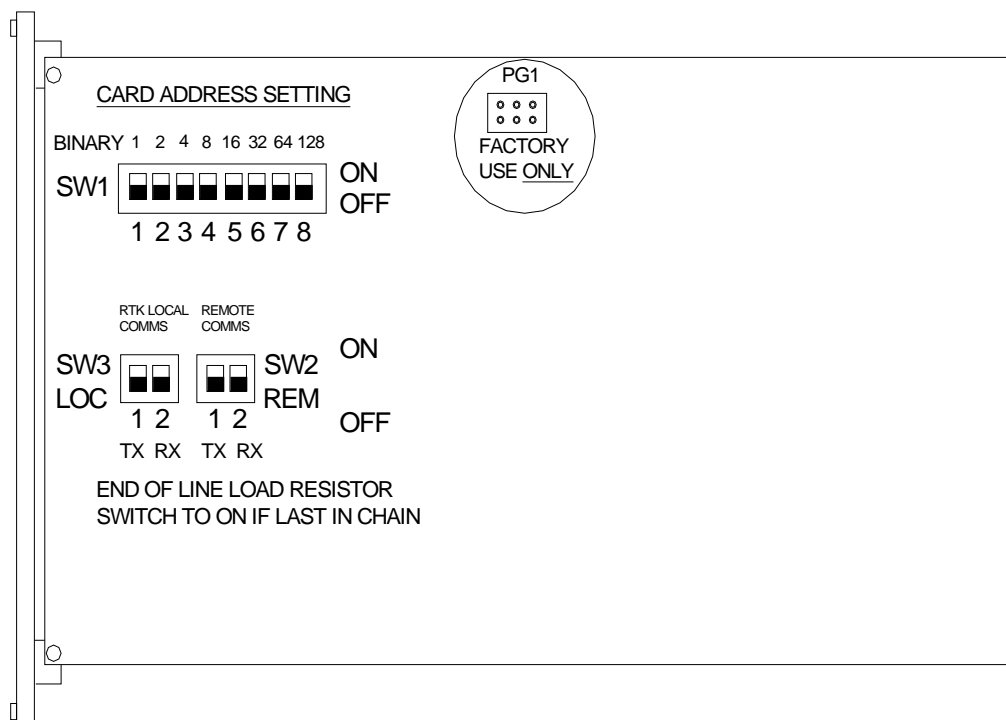

End of Line Resistor Switch Location

SECTION 15 – INTER CARD COMMUNICATIONS

Universal Card Slots

All card slots are universal in application therefore all card types can be inserted from the front of the rack using the associated card guides and once inserted each card automatically connects to the customer terminals located on the rear of the chassis via the motherboard.

Each card slot on the chassis motherboard is equipped with a dedicated 2 way DIL switch located on the inside face of the chassis motherboard.

This switch must be set to the appropriate setting for each application.

If adjacent card slots are equipped with P925TS-I Input Cards the switch should be set to the off position, which will disable the local RTK communications bus between adjacent slots.

However if adjacent card slots are equipped with P925TS-I Input and P925TS-O or R Output Cards the switch must be in the on position.

With switch 1 and 2 in the on position local RTK communication data is passed between the cards to allow the inputs to activate the associated outputs (Lamp/LED or relay).

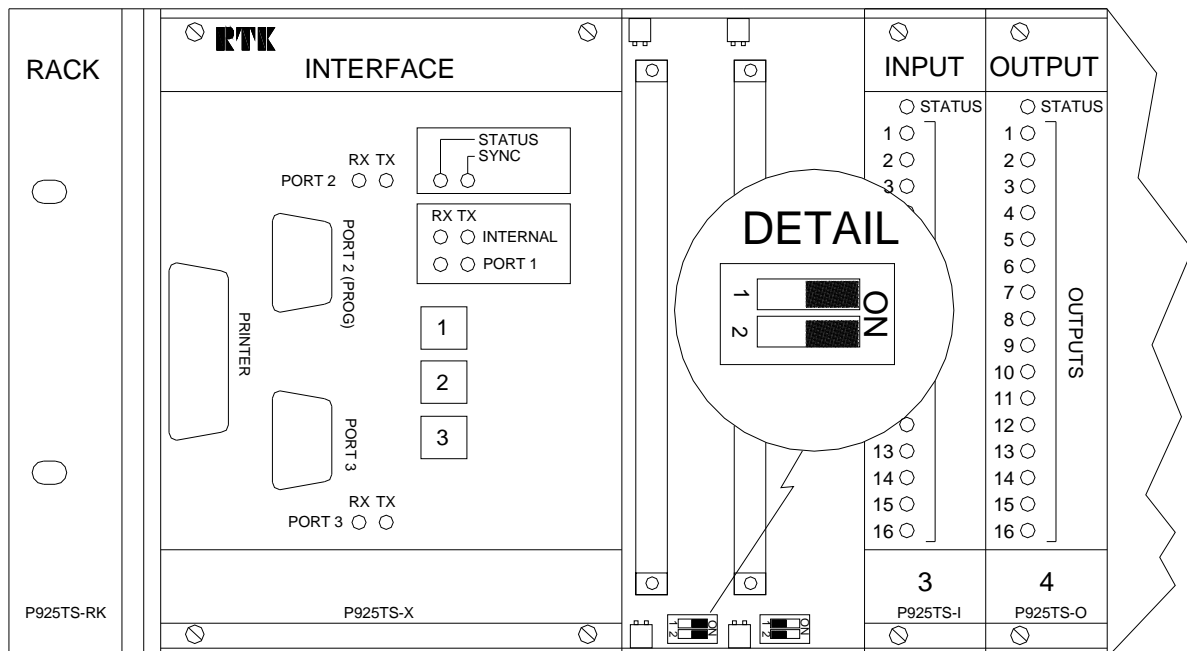

P9000TS Local RTK Communication Switch Location and Setting

When more than one rack is supplied within a 9000TS System a ribbon cable is used to connect all system bus lines between racks using the ribbon OUT of Rack 1 to connect to the ribbon IN of Rack 2. Switches are also provided on the inside face of each of the rack motherboard to allow local communication to be passed between the last card of Rack 1 and the first card of Rack 2 depending on the card type. Example:- If the last slot in the upper rack is a P925TS-I Input Card and the first card in the adjacent rack is a P925TS-O Output Card then the local communication switches must be set to ON in both chassis as shown in the following diagrams.

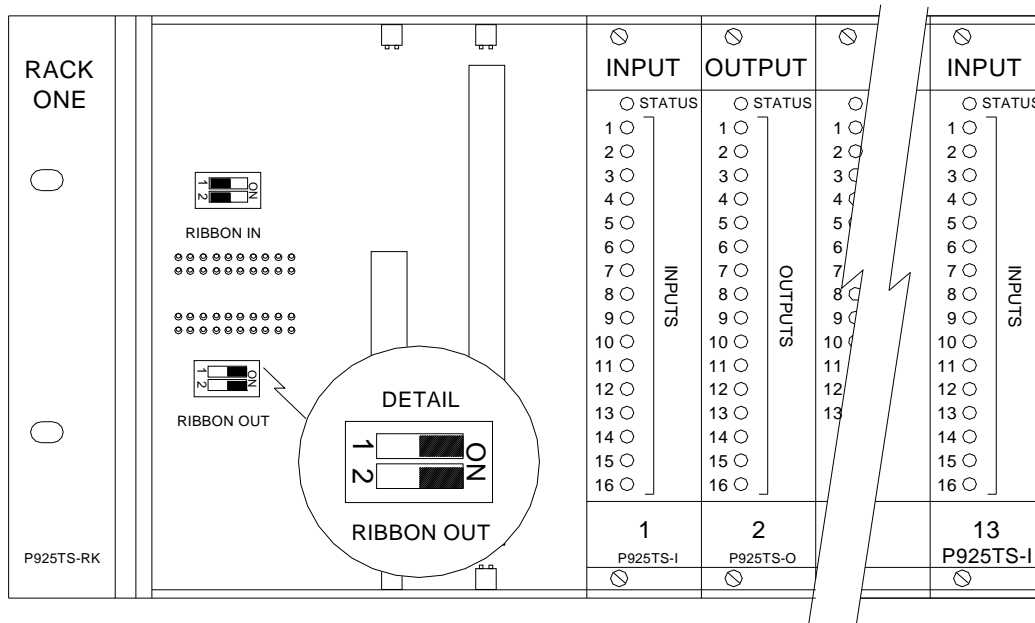

Upper Rack Switch Settings

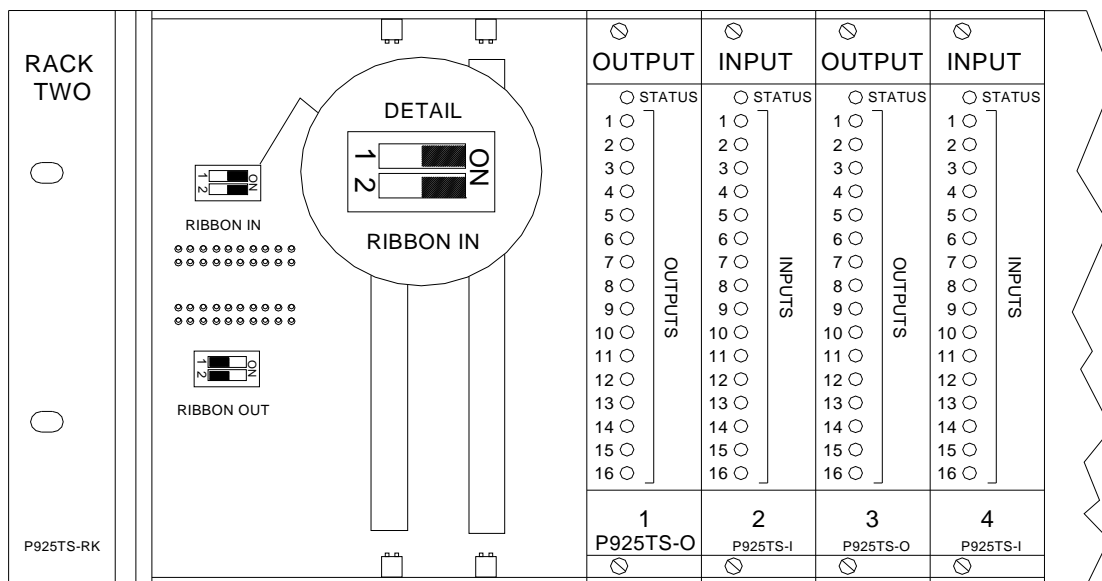

Lower Rack Switch Settings

SECTION 16 – EXAMPLES OF 900TS SYSTEMS

Option 1 – P925TS-I Input Cards Only

Sequence of event function only (Max. 1984 channels per interface card)

Typical 900TS components for a 208 channel SOE only system mounted in a single rack

- 1 - P925TS-RK Rack Chassis
- 1 - P925TS-X Interface Card
- 13 - P925TS-I Input Cards (13 x 16 = 208 channels)

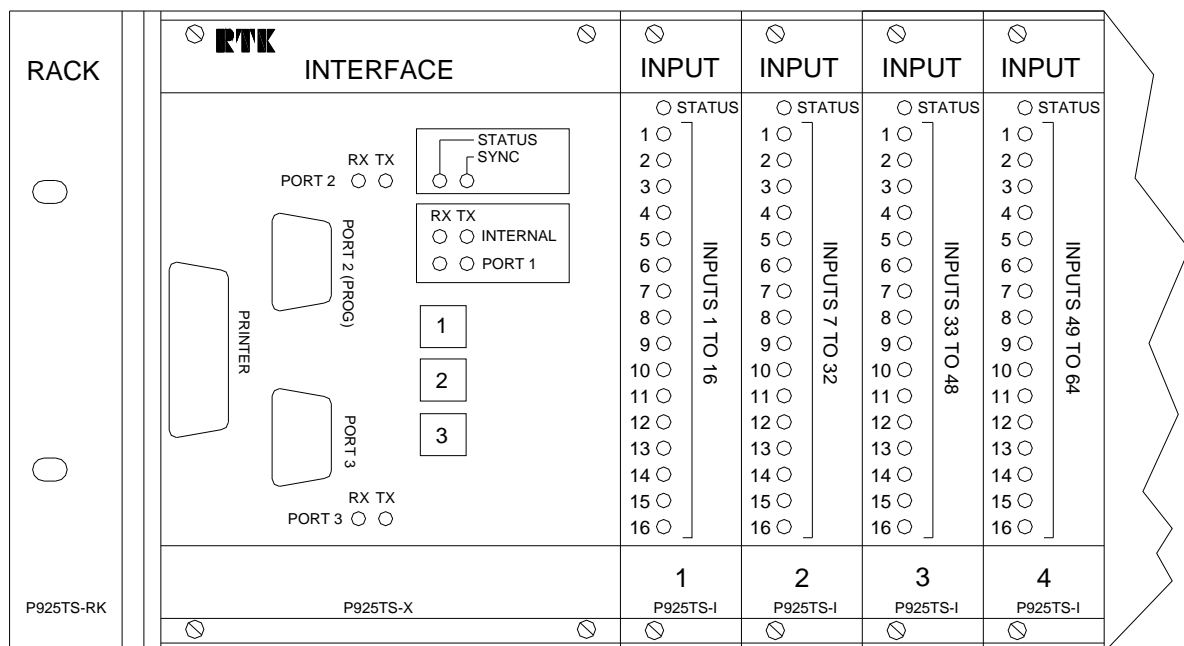

P900TS SOE Only Card Layout

Please note:- The parts indicated above are an example of a typical system. Larger systems can be constructed using multiple racks and additional interface cards if the maximum capacity of a single P925TS-X interface card is exceeded. It is also possible to use a combination of card types to suit specific applications

Option 2 – P925TS-I Input and P925TS-O Output Cards

Sequence of event plus alarm annunciation (Max. 1984 channels per interface card)
 Typical 9000TS components for a 96-channel SOE plus annunciation system mounted in a single rack.

- 1 - P925TS-RK Rack Chassis
- 1 - P925TS-X Interface Card
- 7 - P925TS-I Input Cards (6 x 16 = 96 channels plus 3 pushbutton inputs)
- 6 - P925TS-O Output Cards (6 x 16 = 96 channels)

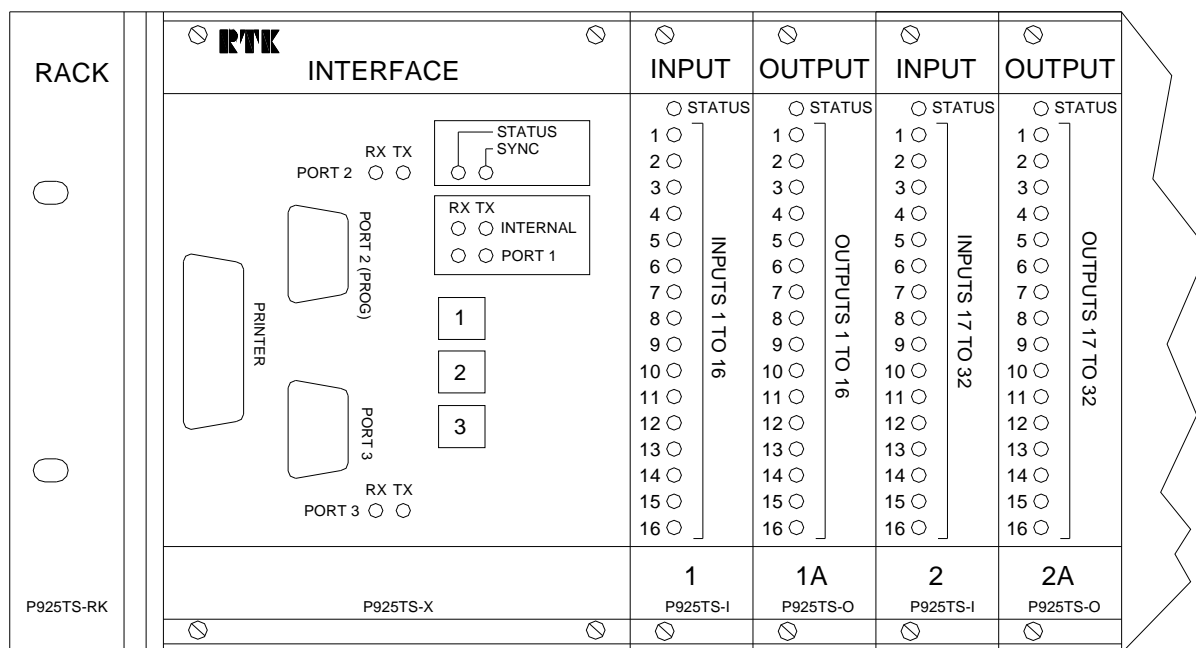

9000TS SOE and Annunciator Card Layout

Please note:- The parts indicated above are an example of a typical system. Larger systems can be constructed using multiple racks and additional interface cards if the maximum capacity of a single P925TS-X interface card is exceeded. It is also possible to use a combination card types to suit specific applications.

Option 3 – P925TS-I Input, P925TS-O Output and P925TS-R Relay Cards

Sequence of event plus annunciation plus repeat relays (Max. 1984 channels per interface card)

Typical 9000TS components for a 48 channel SOE plus annunciation plus repeat relay per channel system mounted in a single rack.

- 1 - P925TS-RK Rack Chassis
- 1 - P925TS-X Interface Card
- 4 - P925TS-I Input Cards (3 x 16 = 48 channels plus 3 pushbutton inputs)
- 3 – P925TS-O Output Cards (3 x 16 = 48 channels)
- 3 – P925TS-R Relay Cards (3 x 16 = 48 relays)

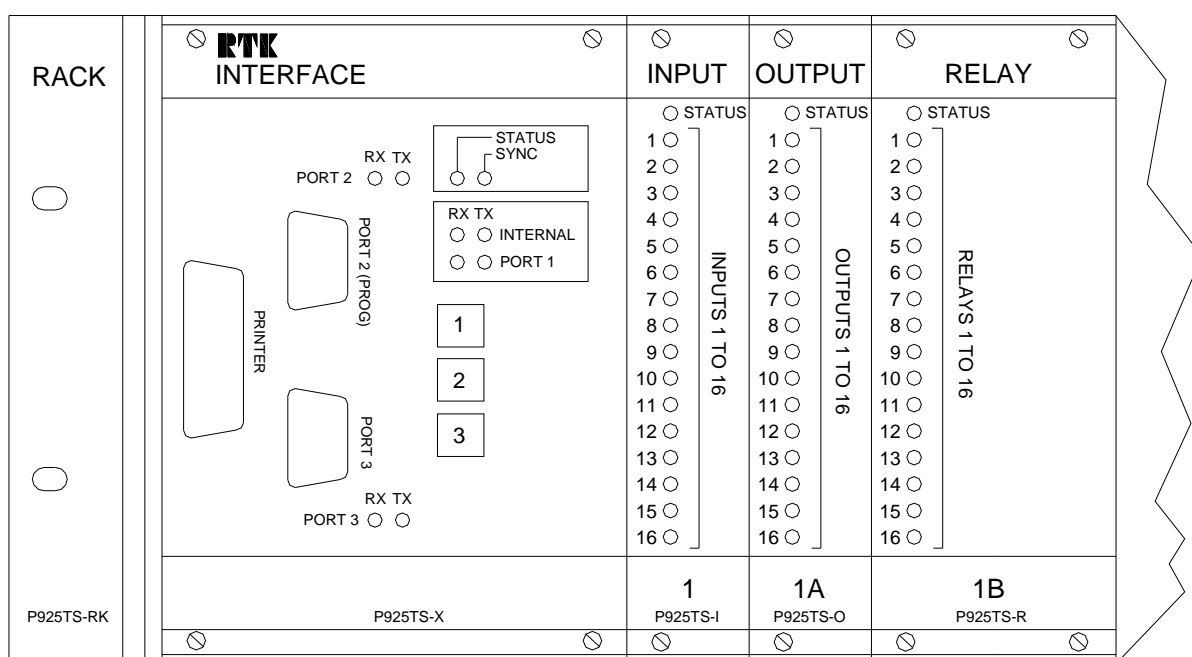

9000TS SOE Annunciator and Repeat Relay Layout Card

Please note:- The parts indicated above are an example of a typical system. Larger systems can be constructed using multiple racks and additional interface cards if the maximum capacity of a single P925TS-X Interface Card is exceeded. It is also possible to use a combination of card types to suit specific applications.

Typical Card location and Address Settings within the P925TS-RK Rack

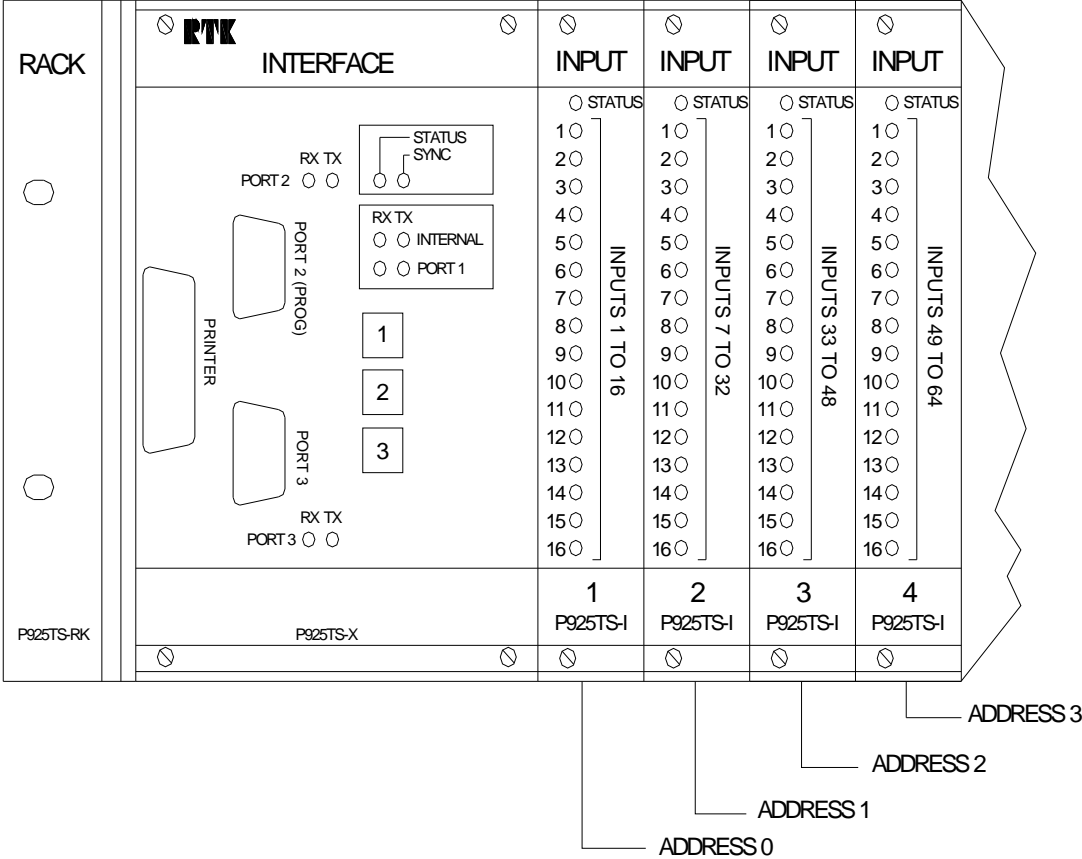

Typical card location and Address Setting for 9000TS Systems equipped with

- P925TS-I Input Cards ONLY

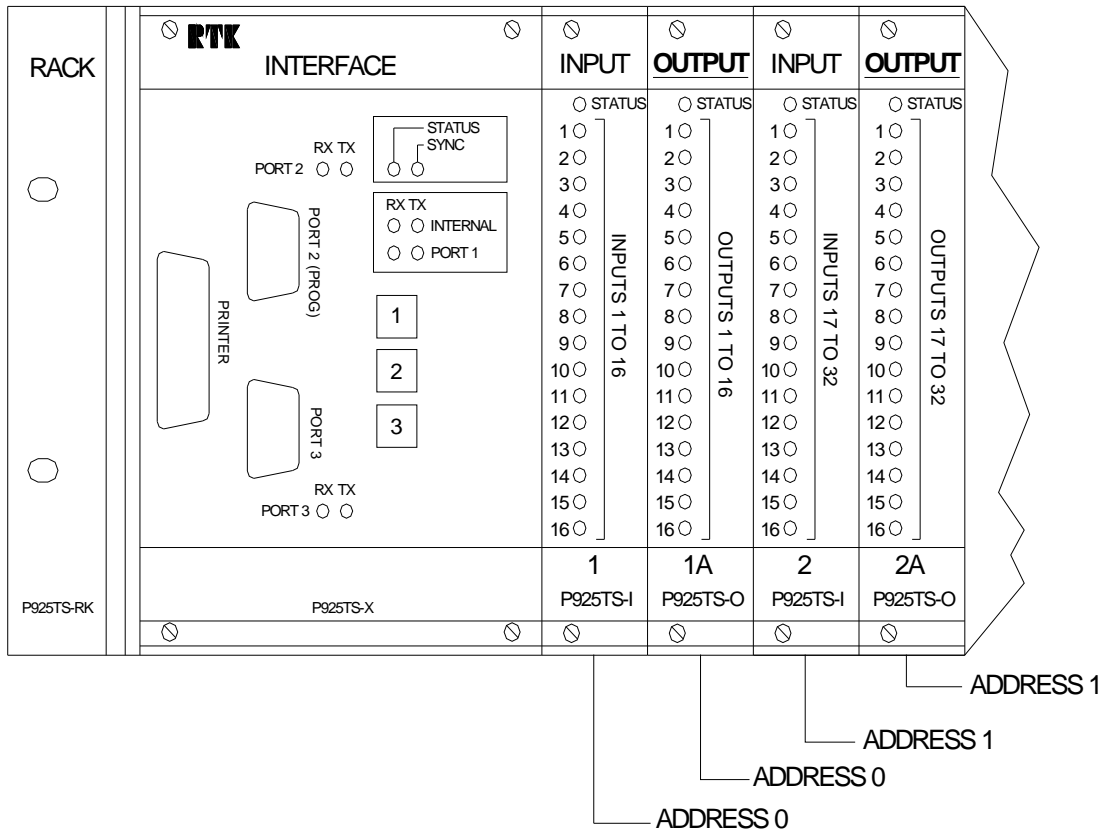

Typical card location and Address Setting for 9000TS Systems equipped with

- P925TS-I Input and
- P925TS-O Output Cards.

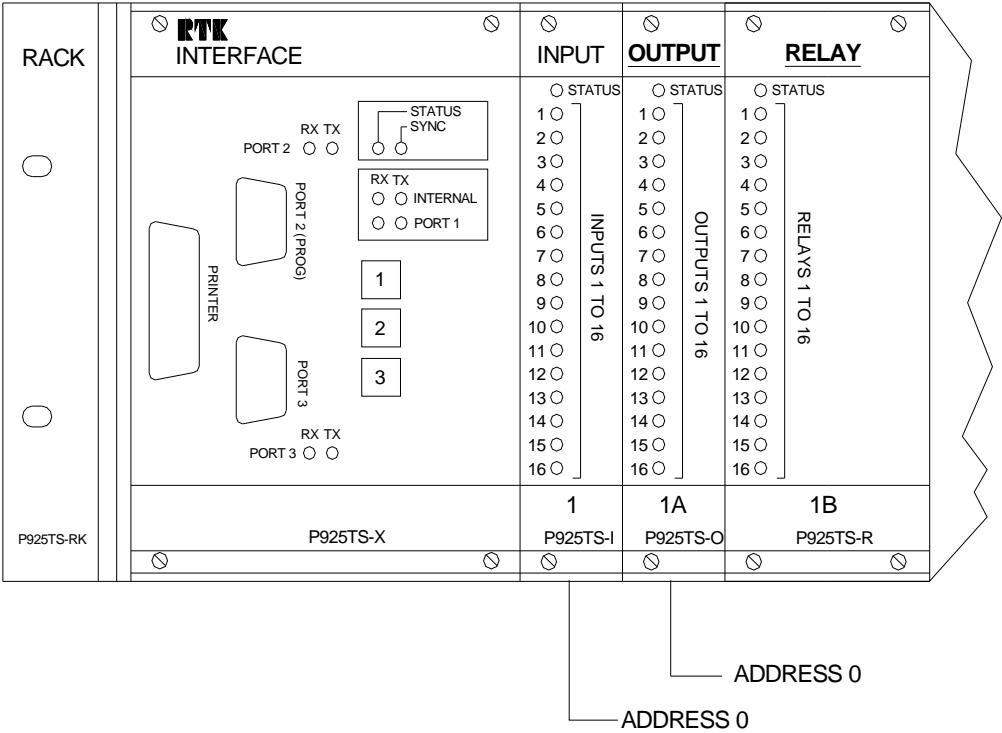

Typical card location and Address Setting for 9000TS Systems equipped with

- P925TS-I Input,
- P925TS-O Output and
- P925TS-R Relay Cards.

SECTION 17 – 9000TS EVENT TYPE KEY

The following lists can be used to identify the event type ET**

P925TS-I Input Card Event Type Key

EVENT TYPE	DESCRIPTION
0	Alarm returning to normal
1	Alarm activation
2	Alarm shelved
3	Alarm manually disabled in software
4	Alarm unshelved
5	Alarm manually enabled in software
6	Configuration change
7	Group inhibited
8	Group uninhibited
9	Lamp test PB activated
10	Lamp test PB return to normal
11	Acknowledge PB activated
12	Acknowledge PB return to normal
13	Reset PB activated
14	Reset PB return to normal
15	Silence PB activated
16	Silence PB return to normal
17	System test PB activated
18	System test PB return to normal
19	First up / Ack PB activated
20	First up / Ack PB return to normal
21	Lamp test / Ack PB activated
22	Lamp test / Ack PB return to normal
23	Sleep mode PB activated
24	Sleep mode PB return to normal
25	Inhibit PB Group 1 activated
26	Inhibit PB Group 1 return to normal
27	Inhibit PB Group 2 activated
28	Inhibit PB Group 2 return to normal
29	Inhibit PB Group 3 activated
30	Inhibit PB Group 3 return to normal
31	Inhibit PB Group 4 activated
32	Inhibit PB Group 4 return to normal
33	Inhibit PB Group 5 activated
34	Inhibit PB Group 5 return to normal
35	Inhibit PB Group 6 activated
36	Inhibit PB Group 6 return to normal
37	Inhibit PB Group 7 activated
38	Inhibit PB Group 7 return to normal

39	Inhibit PB Group 8 activated
40	Inhibit PB Group 8 return to normal
41	Input Fault SC activated – None standard
42	Input Fault SC normal – None standard
43	Input Fault OC activated – None standard
44	Input Fault OC normal – None standard
45	Not used
46	Write input normal
47	Write input abnormal
48	Fram Fault
49	Local relay card OK
50	Local relay card fault
51	Write Disable activated
52	Write Disable normal

P925TS-0 Output Card Event Type Key

EVENT TYPE	DESCRIPTION
64	Alarm event return to normal
65	Subsequent alarm event activated
66	First-up alarm event activated
67	Subsequent alarm event acknowledged
68	First-up alarm event acknowledged
69	Alarm event ringback
70	Configuration change

P925TS-R Relay Card Event Type Key

EVENT TYPE	DESCRIPTION
125	Relay event return to normal
126	Relay event activated
127	Configuration change

9000TS System Internal Event Type Key

EVENT TYPE	DESCRIPTION
128	Printer OK
129	Printer offline
130	Printer busy
131	Printer disconnected
132	Printer no paper
133	Printer unknown state

134	Printer log OK
135	Printer log full
136	Modbus log OK
137	Modbus log full
138	Raw log OK
139	Raw log full
140	Sync OK
141	Sync fail
142	Power OK
143	Power fail
144	Input card found
145	Input card missing
146	Output card found
147	Output card missing
148	Relay card found
149	Relay card missing
150	Watchdog OK
151	Watchdog Fail
152	Contact request OK
153	Contact request Fail
154	Alarm request OK
155	Alarm request Fail
156	Relay request OK
157	Relay request Fail
158	Internal request OK
159	Internal request Fail
160	Disabled request OK
161	Disabled request Fail
162	Gps Lock OK
163	Gps Lock Fail
164	DOM Port 3 serial com OK
165	DOM Port 3 serial com Fail
166	DOM Port 2 serial com OK
167	DOM Port 2 serial com Fail
168	DOM Port 1 serial com OK
169	DOM Port 1 serial com Fail
170	DOM Dualred link OK
171	DOM Dualred link Fail
172	SUB Port 3 serial com OK
173	SUB Port 3 serial com Fail
174	SUB Port 2 serial com OK
175	SUB Port 2 serial com Fail
176	SUB Port 1 serial com OK
177	SUB Port 1 serial com Fail
178	SUB Port 0 serial com OK

179	SUB Port 0 serial com Fail
180	DOM Port 0 serial com OK
181	DOM Port 0 serial com Fail
182	DOM control OK
183	DOM control Fail
184	SUB control OK
185	SUB control Fail
186	SUB DOM Compare Config OK
187	SUB DOM Compare Config Fail
188	DOM SUB Compare Config OK
189	DOM SUB Compare Config Fail
190	SUB Dualred link OK
191	SUB Dualred link Fail

SECTION 18 – PORT 1 SERIAL COMMUNICATIONS

Port 1 Protocol Formats.

PROTOCOL	TYPE	BAUD RATE	START BIT	PARITY BIT	STOP BIT
RTK AMS	RS485	38400	1	EVEN	1
Modbus RTU	RS485	38400	1	EVEN	1
Modbus RTU	RS485	9600	1	NONE	1
Modbus RTU	RS485	9600	1	EVEN	1

AMS Time Stamped Event Protocol

Refer to RTK Instruments for technical assistance

Modbus RTU Protocol

RTU tables. Each character represents 8 bit binary data in hexadecimal format.

Y represents a character with more than one possible value.

TIME represents elapsed time of 3 ½ characters min.

Read Request – Master

START	SYSTEM ADDR	FUNC	START ADDR HI	START ADDR LO	NO. OF INPUTS HI	NO. OF INPUTS LO	LRC ERROR CHECK	STOP
TIME	Y	0x01	Y	Y	Y	Y	YY	TIME

System address

Range is 0x00 (0) to 0xFE (254). Default is 0x00.

Start address HI/LO word

Identifies first data bit to be read. The data type returned for this address depends on a number of factors. Standard systems supplied before August 2011 can only return contact data in the range 0 to 1984:-

Address of first bit = Start address.

Address 0 will contain contact data for inputs 1.

Address 1 will contain contact data for inputs 2.

Address 254 will contain contact data for inputs 255.

Address 255 will contain contact data for inputs 256.

Etc.

Bespoked systems supplied before August 2011 may have additional data types available, please contact RTK for specific information / manual.

After August 2011 all systems have the data types, contact offset and port offset functionality defined below:-

There are two data groups containing data types these are listed below together with their default address range. Contact and port offsets are assumed to be 0:-

- Status Group – Data types
 - **Contact**, Address range 0 – 1984 max.
 - **Alarm**, Address range 2000 – 3984 max.
 - **Relay**, Address range 4000 – 5984 max.
 - **Disable**, Address range 6000 – 7984 max.
 - **Inhibit**, Address range 8000 – 9984 max.
 - **Shelved**, Address range 10000 – 11984 max.
 - **Internal**, Address range 12000 – 13984 max.
 - **Channel Fault**, Address range 14000 – 15984 max.
- Port Group – Data types
 - **Coil**, Address range 16000 – 17984 max.

The data type returned depends on the combination of Start address, Contact Offset, Port Offset and number of inputs.

Note: If status and coil first data bits overlap “coincide” the data type returned will always be Status.

Status data type - Address of first data bit = Start address - Contact Offset.

Examples below with Contact offset = 0:-

- Default – Start address 0 - Contact status data for input 1.
- Default – Start address 2000 - Alarm status data for input 1.
- Default – Start address 4000 - Relay Contact status data for input 1.
- Default – Start address 6000 - Disable status data for input 1.
- Default – Start address 8000 - Inhibit Contact status data for input 1.
- Default – Start address 10000 - Shelved status data for input 1.
- Default – Start address 12000 - Internal status data for input 1.
- Default – Start address 14000 – Channel Fault status data for input 1.

Examples below with Contact offset = 40000:-

- Default – Start address 40000 - Contact status data for input 1.
- Default – Start address 42000 - Alarm status data for input 1.
- Default – Start address 44000 - Relay Contact status data for input 1.
- Default – Start address 46000 - Disable status data for input 1.
- Default – Start address 48000 - Inhibit Contact status data for input 1.
- Default – Start address 50000 - Shelved status data for input 1.
- Default – Start address 52000 - Internal status data for input 1.
- Default – Start address 54000 – Channel Fault status data for input 1.

Port data type - Address of first data bit = Start address – Port Offset.

Example below with Port offset = 0:-

Default – Start address 16000 - Coil data for input 1.

Example below with contact offset = 40000:-

Default – Start address 56000 - Coil data for input 1.

Note: If status and coil first data bits overlap “coincide” the data type returned will always be Status.

No of inputs HI/LO word

Number of data bits to return. Maximum allowable number of data bits “channels” to read with single message is 1984.

Status data type – Address of Last data bit =
(No of inputs – 1) + (Start address - Contact Offset).

Port data type - Address of Last data bit =
(No of inputs – 1) + (Start address – Port Offset).

Note: If status and coil first data bits overlap “coincide” the data type returned will always be Status.

Read Response – 9000TS Slave

START	SYSTEM ADDR	FUNC	BYTE COUNT N	DATA BYTES	LRC ERROR CHECK	STOP
TIME	Y	0X01	Y	Y * N	YY	TIME

System address

Range is 0x00 (0) to 0xFE (254). Default is 0x00.

Byte count

Number of data Bytes returned. One data byte is returned for every 8 data bits requested with a minimum of one data byte assuming at least one data bit was requested.

Data Byte 1, Bit 0 = First data bit requested.

Data Byte 1, Bit 7 = 8TH data bit requested.

Data Byte 2, Bit 0 = 9TH data bit requested.

Data Byte 2, Bit 7 = 16TH data bit requested.

Etc.

Write Single Request/Response – Master and 9000TS Slave

Master write request and 9000TS slave write response are the same.

START	SYSTEM ADDR	FUNC	DATA ADDR HI	DATA ADDR LO	DATA HI	DATA LO	LRC ERROR CHECK	STOP
TIME	Y	0x05	Y	Y	Y	Y	YY	TIME

System address

Range is 0x00 (0) to 0xFE (254). Default is 0x00.

Data address word HI/LO word

Identifies the address of the data bit to be written. Only port coil data type can be written:-

Port Coil Address = Data address + Port Offset.

Default first coil address in system = 0.

Data HI/LO word

Set Coil abnormal: Data HI = 0xFF, Data LO = 0x00.

Set Coil normal: Data HI = 0x00, Data LO = 0x00.

Write Multiple Request – Master

START	SYSTEM ADDR	FUNC	START ADDR HI	START ADDR LO	NUM COILS HI	NUM COILS LO	BYTE COUNT N	DATA BYTES	LRC ERROR CHECK	STOP
TIME	Y	0x0F	Y	Y	Y	Y	Y	Y * N	YY	TIME

System address

Range is 0x00 (0) to 0xFE (254). Default is 0x00.

Start address word HI/LO word

Identifies the address of the first data bit to be written. Only port coil data type can be written:-

First Port Coil Address = Start address + Port Offset.

Default first coil address in system = 0

Number coils HI/LO word

Number of coils to be written. Max number possible 1984.

Byte Count

Number of data Bytes sent. One data byte is sent for every 8 data bits “coils” written with a minimum of one data byte assuming at least one data bit “coil” is written.

Data Bytes

Each bit in a data byte represents a coil.

Set Input abnormal: Data bit = HI.

Set Input normal: Data bit = LO.

Write Multiple Response – Slave

START	SYSTEM ADDR	FUNC	START ADDR HI	START ADDR LO	NUM INPUTS HI	NUM INPUTS LO	LRC ERROR CHECK	STOP
TIME	Y	0x0F	Y	Y	Y	Y	YY	TIME

System address

Range is 0x00 (0) to 0xFE (254). Default is 0x00.

Start address HI/LO word

Same as the original request.

Number inputs HI/LO word

Same as the original request.

Exception Response – 9000TS Slave

9000TS slave response to invalid requests.

START	FUNCTION	SYSTEM ADDR	EXCEPTION CODE	LRC ERROR CHECK	STOP
TIME	Y	Y	Y	YY	TIME

System address

Range is 0x00 (0) to 0xFE (254). Default is 0x00.

Function

Invalid read request function 0x01 = 0x81.

Invalid write request function 0x05 = 0x85.

Invalid write request function 0x0F = 0x8F.

Exception Codes

Illegal data address = 0x02.

Illegal data value = 0x03.

Busy = 0x06.

SECTION 19 – PORT 2 SERIAL COMMUNICATION

Port 2 Protocol Formats.

PROTOCOL	TYPE	BAUD RATE	START BIT	PARITY BIT	STOP BIT
PROG	RS232	38400	1	EVEN	1
MODBUS RTU	RS232	38400	1	EVEN	1
MODBUS RTU	RS232	9600	1	NONE	1
GPS WF1	RS232	19200	1	EVEN	1

PROG

Port is available for programming function only.

MODBUS RTU

Note: If port is set for a protocol other than programming i.e. dual function then button 2 on the front of the interface card should be used to toggle between functions – Refer to configuration manual for more details.

Modbus RTU Protocol

RTU tables. Each character represents 8 bit binary data in hexadecimal format.

Y represents a character with more than one possible value.

TIME represents elapsed time of 3 ½ characters min.

Read Request – Master

START	SYSTEM ADDR	FUNC	START ADDR HI	START ADDR LO	NO. OF INPUTS HI	NO. OF INPUTS LO	LRC ERROR CHECK	STOP
TIME	Y	0x01	Y	Y	Y	Y	YY	TIME

System address

Range is 0x00 (0) to 0xFE (254). Default is 0x00.

Start address HI/LO word

Identifies first data bit to be read. The data type returned for this address depends on a number of factors. Standard systems supplied before August 2011 can only return contact data in the range 0 to 1984:-

Address of first bit = Start address.

Address 0 will contain contact data for inputs 1.

Address 1 will contain contact data for inputs 2.

Address 254 will contain contact data for inputs 255.
 Address 255 will contain contact data for inputs 256.
 Etc.

Bespoked systems supplied before August 2011 may have additional data types available, please contact RTK for specific information / manual.
 After August 2011 all systems have the data types, contact offset and port offset functionality defined below:-

There are two data groups containing data types these are listed below together with their default address range. Contact and port offsets are assumed to be 0:-

- Status Group – Data types
 - **Contact**, Address range 0 – 1984 max.
 - **Alarm**, Address range 2000 – 3984 max.
 - **Relay**, Address range 4000 – 5984 max.
 - **Disable**, Address range 6000 – 7984 max.
 - **Inhibit**, Address range 8000 – 9984 max.
 - **Shelved**, Address range 10000 – 11984 max.
 - **Internal**, Address range 12000 – 13984 max.
 - **Channel Fault**, Address range 14000 – 15984 max.
- Port Group – Data types
 - **Coil**, Address range 16000 – 17984 max.

The data type returned depends on the combination of Start address, Contact Offset, Port Offset and number of inputs.

Note: If status and coil first data bits overlap “coincide” the data type returned will always be Status.

Status data type - Address of first data bit = Start address - Contact Offset.

Examples below with Contact offset = 0:-

Default – Start address 0 - Contact status data for input 1.
 Default – Start address 2000 - Alarm status data for input 1.
 Default – Start address 4000 - Relay Contact status data for input 1.
 Default – Start address 6000 - Disable status data for input 1.
 Default – Start address 8000 - Inhibit Contact status data for input 1.
 Default – Start address 10000 - Shelved status data for input 1.
 Default – Start address 12000 - Internal status data for input 1.
 Default – Start address 14000 – Channel Fault status data for input 1.

Examples below with Contact offset = 40000:-

Default – Start address 40000 - Contact status data for input 1.
 Default – Start address 42000 - Alarm status data for input 1.
 Default – Start address 44000 - Relay Contact status data for input 1.
 Default – Start address 46000 - Disable status data for input 1.
 Default – Start address 48000 - Inhibit Contact status data for input 1.

Default – Start address 50000 - Shelved status data for input 1.
Default – Start address 52000 - Internal status data for input 1.
Default – Start address 54000 – Channel Fault status data for input 1.

Port data type - Address of first data bit = Start address – Port Offset.

Example below with Port offset = 0:-

Default – Start address 16000 - Coil data for input 1.

Example below with contact offset = 40000:-

Default – Start address 56000 - Coil data for input 1.

Note: If status and coil first data bits overlap “coincide” the data type returned will always be Status.

No of inputs HI/LO word

Number of data bits to return. Maximum allowable number of data bits “channels” to read with single message is 1984.

Status data type – Address of Last data bit =
(No of inputs – 1) + (Start address - Contact Offset).

Port data type - Address of Last data bit =
(No of inputs – 1) + (Start address – Port Offset).

Note: If status and coil first data bits overlap “coincide” the data type returned will always be Status.

Read Response – 9000TS Slave

START	SYSTEM ADDR	FUNC	BYTE COUNT N	DATA BYTES	LRC ERROR CHECK	STOP
TIME	Y	0X01	Y	Y * N	YY	TIME

System address

Range is 0x00 (0) to 0xFE (254). Default is 0x00.

Byte count

Number of data Bytes returned. One data byte is returned for every 8 data bits requested with a minimum of one data byte assuming at least one data bit was requested.

Data Byte 1, Bit 0 = First data bit requested.

Data Byte 1, Bit 7 = 8TH data bit requested.

Data Byte 2, Bit 0 = 9TH data bit requested.

Data Byte 2, Bit 7 = 16TH data bit requested.

Etc.

Write Single Request/Response – Master and 9000TS Slave

Master write request and 9000TS slave write response are the same.

START	SYSTEM ADDR	FUNC	DATA ADDR HI	DATA ADDR LO	DATA HI	DATA LO	LRC ERROR CHECK	STOP
TIME	Y	0x05	Y	Y	Y	Y	YY	TIME

System address

Range is 0x00 (0) to 0xFE (254). Default is 0x00.

Data address word HI/LO word

Identifies the address of the data bit to be written. Only port coil data type can be written:-

Port Coil Address = Data address + Port Offset.

Default first coil address in system = 0.

Data HI/LO word

Set Coil abnormal: Data HI = 0xFF, Data LO = 0x00.

Set Coil normal: Data HI = 0x00, Data LO = 0x00.

Write Multiple Request – Master

START	SYSTEM ADDR	FUNC	START ADDR HI	START ADDR LO	NUM COILS HI	NUM COILS LO	BYTE COUNT N	DATA BYTES	LRC ERROR CHECK	STOP
TIME	Y	0x0F	Y	Y	Y	Y	Y	Y * N	YY	TIME

System address

Range is 0x00 (0) to 0xFE (254). Default is 0x00.

Start address word HI/LO word

Identifies the address of the first data bit to be written. Only port coil data type can be written:-

First Port Coil Address = Start address + Port Offset.

Default first coil address in system = 0

Number coils HI/LO word

Number of coils to be written. Max number possible 1984.

Byte Count

Number of data Bytes sent. One data byte is sent for every 8 data bits “coils” written with a minimum of one data byte assuming at least one data bit “coil” is written.

Data Bytes

Each bit in a data byte represents a coil.

Set Input abnormal: Data bit = HI.

Set Input normal: Data bit = LO.

Write Multiple Response – Slave

START	SYSTEM ADDR	FUNC	START ADDR HI	START ADDR LO	NUM INPUTS HI	NUM INPUTS LO	LRC ERROR CHECK	STOP
TIME	Y	0x0F	Y	Y	Y	Y	YY	TIME

System address

Range is 0x00 (0) to 0xFE (254). Default is 0x00.

Start address HI/LO word

Same as the original request.

Number inputs HI/LO word

Same as the original request.

Exception Response – 9000TS Slave

9000TS slave response to invalid requests.

START	FUNCTION	SYSTEM ADDR	EXCEPTION CODE	LRC ERROR CHECK	STOP
TIME	Y	Y	Y	YY	TIME

System address

Range is 0x00 (0) to 0xFE (254). Default is 0x00.

Function

Invalid read request function 0x01 = 0x81.

Invalid write request function 0x05 = 0x85.

Invalid write request function 0x0F = 0x8F.

Exception Codes

Illegal data address = 0x02.

Illegal data value = 0x03.

Busy = 0x06.

Wharton Protocol

Refer to manufacturers manual or RTK Instruments for additional information.

Note: If port is set for a protocol other than programming i.e. dual function, then button 2 on the front of the interface card should be used to toggle between functions – Refer to configuration manual or more details.

SECTION 20 – PORT 3 SERIAL COMMUNICATION

Port 3 Protocol Formats.

PROTOCOL	TYPE	BAUD RATE	START BIT	PARITY	STOP BIT
Wharton Format 1 Date & Time Protocol	RS232	19200	1	EVEN	1
HOPF Date & Time Protocol	RS232	19200	1	EVEN	1
FOXBRGH “MODBUS RTU”	RS232	9600	1	EVEN	1
AUG CAT “MODBUS RTU”	RS232	9600	1	NONE	1
AUG G22 “MODBUS RTU”	RS232	9600	1	NONE	1
AUG ALM “MODBUS RTU”	RS232	9600	1	NONE	1
9000TS MASTER “MODBUS RTU”	RS232	9600	1	EVEN	1
9000TS SLAVE “MODBUS RTU”	RS232	9600	1	EVEN	1
GLOBAL MASTER ”MODBUS RTU”	RS232	38400	1	EVEN	1

Wharton Protocol

Refer to manufacturers manual or RTK Instruments for additional information.

HOPF Protocol

Refer to manufacturers manual or RTK Instruments for additional information.

FOXBRGH 9600 E 1 8

This allows the user to connect the 9000TS system to a Foxborough 3rd party device, Protocol is standard Modbus RTU, Contact RTK for additional information.

AUG CAT, G22, ALM

This allows the user to connect the 9000TS system to an August PLC 3rd party device with a bespoke port mapping structure, Protocol is standard Modbus RTU. Contact RTK for additional information.

Modbus RTU Protocol

RTU tables. Each character represents 8 bit binary data in hexadecimal format.

Y represents a character with more than one possible value.

TIME represents elapsed time of 3 ½ characters min.

Read Request – Master

START	SYSTEM ADDR	FUNC	START ADDR HI	START ADDR LO	NO. OF INPUTS HI	NO. OF INPUTS LO	LRC ERROR CHECK	STOP
TIME	Y	0x01	Y	Y	Y	Y	YY	TIME

System address

Range is 0x00 (0) to 0xFE (254). Default is 0x00.

Start address HI/LO word

Identifies first data bit to be read. The data type returned for this address depends on a number of factors. Standard systems supplied before August 2011 can only return contact data in the range 0 to 1984:-

Address of first bit = Start address.

Address 0 will contain contact data for inputs 1.

Address 1 will contain contact data for inputs 2.

Address 254 will contain contact data for inputs 255.

Address 255 will contain contact data for inputs 256.

Etc.

Bespoked systems supplied before August 2011 may have additional data types available, please contact RTK for specific information / manual.

After August 2011 all systems have the data types, contact offset and port offset functionality defined below:-

There are two data groups containing data types these are listed below together with their default address range. Contact and port offsets are assumed to be 0:-

- Status Group – Data types
 - **Contact**, Address range 0 – 1984 max.
 - **Alarm**, Address range 2000 – 3984 max.
 - **Relay**, Address range 4000 – 5984 max.
 - **Disable**, Address range 6000 – 7984 max.
 - **Inhibit**, Address range 8000 – 9984 max.
 - **Shelved**, Address range 10000 – 11984 max.
 - **Internal**, Address range 12000 – 13984 max.
 - **Channel Fault**, Address range 14000 – 15984 max.
- Port Group – Data types
 - **Coil**, Address range 16000 – 17984 max.

The data type returned depends on the combination of Start address, Contact Offset, Port Offset and number of inputs.

Note: If status and coil first data bits overlap “coincide” the data type returned will always be Status.

Status data type - Address of first data bit = Start address - Contact Offset.

Examples below with Contact offset = 0:-

- Default – Start address 0 - Contact status data for input 1.
- Default – Start address 2000 - Alarm status data for input 1.
- Default – Start address 4000 - Relay Contact status data for input 1.
- Default – Start address 6000 - Disable status data for input 1.
- Default – Start address 8000 - Inhibit Contact status data for input 1.
- Default – Start address 10000 - Shelved status data for input 1.
- Default – Start address 12000 - Internal status data for input 1.
- Default – Start address 14000 – Channel Fault status data for input 1.

Examples below with Contact offset = 40000:-

- Default – Start address 40000 - Contact status data for input 1.
- Default – Start address 42000 - Alarm status data for input 1.
- Default – Start address 44000 - Relay Contact status data for input 1.
- Default – Start address 46000 - Disable status data for input 1.
- Default – Start address 48000 - Inhibit Contact status data for input 1.
- Default – Start address 50000 - Shelved status data for input 1.
- Default – Start address 52000 - Internal status data for input 1.
- Default – Start address 54000 – Channel Fault status data for input 1.

Port data type - Address of first data bit = Start address – Port Offset.

Example below with Port offset = 0:-

- Default – Start address 16000 - Coil data for input 1.

Example below with contact offset = 40000:-

- Default – Start address 56000 - Coil data for input 1.

Note: If status and coil first data bits overlap “coincide” the data type returned will always be Status.

No of inputs HI/LO word

Number of data bits to return. Maximum allowable number of data bits “channels” to read with single message is 1984.

Status data type – Address of Last data bit =
(No of inputs – 1) + (Start address - Contact Offset).

Port data type - Address of Last data bit =
(No of inputs – 1) + (Start address – Port Offset).

Note: If status and coil first data bits overlap “coincide” the data type returned will always be Status.

Read Response – 9000TS Slave

START	SYSTEM ADDR	FUNC	BYTE COUNT N	DATA BYTES	LRC ERROR CHECK	STOP
TIME	Y	0X01	Y	Y * N	YY	TIME

System address

Range is 0x00 (0) to 0xFE (254). Default is 0x00.

Byte count

Number of data Bytes returned. One data byte is returned for every 8 data bits requested with a minimum of one data byte assuming at least one data bit was requested.

Data Byte 1, Bit 0 = First data bit requested.

Data Byte 1, Bit 7 = 8TH data bit requested.

Data Byte 2, Bit 0 = 9TH data bit requested.

Data Byte 2, Bit 7 = 16TH data bit requested.

Etc.

Write Single Request/Response – Master and 9000TS Slave

Master write request and 9000TS slave write response are the same.

START	SYSTEM ADDR	FUNC	DATA ADDR HI	DATA ADDR LO	DATA HI	DATA LO	LRC ERROR CHECK	STOP
TIME	Y	0x05	Y	Y	Y	Y	YY	TIME

System address

Range is 0x00 (0) to 0xFE (254). Default is 0x00.

Data address word HI/LO word

Identifies the address of the data bit to be written. Only port coil data type can be written:-

Port Coil Address = Data address + Port Offset.

Default first coil address in system = 0.

Data HI/LO word

Set Coil abnormal: Data HI = 0xFF, Data LO = 0x00.

Set Coil normal: Data HI = 0x00, Data LO = 0x00.

Write Multiple Request – Master

START	SYSTEM ADDR	FUNC	START ADDR HI	START ADDR LO	NUM COILS HI	NUM COILS LO	BYTE COUNT N	DATA BYTES	LRC ERROR CHECK	STOP
TIME	Y	0x0F	Y	Y	Y	Y	Y	Y * N	YY	TIME

System address

Range is 0x00 (0) to 0xFE (254). Default is 0x00.

Start address word HI/LO word

Identifies the address of the first data bit to be written. Only port coil data type can be written:-

First Port Coil Address = Start address + Port Offset.

Default first coil address in system = 0

Number coils HI/LO word

Number of coils to be written. Max number possible 1984.

Byte Count

Number of data Bytes sent. One data byte is sent for every 8 data bits “coils” written with a minimum of one data byte assuming at least one data bit “coil” is written.

Data Bytes

Each bit in a data byte represents a coil.

Set Input abnormal: Data bit = HI.

Set Input normal: Data bit = LO.

Write Multiple Response – Slave

START	SYSTEM ADDR	FUNC	START ADDR HI	START ADDR LO	NUM INPUTS HI	NUM INPUTS LO	LRC ERROR CHECK	STOP
TIME	Y	0x0F	Y	Y	Y	Y	YY	TIME

System address

Range is 0x00 (0) to 0xFE (254). Default is 0x00.

Start address HI/LO word

Same as the original request.

Number inputs HI/LO word

Same as the original request.

Exception Response – 9000TS Slave

9000TS slave response to invalid requests.

START	FUNCTION	SYSTEM ADDR	EXCEPTION CODE	LRC ERROR CHECK	STOP
TIME	Y	Y	Y	YY	TIME

System address

Range is 0x00 (0) to 0xFE (254). Default is 0x00.

Function

Invalid read request function 0x01 = 0x81.

Invalid write request function 0x05 = 0x85.

Invalid write request function 0x0F = 0x8F.

Exception Codes

Illegal data address = 0x02.

Illegal data value = 0x03.

Busy = 0x06.

SECTION 21 – IRIGB – option

The 9000TS system can be linked to an IRIGB network providing accurate time and date information. This option is not provided as default and should be requested when ordering.

Time Code Input Specifications:-

Format types - auto detected

IRIGA (A132) (BNC analogue)

IRIGB (B122), (B123) (BNC analogue)

NASA (BNC analogue)

Amplitude

2 Vpk - pk min, 10Vpk - pk max

Polarity

Detected automatically

Modulation ratio

2:1 min, 3:1 typical, 4:1 max

Input impedance

>10K Ohms

Timing Accuracy

Better than 100ppm

Common Mode Voltage

Differential input, +/-100V max

Connections and hardware settings:-

IRIGB Input

BNC connector located on rear of the first rack.

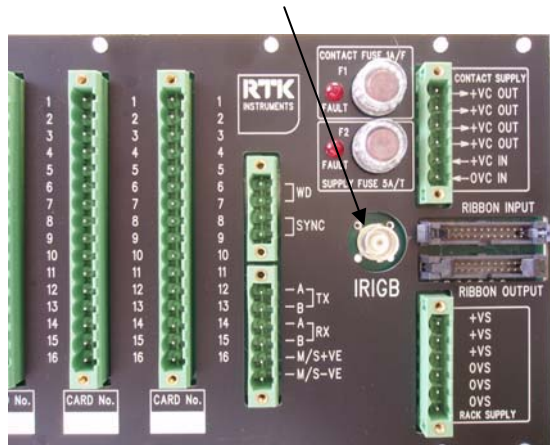

Rack switch setting's

Switches are located within the first rack, at the rear of the interface card slot.

Switch settings for **SINGLE** interface card rack:-

IRIGB SW16 position 1 – OFF

IRIGB SW16 position 2 – OFF

IRIGB SW15 position 1 – ON

IRIGB SW15 position 2 - ON

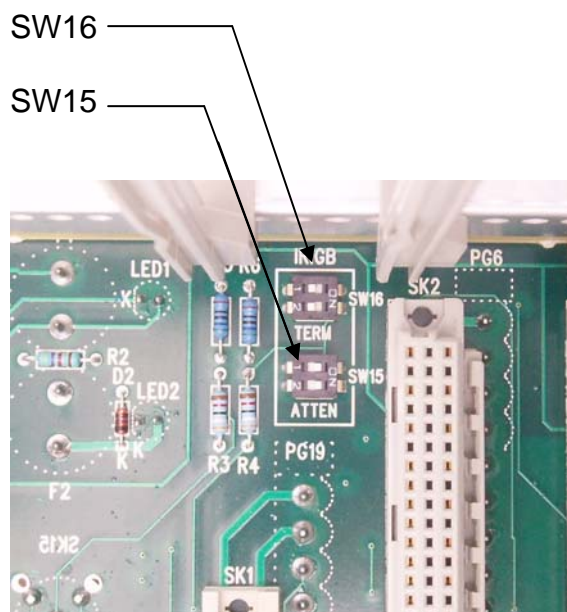

Switch settings for **DUAL** interface card rack:-
IRIGB SW1 position 1 – ON
IRIGB SW1 position 2 – ON
IRIGB SW2 position 1 – OFF
IRIGB SW2 position 2 – OFF

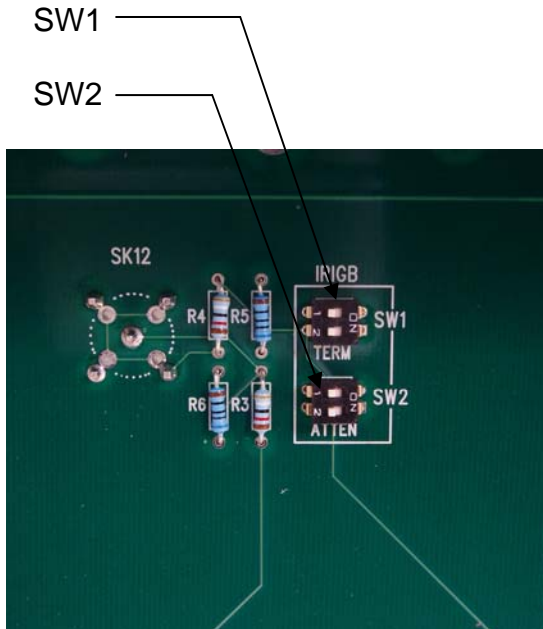

IRIGB Card link settings

There are no customer selectable links on the IRIGB card. Link positions are shown below for information only

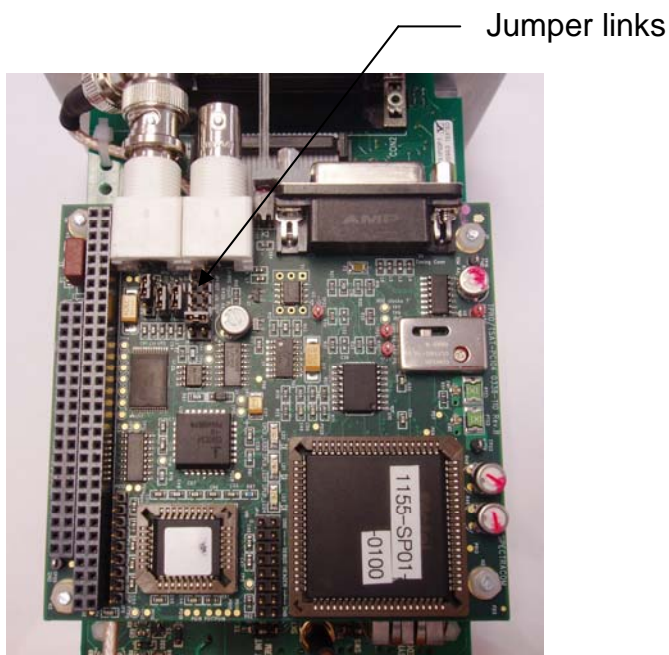

IRIGB Card Status indication:-

The IRIGB card status can be ascertained via an LED (LED5) situated on the front of the IRIGB card. On earlier models the status LED could only be viewed by looking through the top of the rack via the grill, on the latest versions a viewing window on the front of the interface card has been added.

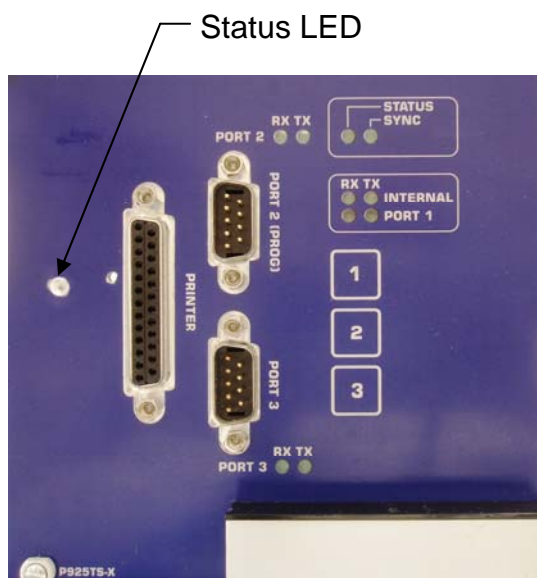
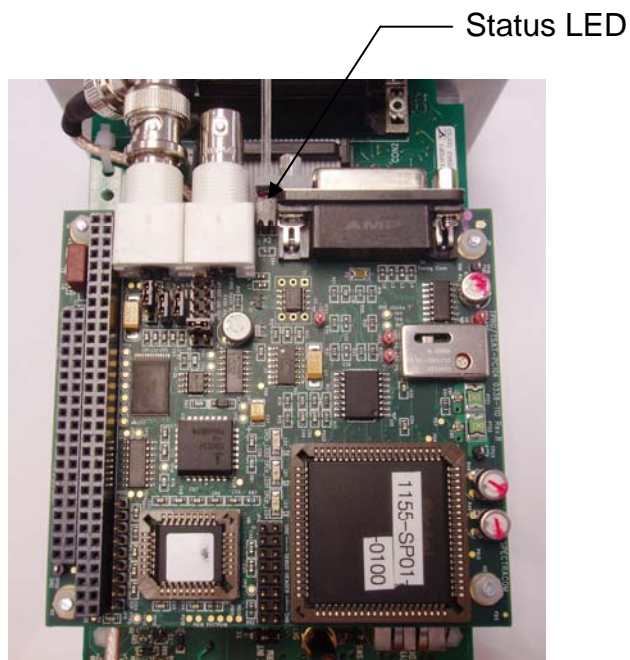

The status LED flashes a status pattern to assist in diagnosing installation errors. The pattern is a sequence of short and long flashes. Trailing short flashes are deleted so the status pattern can repeat more frequently. Table below details these patterns, it includes data relating to GPS communications which is not relevant, only flash positions 2 and 6 should be considered for the purpose of IRIGB diagnostics.

Flash Position	Flash Position Meaning of Short (cleared) Flash	Meaning of Long (set) Flash
1	GPS satellite receiver being used for time reference	Modulated time code input being used for time reference
2	Synchronization to better than 5 μ sec verified with last 5 seconds	Synchronization to better than 5 μ sec not verified within last 5 seconds
3	1PPS Pulse from GPS satellite receiver is OK	1 PPS pulse from GPS satellite receiver is bad. In applications with modulated time code inputs only, this status bit will always be set.
4	GPS satellite receiver serial data being received OK	No serial data being received from GPS satellite receiver. In applications with modulated time code inputs only, this status bit will always be set.
5	GPS satellite receiver is tracking enough satellites for accurate UTC time.	GPS satellite receiver is not tracking enough satellites for accurate UTC time. In applications with modulated time code inputs only, this status bit will always be set.
6	Time code input being decoded	Time code input not decodable. In applications without modulated time code inputs, this status bit will always be set.
7	If using 1PPS, set NEXT 1PPS TIME command sequence has been performed. Used for Option -M only Waiting for "SET NEXT 1PPS TIME" command. Used for Option -M only	Waiting for "SET NEXT 1PPS TIME" command. Used for Option - M only

IRIGB Date and Time:-

The IRIGB card extracts months, days, hours, minutes, seconds, milliseconds and microseconds information from the IRIGB network message it does not however extract year information, the year information has to be entered manually using the configuration software date and time sync message. Once the year information has been set correctly it will remain correct indefinitely so long as the 9000TS is powered. When the 9000TS is power down the year information will remain correct for six months, after which the date and time information would have to be manually set once again.

IRIGB Sync:-

Until the IRIGB card achieves an accurate time sync with the incoming IRIGB network the 9000TS clock will free run using the IRIGB card clock as its reference, once an accurate time sync to the IRIGB signal is established the 9000TS clock is effectively tied to the IRIGB network time. There are three ways to check for IRIGB network synchronisation:-

1. Status LED as described in previous section.
2. Select a common relay to follow "GPS Lock Fault" – relay will change state when sync is lost.
3. Indicum – Event type 162 indicates sync ok and event type 163 indicates sync lost.

Note: IRIGB sync loss will be reported after a period of approx 250 seconds. IRIGB sync re-established will be reported in approx 30 seconds.

SECTION 22 – SPARE PARTS LIST

PART NO	DESCRIPTION
P925TS-RK	Base Rack
P925TS-RK-ETN	Expansion Rack
P925TS-I	16 Channel Input Card
P925TS-O	16 Channel Output Card
P925TS-R	16 Channel Relay Card
P925TS-X	Interface Card
P925TS-BL	Blanking Plate
P925TS-CABLE-1	1 metre Ribbon Cable for interconnecting Chassis (standard length)
FU-1A-003	1A Signal Supply Fuse
FU-5A-005	5A Logic Fuse

SECTION 23 – SERVICING

Module Removal

9000TS Systems can be constructed using a combination of 16 channel input, output and relay cards as required.

P925TS-I Input Cards

Each card type is universal in application and can therefore be exchanged with any other card in the system.

However, before a card is relocated the following points should be considered.

- **Card address setting:** - Each card within the rack has been factory set to a unique address to allow inter-card and system wide communication – therefore it is important to note the address setting of any card before any changes are made. Full details of address setting are provided within this manual
- **Automatic configuration:** - The 9000TS System is designed to allow hot-swapping of cards and the interface card will automatically detect the introduction of a new card and the configuration will be automatically updated to the same settings as the original card.
- **Signal supply voltage level:** - Standard systems use +24VDC supplied via the alarm rack for use as a signal supply voltage. In certain applications higher voltage inputs may be required and therefore each channel is equipped with a 3 way header and 2 way shorting bar to allow the user to select either the standard 24VAC/DC setting or the optional 125VAC/DC setting. Additional options exist for 48VAC/DC and 250VAC/DC versions.

P925TS-O Output Cards

Each card type is universal in application and can therefore be exchanged with any other card in the system.

However, before a card is relocated the following points should be considered.

- **Card address setting:** - Each card within the rack has been factory set to a unique address to allow inter-card and system wide communication – therefore it is important to note the address setting of any card before any changes are made. Full details of address setting are provided within this manual

P925TS-R Relay Cards

Each card type is universal in application and can therefore be exchanged with any other card in the system.

However, before a card is relocated the following points should be considered.

- **Card address setting:** - Each card within the rack has been factory set to a unique address to allow inter-card and system wide communication – therefore it is important to note the address setting of any card before any changes are made. Full details of address setting are provided within this manual
- **Coil state:** - Each relay can be set to operate from a normally energised or normally de-energised condition – please ensure any new card is set to the same configuration.
- **Contact state:-** The contact state of each relay can be set to normally open or normally closed

P925TS-X Interface Cards

- **Card switch settings:** - In the unlikely event of failure of the interface card the user would need to check that the new card has all of the jumpers set to same position as the original card.
- **Software configuration:** - Once the card has been installed the user would need to down-load the original configuration from a suitable PC.

SAFETY

The P925TS-X Interface contains a processor card which is equipped with a lithium coin-cell long life battery.

This battery should be removed by suitably qualified personnel at the end of its life.

If required the replacement model number is CR 2032 Coin cell. (3.0V lithium, 180mAH)

Please dispose of the battery in accordance with local laws and we note it should **not** be placed with normal waste.



BATTERY DISPOSAL

SECTION 24 – TROUBLE SHOOTING GIUDE

Status Led on all cards fail to illuminate

Possible cause:-

- Interface card not started.

Solution:-

- Check that sync and status LED's on the interface card are flashing at approx 0.5 Hz, if not then restart the system and wait 3 minutes for the system to start. Check again the sync and status LED's for correct function, if the interface card has failed to started contact RTK for advice.

Status led on some input cards fail to illuminate

Possible cause:-

- Input card has address set incorrectly.

Solution:-

- Remove card and check / change address settings on 8way switch as per user instructions. Replace card and check if status Led illuminates.

Possible cause:-

- More than one input card has the same address.

Solution:-

- Remove all input cards and check / change address settings on 8way switch as per user instructions. Replace input cards one by one confirming each time the sign on address via the display LED's on the front of the input card, printer or AMS outputs. If a card signs on with the wrong address please re-check the address settings, if they are found to be correct then contact RTK for advice and possible replacement card.

Possible cause:-

- New card does not fit within defined system structure. E.g. the system structure is set for 10 input cards and the user has fitted 11 to the system.
Note: An input card cannot sign on if it is not defined within the SYS9000 structure.

Solution:-

- If the card to be added is of the same type as existing cards in the system then it is possible to use the "add and remove" card feature in the configuration software to add an additional card. It is important to note that this feature is not available on all versions of the configuration software, if you do not appear to have this feature please contact RTK for advice and possible configuration software update.
If the card to be added to the system is a new card type e.g. your system consists of only input cards and you wish to add output cards you must contact RTK for advice.

Possible cause:-

- Card is faulty.

Solution:-

- If you have tried all of the above solutions without success then contact RTK for advice and possible card replacement.

Status led on some output cards fail to illuminate

Possible cause:-

- Output card has address set incorrectly.

Solution:-

- Remove card and check / change address settings on 8way switch as per user instructions. Replace card and check if status Led illuminates.

Possible cause:-

- More than one output card has the same address.

Solution:-

- Remove all output cards and check / change address settings on 8way switch as per user instructions. Replace output cards one by one confirming each time the sign on address via the display LED's on the front of the output card, printer or AMS outputs. If a card signs on with the wrong address please re-check the address settings, if they are found to be correct then contact RTK for advice and possible replacement card.

Possible cause:-

- New card does not fit within defined system structure. E.g. the system structure is set for 10 output cards and the user has fitted 11 to the system.

Note: An output card cannot sign on if it is not defined within the SYS9000 structure.

Solution:-

- If the card to be added is of the same type as existing cards in the system then it is possible to use the "add and remove" card feature in the configuration software to add an additional card. It is important to note that this feature is not available on all versions of the configuration software, if you do not appear to have this feature please contact RTK for advice and possible configuration software update.
If the card to be added to the system is a new card type e.g. your system consists of input and output cards and you wish to add relay cards you must contact RTK for advice.

Possible cause:-

- Card is faulty.

Solutions:-

If you have tried all of the above solutions without success then contact RTK for advice and possible card replacement.

Status led on some relay cards fail to illuminate*Possible cause:-*

- Relay card has address set incorrectly.

Solution:-

- Remove card and check / change address settings on 8way switch as per user instructions. Replace card and check if status Led illuminates.

Possible cause:-

- Input and Relay card not linked. The relay card cannot sign on without being linked to an input card this is done via switches on the rack mother board.

Solution:-

- Check mother board switch settings between complementary input and relay cards, refer to section "INTER CARD COMMUNICATIONS" for information.

Possible cause:-

- More than one relay card has the same address.

Solution:-

- Remove all relay cards and check / change address settings on 8way switch as per user instructions. Replace relay cards one by one confirming each time the sign on address via the display LED's on the front of the relay card, printer or AMS relays. If a card signs on with the wrong address please re-check the address settings, if they are found to be correct then contact RTK for advice and possible replacement card.

Possible cause:-

- New card does not fit within defined system structure. E.g. the system structure is set for 10 relay cards and the user has fitted 11 to the system.

Note: A relay card cannot sign on if it is not defined within the SYS9000 structure.

Solution:-

- If the card to be added is of the same type as existing cards in the system then it is possible to use the “add and remove” card feature in the configuration software to add an additional card. It is important to note that this feature is not available on all versions of the configuration software, if you do not appear to have this feature please contact RTK for advice and possible configuration software update.

If the card to be added to the system is a new card type e.g. your system consists of input and relay cards and you wish to add output cards you must contact RTK for advice.

Possible cause:-

- Card is faulty.

Solution:-

- If you have tried all of the above solutions without success then contact RTK for advice and possible card replacement.

Events lost during power down

Possible cause:-

- Interface card battery link disabled position or battery needs replacing.

Solution:-

Remove the interface card. At the rear of the interface card you will see a circular button battery cell, next to this battery cell is a link this should be in the Battery enabled position. If the link is correct then the battery needs replacing. Battery model number is CR 2032 button cell.

- Link in position closest to Ethernet connector – Battery enabled
- Link in position furthest from Ethernet connector – Battery disabled



Battery cell

Battery link

Ethernet connector

Port 2 configuration (programme) does not work

Possible cause:-

- Port set to dual functionality.

Solution:-

- Press button 2 on the front of the interface card to toggle between port functionality. When port 2 programme function is selected it will remain in the programming mode until button 2 is pressed again or port 2 has been idle for one minute or more.

Input card channel does not respond to local input change

Possible cause:-

- Input channel remote mapping is selected.

Solution:-

- De-select remote mapping by following instruction in the configuration manual.

Output card channel does not respond to local input change

Possible cause:-

- Output channel remote mapping is selected.

Solution:-

- De-select remote mapping by following instruction in the configuration manual.

Possible cause:-

- Input and Output card not linked. The output card receives local channel data via a local serial network linking complementary input and output cards. The serial network link is selected via switches on the rack mother board.

Solution:-

- Check mother board switch settings between complementary input and output cards. Refer to section "INTER CARD COMMUNICATIONS" for information.

Relay card channel does not respond to input change

Possible cause:-

- Input and Relay card not linked. The relay card receives local channel data via a local serial network linking complementary input and relay cards. The serial network link is selected via switches on the rack mother board.

Solution:-

- Check mother board switch settings between complementary input and relay cards. Refer to section "INTER CARD COMMUNICATIONS" for information.

Input card channel does not respond to remote input change

Possible cause:-

- Input channel remote mapping is not selected.

Solution:-

- Select remote mapping by following instruction in the configuration manual.

Possible cause:-

- Input channel is incorrectly port mapped.

Solution:-

- Refer to configuration manual for information on port mapping.

Output card channel does not respond to remote input change

Possible cause:-

- Output channel remote mapping is not selected.

Solution:-

- Select remote mapping by following instruction in the configuration manual.

Possible cause:-

- Output channel is incorrectly I/O mapped.

Solution:-

- Refer to configuration manual for information on I/O mapping.

Input Card fails to sign on

Refer to trouble shooting heading – “Status Led on some input cards fail to illuminate”

Output Card fails to sign on

Refer to trouble shooting heading – “Status Led on some output cards fail to illuminate”

Relay Card fails to sign on

Refer to trouble shooting heading – “Status Led on some relay cards fail to illuminate”

Sustained watchdog relay fault

Possible cause:-

- Card not signed on.

Solution:-

- Refer to trouble shooting heading – “Status Led on some input cards fail to illuminate”
- Refer to trouble shooting heading – “Status Led on some output cards fail to illuminate”
- Refer to trouble shooting heading – “Status Led on some relay cards fail to illuminate”

Possible cause:-

- 9000TS system structure is modified when a watchdog error existed. Watchdog faults, events, status block entries cannot be cleared in the normal way if the card that created the record no longer exists in the system structure.

Solution:-

- Restore the original 9000TS system structure using the configuration software or remove and refit the interface card battery; this will clear all records including outstanding events.

Intermittent watchdog relay fault

Possible cause:-

- Input card has address set incorrectly.

Solution:-

- Remove card and check / change address settings on 8way switch as per user instructions. Replace card and check if status Led illuminates.

Possible cause:-

- Output card has address set incorrectly.

Solution:-

- Remove card and check / change address settings on 8way switch as per user instructions. Replace card and check if status Led illuminates.

Possible cause:-

- Input/Output/Relay card is faulty.

Solution:-

- If you have tried all of the above solutions without success then contact RTK for advice and possible card replacement.

Sustained printer watchdog fault

Refer to trouble shooting heading – “Sustained watchdog relay fault”

Intermittent printer watchdog fault

Refer to trouble shooting heading – “Intermittent watchdog relay fault”

Sustained AMS watchdog fault

Refer to trouble shooting heading – “Sustained watchdog relay fault”

Intermittent AMS watchdog fault

Refer to trouble shooting heading – “Intermittent watchdog relay fault”

Unable to clear status event

Possible cause:-

- 9000TS system structure has been modified causing a status value to be allocated against a card which no longer exists in the system structure. A default status value cannot be cleared in the normal way if the card that created the record no longer exists in the system structure.

Solution:-

- Restore the original 9000TS system structure using the configuration software or remove and refit the interface card battery; this will clear all records including outstanding events.

Interface card status led not illuminated / flashing

Possible cause:-

- System initialising.

Solution:-

- Please wait up to 3 minutes for system to start.

Possible cause:-

- Power fault.

Solution:-

- Check all power supply levels and connections.

Possible cause:-

- Interface card fault.

Solution:-

- If you have tried all of the above solutions without success then contact RTK for advice and possible card replacement.

Interface card sync led not illuminated / flashing

Possible cause:-

- System initialising.

Solution:-

- Please wait up to 3 minutes for system to start.

Possible cause:-

- Power fault.

Solution:-

- Check all power supply levels and connections.

Possible cause:-

- External sync fault.

Solution:-

- Check external sync connections on the rear of the rack.

Possible cause:-

- Interface card fault.

Solution:-

- If you have tried all of the above solutions without success then contact RTK for advice and possible card replacement.

Card functions incorrectly

Possible cause:-

- Card configuration downloaded to interface card in the system but changes have not yet been distributed throughout the system.

Solution:-

- Please wait up to 3 minutes for changes to be effected.

Unable to silence audible / horn on input card only system

Possible cause:-

- Silence Pushbutton input not enabled.

Solution:-

- Enable Silence Pushbutton global setting. Refer to configuration manual for more details.

Possible cause:-

- Input cards not linked.

Solution:-

- Silence function in an input card only system requires all input cards to be linked together via the local network. Check that mother board switch settings between all input cards are enabled. Refer to section "INTER CARD COMMUNICATIONS" for information.

Silence audible / horn on input card only system unresponsive

Possible cause:-

- Silence pushbutton uses only input channel.

Solution:-

- An input card only system using an input channel only for silence function can take several seconds to silence the horn / audible. This delay can be removed if an additional silence pushbutton contact is added, this extra contact should be normally open and connected to the terminals marked M/S +ve and M/S -ve on the rear of the first rack.

SECTION 25 – CONTACT

RTK Instruments Limited
St James Business Park
Knaresborough
North Yorkshire
HG5 8PJ

Telephone / Fax Number List

Telephone: 0044 (0) 1423 580500
Fax: 0044 (0) 1423 580501
www.rtkinstruments.com

Procedures for Factory Repair and Return Warranty

Please refer to the RMA Form on the following page which we request is copied to allow the user to complete the details to request a Returns Materials Authorisation Number.

Once the form has been received by RTK an RMA number will be advised and we request that this number is used on any corresponding paperwork / packing lists.

RTK kindly request that all goods are adequately packed and note that we cannot be held responsible for any transit damage caused by inadequate packing.

RMA FORM

RTK Instruments Limited
St James Business Park,
Knaresborough, North Yorkshire,
England. HG5 8PJ

Telephone: +44 (0)1423 580500
Facsimile: +44 (0)1423 580501
Web: www.rtkinstruments.com
Email: enquiry@rtkinstruments.com



Advance Replacement Tracking No RMA****

To request advance replacements for parts that have been reported faulty during the warranty period please complete the details below.

Customer	
Address	
Contact	
Telephone No	
Fax No	

Items to be Returned

Qty	Part No.	Serial No.	Reported Fault

Note: If the replacement item is different this will be shown on the related sales Order

RTK Commitment

As part of the ongoing service and support to our customers we agree to supply Advance Replacements on the basis that our instruments are used as a critical part of plant control and instrumentation and also in many safety critical applications.

Agreement from the client

As part of the agreement to supply parts as Advance Replacements we also need certain limited commitments from the customer as follows: -

1. The original parts shall be returned, within 30 days of despatch of the advance replacements, to allow our QA / Test department to investigate the reason of failure. If the goods are not received within this period then the user agrees to pay for the advance replacements (and related carriage) in full.
2. If the failure is found to be caused by RTK workmanship or component failure there will be no charge incurred for the materials or the ongoing carriage.
3. If the returned goods are found to have been damaged by incorrect operation or misuse a charge will be incurred to cover the costs of repair, recalibration and carriage costs.
4. If the returned goods are found to have no faults the user agrees to pay a handling, inspection, re-test and carriage charge.

Customer Authorisation Signature:-

Name:-

FAX Back to +44 (0)1423 580501